

Collaborative Robot
TM-S Series

OMRON

OMRON TM Collaborative Robot S Series



The OMRON TM S Series of collaborative robots includes advanced hardware options and expanded safety features and certifications.

OMRON TM Collaborative Robot - S Series

The OMRON TM Collaborative Robot - S Series includes a wide variety of models with reach and payload suitable for different applications, including the DC power mobile robot compatible, EtherNet/IP, and PROFINET versions.

With 31 Safety Features, the OMRON S Series meets ISO 13849-1, Cat.3, PL D and ISO 10218 -1 Safety Standards, certified by TUV Nord. The new OMRON S Series also comes with the UL/CSA certifications from SGS.



OMRON TM5S
900MM REACH



OMRON TM7S
700MM REACH



OMRON TM12S
1200MM REACH



OMRON TM14S
1100MM REACH



OMRON TM25S
1100MM REACH

Target Industries

OMRON TM Collaborative Robots are designed for a wide variety of applications in a number of industries.

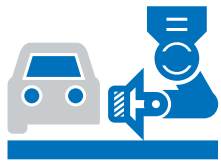

ENVIRONMENTAL MOBILITY

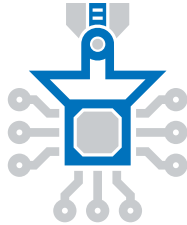

DIGITAL DEVICES

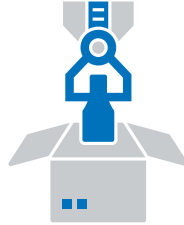

FOOD & COMMODITIES



MEDICAL



LOGISTICS

Target Applications



VISUAL INSPECTION

OMRON S Series comes standard with built-in high resolution camera and can conduct visual inspection on parts, part numbers and labels for greater accuracy and higher quality.



ASSEMBLY

Our cobots can improve throughput and consistency of repetitive or complex assembly tasks including part joining, insertion, tool changing, and working alongside people.



MOBILE MANIPULATION:

Mounting an OMRON TM cobot onto an OMRON LD or MD mobile robot automates not only transportation of goods but also complex picking operations.



PALLETIZING

Palletizing operation are faster than ever with increased joint speed and range. With a wide range of available payloads and reach, you can find the robot that is right for your application.



MACHINE TENDING

Avoid repetitive and dangerous work by letting a cobot tend CNC machines, injection molding machines, stamping and punch pressers, grinding, and cutting machines.



PACKAGING

Our cobots can pick up, inspect, and sort products directly from a moving conveyor belt.



PICK AND PLACE

Our cobots are highly flexible and have a small footprint, so they can easily be moved from one station to another for high-mix / low-volume pick-and-place applications.



MORE

The wide range of payload and reach options, combined with high precision, high resolution camera, and advanced safety features makes OMRON TM S Series cobot the ideal choice for nearly any application.

Ease of Use

Improved hand guidance and next-generation teach pendant make programming the OMRON S Series easier than ever.

Advanced hand guiding experience:

Applications can be programmed using the built-in hand guidance function. Simply move the head to the desired position, and with the click of a button, the position is taught.



Figure 25: Robot Stick (front)

The new Robot Stick is designed to convert an **OMRON TM Screen** to a teaching pendant.

- Operate, control, and program the cobot using a touch screen
- No wiring or additional chip installation only by OMRON
- OMRON TM Pen is available



Built-in Vision System

The integrated vision system is the biggest advantage of OMRON TM cobots. It is designed for industrial grade pattern recognition, object positioning, and feature identification. Users can set up vision tasks for immediate deployment without going through complex steps if integrating external cameras or lighting equipment.

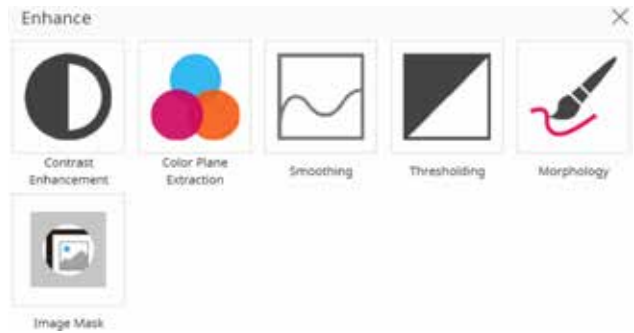
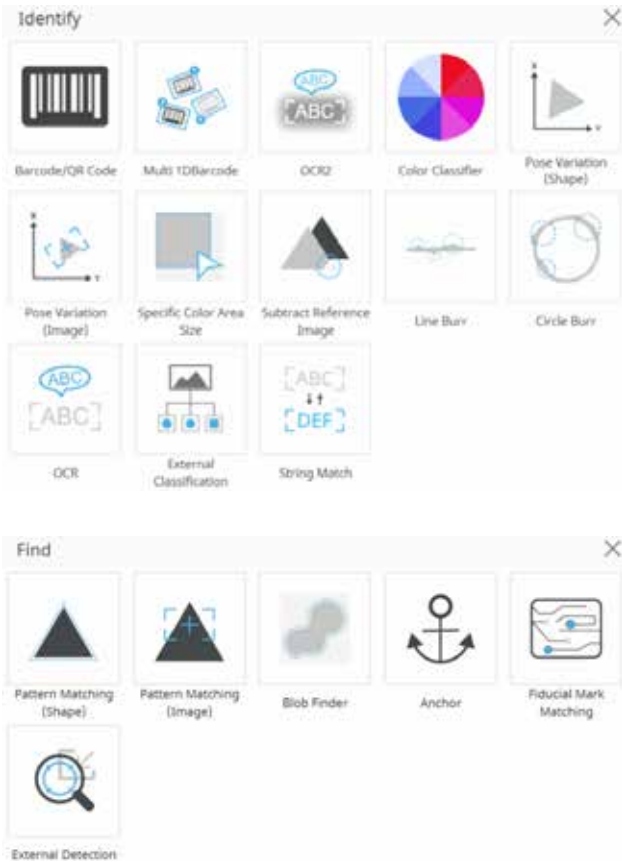

Pattern Machine Template

Vision Calibration

TMvision Workflow

TMflow

OMRON's highly versatile programming software for collaborative robots is more capable and easier to use than ever before.

Programming Improvements

Project Stop and Error Stop Handling Procedures

- Users can create special subflow logic to define the steps the robot takes after a project or error stop.

Tool Setting Improvements

- Tool Settings option added to the project page for easier access so users no longer need to navigate away from the project page to change Tool Settings.

Operational Improvements Behavior

Improvements when Passing Through Singularity

- The new Singularity Handling feature improves the robot's behavior by purposefully slowing down at the point of singularity and avoiding joint speed errors and sudden stops. This feature can be enabled for Point and Move nodes that use Line motions. Motion blending will be disabled when Singularity Handling is enabled.

Redefine Payload Settings in Motion Nodes

- New Payload Settings UI in motion nodes make it easier for users to configure the robot picking up or releasing a workpiece. For applications with unknown or widely varying payloads, the robot can now use an external force and torque sensor to automatically calculate and compensate for the payload mass.

Pattern-Matching UI Improvement

- Users can choose from three pattern-matching algorithms in TMvision Find tasks for more reliable results. The object detection score is more intuitive, represented as a single numerical value.



Tool Setting Improvements

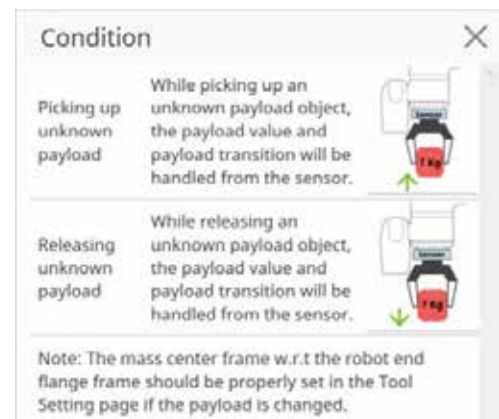

Payload Settings

TMSimulator

The new OMRON TMSimulator lets users test and verify proper operation by developing, editing and running programs offline. By building programs offline, users can develop new processes without having to take a robot out of production.

The onscreen display includes a virtual robot stick so users can control the robot just as they would control a physical robot. In addition to the standard robot control buttons, the virtual robot stick has buttons for RESET, Point, and Gripper.

The TMSimulator can test Listen Node and Network Node communications. Modbus, Ethernet Slave, and serial configurations can also be tested.

The TMSimulator also has options for DI and AI Signal Control Box Input Control.

This version of TMSimulator works with the following S Series Model robots (HW5.0):

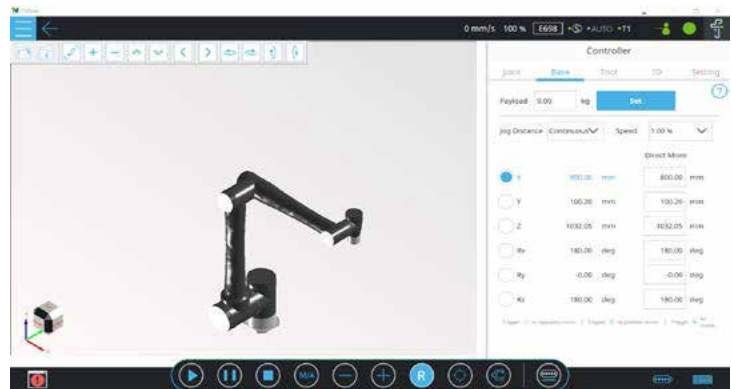

- TM5S-X
- TM7S-X
- TM12S-X
- TM14S-X
- TM25S-X

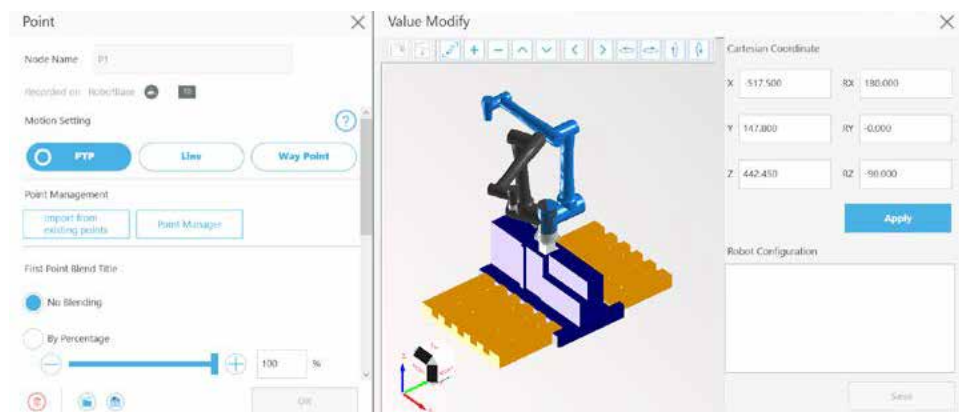

Safety

Newly added safety functions provides a wide variety of safety devices/switch configurations without the need for an additional safety controller.

Safety Features

- 31 Safety features in total
- 12 Newly added safety features

Robot Stick E-Stop

User Connected E-Stop Input

Encoder Standstill Output

User Connected External Safeguard Input

Additional Joint Torque Monitoring

Joint Position Limit

Joint Speed Limit

Speed Limit

Additional Force Limit

User Connected External Safeguard Input for Human-machine Safety Settings

Robot E-Stop Output

User Connected External Safeguard Output

Robot Human-Machine Safety Setting Output

Robot Recovery Mode Output

Robot Moving Output

User Connected Enabling Switch Input

User Connected E-Stop Input without Robot E-Stop Output

Cartesian Limit A

Cartesian Limit B

NEW Robot Stick Enabling Switch

NEW Reset Output

NEW Robot Stick Reset

NEW Enabling Switch on end-module

NEW User Connected External Bumping Sensor Input

NEW End-Point Reduced Speed Limit

NEW User Connected MODE Switch Input

NEW User Connected Reset Input

NEW User Connected Soft Axis Setting Switch Input

NEW Enabling Switch Output

NEW MODE Switch Output

NEW Safe Home Output

Certifications:

- ISO 13849-1, Cat.3, PL d
- ISO 10218-1:2011
- UL & CSA Safety Certification

Protections:

- IP54 rating for Robot Arm, AC control box, Robot Stick and TM screen.
- ISO Class 3 for the Cleanroom
- Enhance oil resistant covers for joints

Anatomy of OMRON TM S Series Cobot

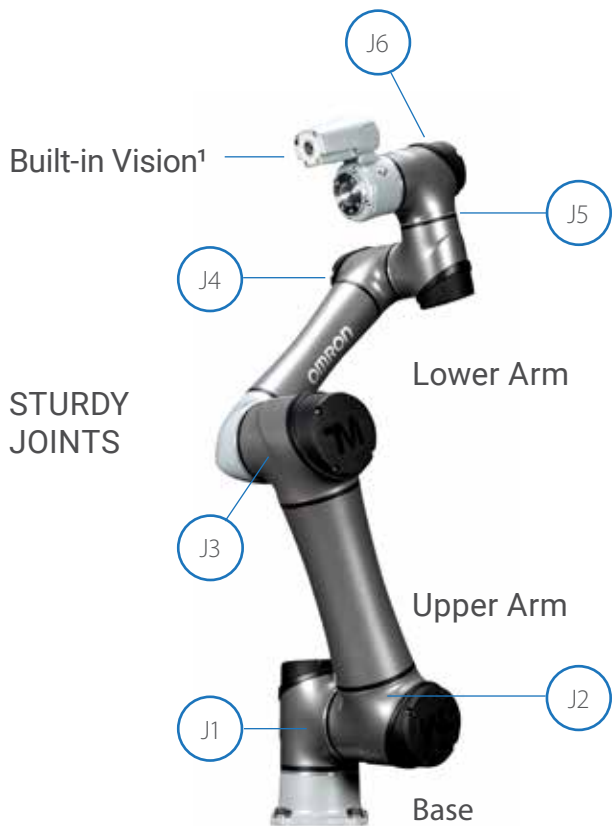

STURDY JOINTS

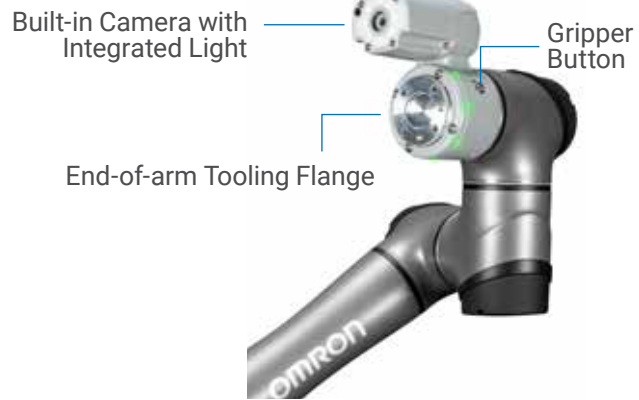
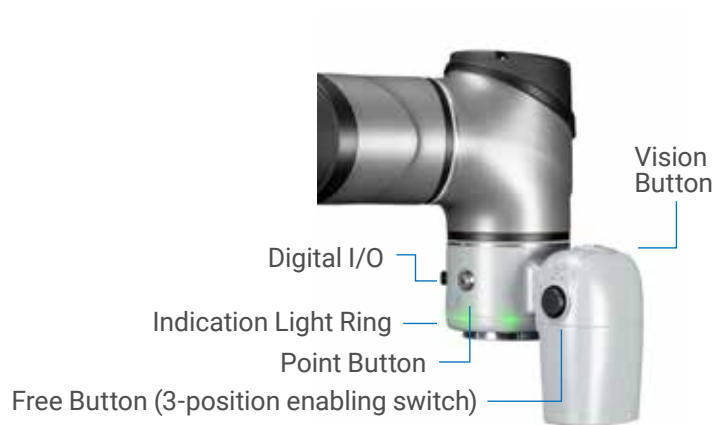

1. Not available for non-camera version

Maximum Payload

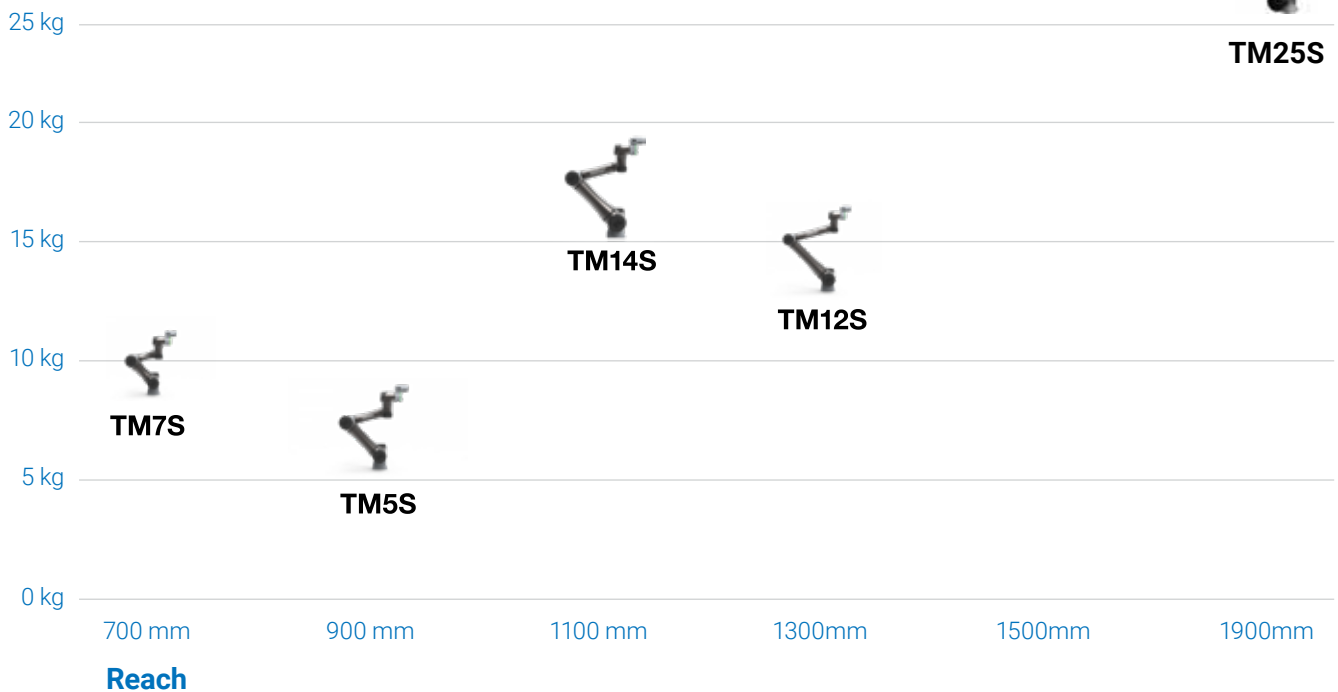

OMRON S Series Cobots' Main Advantage

	Payload	A wide range of payload options from 5 kg up to 25 kg
	Joint Range	360° freedom for J1, J2, J3, J5 and J6
	Motor Speed	The joint speed J6 increased from 225 °/s to 450 °/s; Faster or equivalent J1~J5
	Repeatability	Maximum 70% improvement of repeatability to 0.03 mm*
	Ingress Protection Level	IP54: Robot Arm, AC control box, Robot Stick, TM Teach Pendant
	Anti Cutting Oil Corrosion	Enhanced joint covers
	Safety	31 Safety features; PLD Cat.3, TÜV Nord certified CE SGS certified UL/CSA



Cobots vs. Industrial Robots

OMRON TM Collaborative Robots change the way in which traditional factories work. Physical cages are no longer needed. Designed for high-mix, low-volume production at a speed comparable to human workers, OMRON cobots can work in harmony with humans.

Industrial Robot

- Requires cage
- Multiple sensors required for safety

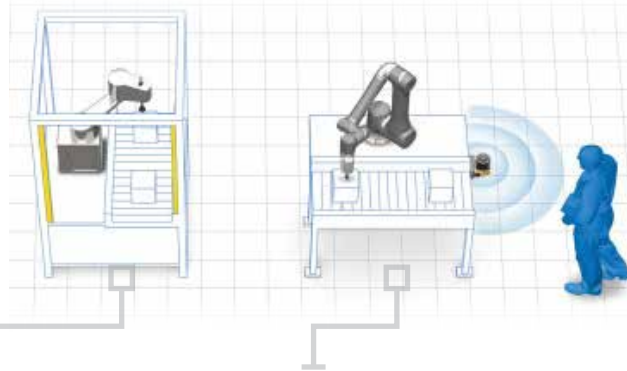

Collaborative Robot

- Smaller footprint
- No physical barriers

Traditional Industrial Robots

OMRON Cobots

	Traditional Industrial Robots	OMRON Cobots
Safety	Needs a physical barrier, such as a fence or cage, to ensure safety.	Designed to be inherently safe but may need safety sensors (e.g. OMRON safety laser scanner) based on risk assessment. Typically does not need physical barrier if working in collaborative mode. Simple safety software with easy-to-use graphical user interface.
Workspace	Separated from human workspace.	Can be shared with people.
Footprint	Large	Small
Flexibility	No. Fixed to one location and works on dedicated task.	Yes. Can be moved between locations during the day to work on different tasks. Built-in camera and Landmark positioning enable quick relocation.
Programming	Difficult. Requires skill and training.	Easy. Can be done with minimal training.
Setup	Requires advanced skills and is time-consuming.	Quick and easy.
Application	Fit for mass production at high speeds.	Fit for high-mix, low-volume production at a speed comparable to human workers. Can be used at high speeds with safety measures.
Cycle Time (Pick & Place)	Down to seconds	Over 5 seconds
Speed of Process (Path)	Fast	Slow
Repeatability	+/- 0.02 mm	TM5S, TM7S, TM12S, and TM14S: +/- 0.03 mm TM25S: +/- 0.05 mm
Environment	IP requirements above IP54	IP54 for robot arm, AC control box, Robot Stick, and TM Screen
Process Complexity	Can be complex	Should be simple

Plug & Play

OMRON has partnered with a select number of companies to offer a wide variety of peripherals that quickly and easily integrate with our cobots, allowing for a faster deployment and return on investment. They are collectively referred to as Plug & Play devices and software, designed to serve a broad range of customer applications and meet the highest testing standards of OMRON.



Plug & Play Kits

All products come as a ready-to-use kit for easy installation



S Series Specifications

		TM5S	TM7S	TM12S	TM14S	TM25S
Weight with camera		23.9 kg	22.9 kg	23.5 kg	22.6 kg	81.6 kg
Weight without camera		23.6 kg	22.6 kg	33 kg	32.7 kg	81.3 kg
Maximum payload		5 kg	7 kg	12 kg	14 kg	25 kg
Reach		900 mm	700 mm	1300 mm	1100 mm	1902 mm
Joint ranges	J1, J2, J4, J5, J6	+/- 360°				
	J3	+/- 158°	+/- 152°	+/- 162°	+/- 159°	+/- 166°
Joint speed	J1, J2	180°/s		120°/s		100°/s
	J3	180°/s		180°/s		130°/s
	J4	225°/s		225°/s		195°/s
	J5	225°/s		225°/s		210°/s
	J6	450°/s		450°/s		225°/s
Average speed¹		1.4 m/s	1.1 m/s	1.3 m/s	1.1 m/s	2.1 m/s
Repeatability		+/- 0.03 mm	+/- 0.03 mm	+/- 0.03 mm	+/- 0.03 mm	+/- 0.05 mm
Degrees of freedom		6 rotating joints				
I/O ports	Control Box	Digital In: 16 / Digital Out: 16 Analog In: 2 / Analog Out: 2				
	Tool Con.	Digital In: 3 / Digital Out: 3				
I/O power supply		24 V 2.0 A for control box and 24 V 1.0 A for tool				24 V 2.0 A for control box and 24 V 1.5 A for tool
IP classification		IP54 for Robot Arm, AC Control Box, Robot Stick and TM Screen				
Cleanroom Class		ISO Class 3				
Operating Temperature and Humidity		0 to 50°C, 85% max. (with no condensation)				
Motor Power supply		100-240 VAC, 50-60 Hz for AC units; 24 to 60 VDC for DC units				200-240 VAC (AC) 48-60 VDC (DC)
I/O interface		2×COM, 1×HDMI, 3×LAN, 2×USB2.0, 4×USB3.0				
Communication		RS232, Ethernet, Modbus TCP/RTU (master & slave) PROFINET (optional), EtherNet/IP (optional)				
Programming environment		TMflow, flowchart based and script based				
Certification		SEMI S2 (coming soon)		SEMI S2 (optional)		
Robot vision	Eye in hand (built in)	1.2M/5M pixels, color camera (camera models only)				Auto-focused color camera with 5M resolution, working distance: 100 mm ~∞
	Eye in hand (optional)	Support Maximum 2 GigE 2D cameras				

1. Average speed was tested and calculated with robot in Performance Mode.

OMRON AUTOMATION AMERICAS HEADQUARTERS • Chicago, IL USA • 847.843.7900 • 800.556.6766 • automation.omron.com

OMRON CANADA, INC. • HEAD OFFICE

Toronto, ON, Canada • 416.286.6465 • 866.986.6766 • automation.omron.com

OMRON ELECTRONICS DE MEXICO • HEAD OFFICE

Ciudad de México • 52.55.5901.4300 • 01.800.386.6766 • mela@omron.com

OMRON ELECTRONICS DE MEXICO • SALES OFFICE

San Pedro Garza García, N.L. • 81.12.53.7392 • 01.800.386.6766 • mela@omron.com

OMRON ELECTRONICS DE MEXICO • SALES OFFICE

Eugenio Garza Sada, León, Gto • 01.800.386.6766 • mela@omron.com

OMRON ELETRÔNICA DO BRASIL LTDA • HEAD OFFICE

São Paulo, SP, Brasil • 55 11 5171-8920 • automation.omron.com

OMRON ARGENTINA • SALES OFFICE

Buenos Aires, Argentina • +54.11.4521.8630 • +54.11.4523.8483
mela@omron.com

OTHER OMRON LATIN AMERICA SALES

+54.11.4521.8630 • +54.11.4523.8483 • mela@omron.com

Authorized Distributor:

Controllers & I/O

- Machine Automation Controllers (MAC) • Motion Controllers
- Programmable Logic Controllers (PLC) • Temperature Controllers • Remote I/O

Robotics

- Industrial Robots • Mobile Robots

Operator Interfaces

- Human Machine Interface (HMI)

Motion & Drives

- Machine Automation Controllers (MAC) • Motion Controllers • Servo Systems
- Frequency Inverters

Vision, Measurement & Identification

- Vision Sensors & Systems • Measurement Sensors • Auto Identification Systems

Sensing

- Photoelectric Sensors • Fiber-Optic Sensors • Proximity Sensors
- Rotary Encoders • Ultrasonic Sensors

Safety

- Safety Light Curtains • Safety Laser Scanners • Programmable Safety Systems
- Safety Mats and Edges • Safety Door Switches • Emergency Stop Devices
- Safety Switches & Operator Controls • Safety Monitoring/Force-guided Relays

Control Components

- Power Supplies • Timers • Counters • Programmable Relays
- Digital Panel Meters • Monitoring Products

Switches & Relays

- Limit Switches • Pushbutton Switches • Electromechanical Relays
- Solid State Relays

Software

- Programming & Configuration • Runtime