

**SENTECH**

**FS-C2KU7DCL**

**FS-C4KU7DCL**

**FS-C8KU7DCL**

Color Line Scanning  
Camera Link Camera  
Product Specification

## Safety Precautions

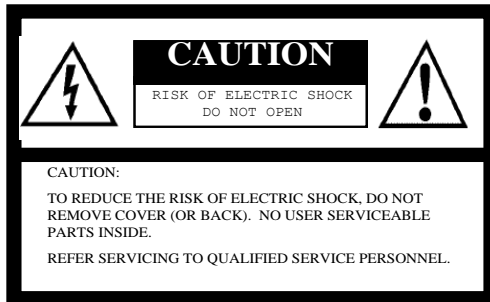

The lightning flash with arrowhead symbol, within an equilateral triangle, is intended to alert the user to the presence of uninsulated “dangerous voltage” within the product’s enclosure that may be of sufficient magnitude to constitute a risk of electric shock to persons.



The exclamation point within an equilateral triangle is intended to alert the user to the presence of important operating and maintenance (servicing) instructions in the literature accompanying the appliance.

For U.S.A.

**Warning:**

This equipment generates and uses radio frequency energy and if not installed and used properly, i.e., in strict accordance with the instruction manual, may cause harmful interference to radio communications. It has been tested and found to comply with the limits for a Class A computing device pursuant to Subpart J of Part 15 of FCC Rules, which are designed to provide reasonable protection against such interference when operated in a commercial environment.

For Canada

**Warning:**

This digital apparatus does not exceed the Class A limits for radio noise emissions from digital apparatus set out in the Radio Interference Regulations of the Canadian Department of Communications.

**WARNING:**

TO PREVENT FIRE OR SHOCK HAZARD, DO NOT EXPOSE THIS APPLIANCE TO RAIN OR MOISTURE.

## Product Precautions

- Handle the camera with care. Do not abuse the camera. Avoid striking or shaking it. Improper handling or storage could damage the camera.
- Do not pull or damage the camera cable.
- During camera use, do not wrap the unit in any material. This will cause the internal temperature of the unit to increase.
- Do not expose the camera to moisture, or do not try to operate it in wet areas.
- Do not operate the camera beyond its temperature, humidity and power source ratings.
- While the camera is not being used, keep the lens or lens cap on the camera to prevent dust or contamination from getting in the CCD or filter area and scratching or damaging this area.
- Do not keep the camera under the following conditions:
  - In wet, moist, and high humidity areas
  - Under hot direct sunlight
  - In high temperature areas
  - Near an object that releases a strong magnetic or electric field
  - Areas with strong vibrations
- Use a soft cloth to clean the camera. Use pressured air spray to clean the surface of the glass. DO not scratch the surface of the glass.

## Copyright & Disclaimer

Sensor Technologies America, Inc. (DBA Sentech America) believes the contents and specifications of its website, catalog, documentation and ads are correct; however, Sentech America provides no representation or warranty regarding such information or product(s) contained therein. It is requested that Sentech America be given appropriate acknowledgement in any subsequent use of such work by a third party.

While every effort has been made to ensure that the details contained in Sentech America's website and all documentation are correct and up-to-date, Sentech America assumes no liability, legal or otherwise for any errors in listings, specifications, part numbers, process, software or model applications. Sentech America reserves the right to change specifications, product descriptions, product quality, pricing and application at any time without prior written or oral notice. Any party using such information assumes all risk for any and all damaged caused to themselves, a third party and/or property by virtue of incorrect information and/or failure of these products. By installing and/or using a Sentech America software development kit or other similar product and/or information obtained from Sentech America's website, catalog, documentation or ads, you hereby accept and understand these stated terms and conditions.

## Contents

<b>I. General Specifications</b> .....	<b>7-8</b>
A. Electronic Specifications .....	7
B. Optical Specifications .....	8
C. Mechanical Specifications .....	8
D. Environmental Specifications .....	8
<b>II. Product Numbering</b> .....	<b>9</b>
<b>III. Connector Specifications</b> .....	<b>10-15</b>
A. FS-C4KU7DCL / FS-C4KU7DCL .....	10
B. FS-C8KU7DCL .....	11
C. Pin Assignment of the Connectors .....	12
1. Camera Link Connector (Base): MDR Receptacle (3M) .....	12
2. Camera Link Connector (Medium): MDR Receptacle (3M) .....	12
3. Power Connector: HR10A-7R-6PB (Hirose or Equivalent) .....	12
D. Bit Assignment .....	13-15
1. FS-C2KU7DCL / FS-C4KU7DCL .....	13
2. FS-C4KU7DCL / FS-C8KU7DCL .....	14-15
<b>IV. Trigger Mode and Exposure Setting</b> .....	<b>16-19</b>
A. Image Acquisition Control (Trigger and Exposure Timing) .....	16-19
<b>V. Pixel Data Output Modes</b> .....	<b>20-26</b>
A. Bayer Filter Pattern on Sensor .....	20
B. Detail of Pixel Data Output Modes .....	21-26
1. Virtual Pixel 1 MODE .....	21
2. Virtual Pixel 2 MODE .....	22
3. Raw Color Output MODE .....	23
4. Raw Direct Output MODE .....	24
5. AOI MODE .....	25
6. Raw Dual Line Output MODE .....	26
<b>VI. Video Output Formats</b> .....	<b>27-51</b>
A. Video Output Format of FS-C2KU7DCL .....	27-31
B. Video Output Format of FS-C4KU7DCL .....	32-42
C. Video Output Format of FS-C8KU7DCL .....	43-51
<b>VII. Communication Specifications</b> .....	<b>52-57</b>
A. Communication Format .....	52
B. Communication .....	52

C. Glossary .....	52
D. Notes .....	52-53
E. Command List .....	54-57
<b>VIII. Command Description .....</b>	<b>58-65</b>
A. Sync / Exposure Control .....	58
B. Sync and Exposure Mode .....	58-59
C. Exposure Time Setting (intu / intl).....	60
D. Data Rate Control (opck) .....	60
E. Digital Gain Control (gadt) .....	60
F. RGB Digital Gain (gddr, gddb, gddgr, gddgb) .....	60
G. Analog Gain Control (gbdt).....	61
H. Output Bit Setting (opbt).....	61
I. Check Communication Establishment .....	61
J. Save/ Load / Clear Camera Settings (cmsv / cmlid / cmcl).....	61
K. Viewing the “Model” and “Firm / FPGA Version” (cmmo / fivr / fpvr) .....	61
L. Viewing Active Commands (Hyper Terminal Only) (cmcm) .....	61
M. Viewing Camera Settings (Hyper Terminal Only) (cmcf) .....	62
N. Flat Field Correction (FFC) .....	62-63
O. Save Correction Value (FFC) .....	63
P. Load Correction Value (FFC) .....	63
Q. Clear FFC RAM (FFC).....	63
R. Anti-Blooming Setting (abmd) .....	63
S. User ID (usid).....	64
T. Digital Gain (gadt) .....	64
U. RGB Digital Gain (gddr, gddb, gddgr, gddgb) .....	64
V. Area of Interest.....	64
W. Size of AOI .....	65
X. Start of Pixel of AOI.....	65
<b>IX. Others .....</b>	<b>66-67</b>
A. Outline on the Camera Memories-Related CPU .....	66
1. CPU RAM.....	66
2. CPU EEPROM .....	66
3. Setting Factory Default.....	66
4. Behavior of Power .....	66
B. Outline on the Camera Memories-Related CPU.....	67

---

1. FFC RAM.....	67
2. FFC EEPROM .....	67
3. Behavior of Power .....	67
<b>X. Test Patterns .....</b>	<b>68-69</b>
A. FS-C2KU7DCL .....	68
B. FS-C4KU7DCL .....	69
<b>XI. Quantum Efficiency .....</b>	<b>70</b>
<b>XII. Dimensions .....</b>	<b>71-74</b>
A. FS-C2KU7DCL-C.....	71
B. FS-C2KU7DCL-F .....	72
C. FS-C4KU7DCL-F .....	73
D. FS-C8KU7DCL-M72 .....	74

## I. General Specifications

### A. Electronic Specifications

		FS-C2KU7DCL	FS-C4KU7DCL	FS-C8KU7DCL
Image sensor		2k CMOS image sensor DR-2X2K-7-inver- RGB(AWAIBA)	4k CMOS image sensor DR-2X4K-7-inver- RGB(AWAIBA)	8k CMOS image sensor DR-2X8K-7- RGB(AWAIBA)
Active pixels		2,048 pixels x 2lines(Bayer)	4,096 pixels x 2lines(Bayer)	8,192 pixels x 2lines(Bayer)
Pixel size		7(H) x 7(V)um (7um pitch)		
Photo array length		14.336 mm	28.672 mm	57.344 mm
data rate		85MHz x3tap(RGB) 80MHz x3tap(RGB) 50MHz x3tap(RGB)	85MHz x6tap(RGBx2) 80MHz x6tap(RGBx2) 50MHz x6tap(RGBx2) 85MHz x3tap(RGB) 80MHz x3tap(RGB) 50MHz x3tap(RGB)	85MHz x6tap(RGBx2) 80MHz x6tap(RGBx2) 50MHz x6tap(RGBx2) 85MHz x3tap(RGB) 80MHz x3tap(RGB) 50MHz x3tap(RGB)
Maximum line rate		80kHz (85MHz x3tap(RGB)) 75kHz (80MHz x3tap(RGB)) 46kHz (50MHz x3tap(RGB))	80.5kHz(85MHz x6tap(RGBx2)) 75kHz (80MHz x6tap(RGBx2)) 46kHz (50MHz x6tap(RGBx2)) 40.5kHz (85MHz x3tap(RGB)) 38.5kHz (80MHz x3tap(RGB)) 24kHz (50MHz x3tap(RGB))	40.5kHz(85MHzx6tap(RGBx2)) 38.5kHz(80MHzx6tap(RGBx2)) 24kHz (50MHzx6tap(RGBx2)) 20.5kHz (85MHz x3tap(RGB)) 19kHz (80MHz x3tap(RGB)) 12kHz (50MHz x3tap(RGB))
Video output		Camera Link Base/Medium configuration (8/10bit)	Camera Link Base/Medium/Full configuration (8/10bit)	
Power	Input voltage	+12 Vdc to +24 Vdc		
	Consumption	6.0 W(typ)	6.0 W(typ)	7.5W(typ)
Communication		RS232C via Camera Link connector		
Functions		Anti-blooming High speed exposure control External trigger control Flat Field Correction(FFC)		

## B. Optical Specifications

Product	FS-C2KU7DCL	FS-C4KU7DCL	FS-C8KU7DCL
Fill Factor	100%		
Responsivity	77DN/nj/cm <sup>2</sup>		

## C. Mechanical Specifications

Product	FS-C2KU7DCL	FS-C4KU7DCL	FS-C8KU7DCL
Dimensions	56(W) x 58(H) x 26.5(D) mm		80(W) x 100(H) x 38.1(D) mm (excluding the connector)
Lens mount	F mount, C mount	F mount	M72 mount(P=0.75mm)
Weight	about 198g		about 472g
Interface connectors	Camera Link connector (MDR) x2 Power connector (6pin connector)		
Operation temperature	0 to 40 deg. C		

## D. Environmental Specifications

Product	FS-C2KU7DCL	FS-C4KU7DCL	FS-C8KU7DCL
RoHS	RoHS compliance		
Operating temperature	0 to 40 deg. C		
Storage temperature	-30 to 65 deg. C		

## II. Product Numbering

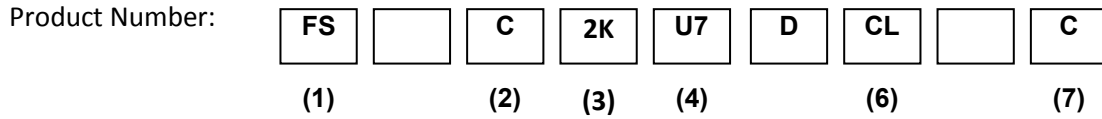

- (1). Series
- (2). Monochrome / Color
  - B: Monochrome
  - C: Color
- (3). Number of Pixels
  - 16: 16K
  - 8: 8K
  - 4: 4K
  - 2: 2K
- (4). Pixel Size
  - U14: 14 um
  - U35: 3.5um
  - U7: 7um
- (5). Line Number
  - None: 1 line (single)
  - D: 2 lines (dual)
  - Q: 4 lines (quad)
- (6). Output Type
  - CL: Camera Link
  - GE: GigE Vision
- (7). Mount Type
  - C: C Mount
  - F: F Mount
  - M72: M72 Mount

Model Number	Description
FS-C2KU7DCL-C	Color bayer 2048pixs, C-mount
FS-C2KU7DCL-F	Color bayer 2048pixs, F-mount
FS-C4KU7DCL-F	Color bayer 4096pixs, F-mount
FS-C8KU7DCL-M72	Color bayer 8192pixs, M72-mount

### III. Connector Specifications

#### A. FS-C4KU7DCL / FS-C4KU7DCL

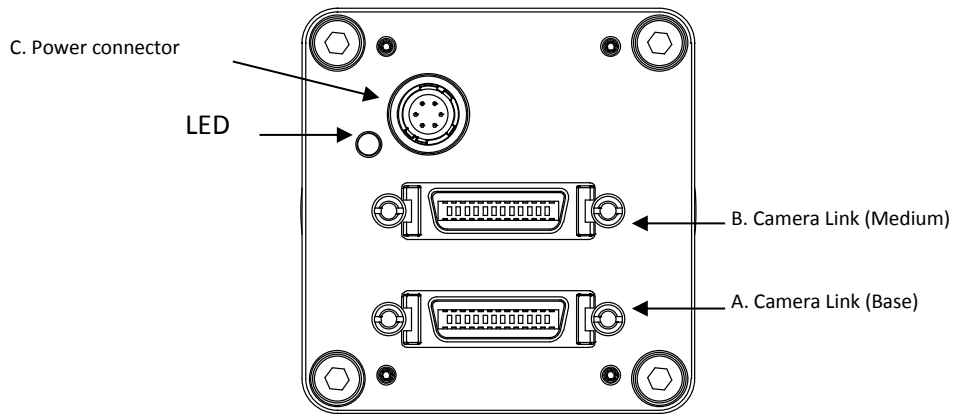

- 1. Camera Link (Base): MDR Receptacle (3M)
- 2. Camera Link (Medium): MDR Receptacle (3M)
- 3. Power Connector: HR10A-7R-6PB (Hirose or Equivalent)

This connector is for 12 Vdc power input.

The LED will display RED light when the power is on.

## B. FS-C8KU7DCL

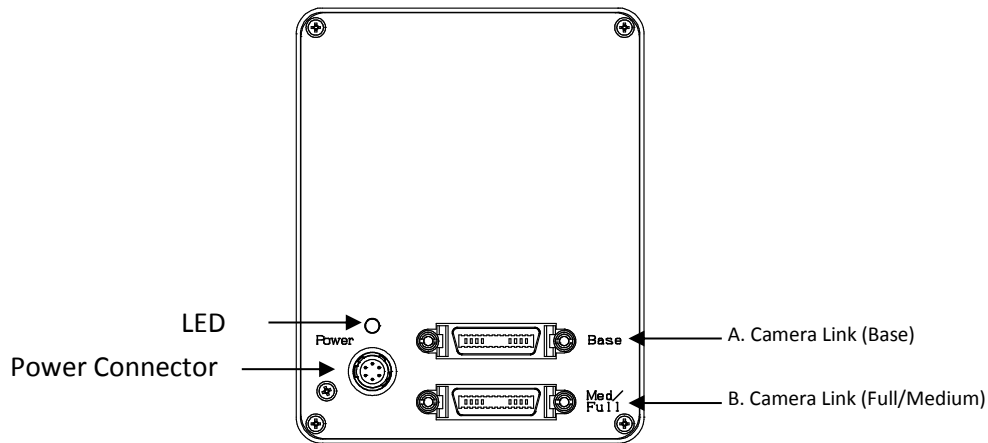

1. Camera Link Connector (Base): MDR Receptacle (3M)
2. Camera Link Connector (Full / Medium): MDR Receptacle (3M)
3. Power Connector: HR10A-7R-6PB (Hirose or Equivalent)  
This connector is for 12 Vdc power input.  
The LED indicates the camera is powered on when the light it RED.

## C. Pin Assignment of the Connectors

### 1. Camera Link Connector (Base): MDR Receptacle (3M)

Pin No.	Signal name	Pin No.	Signal name
1	GND	14	GND
2	X0-	15	X0+
3	X1-	16	X1+
4	X2-	17	X2+
5	Xclk-	18	Xclk+
6	X3-	19	X3+
7	SerTC+	20	SerTC-
8	SerTFG-	21	SerTFG+
9	CC1- (for the external sync signal input)	22	CC1+ (for the external sync signal input)
10	CC2+	23	CC2-
11	CC3-	24	CC3+
12	CC4+	25	CC4-
13	GND	26	GND

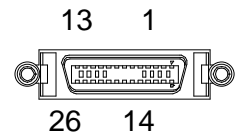

### 2. Camera Link Connector (Medium): MDR Receptacle (3M)

Pin No.	Signal name	Pin No.	Signal name
1	GND	14	GND
2	Y0-	15	Y0+
3	Y1-	16	Y1+
4	Y2-	17	Y2+
5	Yclk-	18	Yclk+
6	Y3-	19	Y3+
7	100 Ohm terminated	20	100 Ohm terminated
8	Z0-	21	Z0+
9	Z1-	22	Z1+
10	Z2-	23	Z2+
11	Zclk-	24	Zclk+
12	Z3-	25	Z3+
13	GND	26	GND

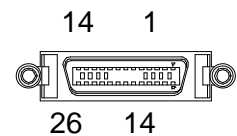

signal name	I/O	explanation
CC1	I	Ext TRG. Refer to section 5.
CC2	-	Spare
CC3	-	Spare
CC4	-	Spare
SerTC	I	Serial communication from the frame grabber.
SerTFG	O	Serial communication to the frame grabber.

### 3. Power Connector: HR10A-7R-6PB (Hirose or equivalent)

Pin No.	Signal name	IN/OUT	Voltage
1	+12 V	IN	+12 V
2	+12 V	IN	+12 V
3	+12 V	IN	+12 V
4	GND		
5	GND		
6	GND		

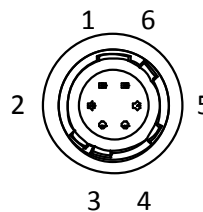

## D. Bit Assignment

### 1. FS-C2KU7DCL / FS-C4KU7DCL

8 bit x 3 tap

Base connector			
Port/bit	8-bit x 2taps	Port/bit	8-bit x 2taps
Port A0	A0	Port C0	C0
Port A1	A1	Port C1	C1
Port A2	A2	Port C2	C2
Port A3	A3	Port C3	C3
Port A4	A4	Port C4	C4
Port A5	A5	Port C5	C5
Port A6	A6	Port C6	C6
Port A7	A7	Port C7	C7
Port B0	B0		
Port B1	B1		
Port B2	B2		
Port B3	B3		
Port B4	B4		
Port B5	B5		
Port B6	B6		
Port B7	B7		

10 bit x 3 tap

Base connector			
Port/bit	10-bit x 3taps	Port/bit	10-bit x 3taps
Port A0	A0	Port C0	B0
Port A1	A1	Port C1	B1
Port A2	A2	Port C2	B2
Port A3	A3	Port C3	B3
Port A4	A4	Port C4	B4
Port A5	A5	Port C5	B5
Port A6	A6	Port C6	B6
Port A7	A7	Port C7	B7
Port B0	A8		
Port B1	A9		
Port B2	nc		
Port B3	nc		
Port B4	B8		
Port B5	B9		
Port B6	nc		
Port B7	nc		

Medium connector			
Port/bit	10-bit x 3taps	Port/bit	10-bit x 4taps
Port D0	nc	Port F0	C8
Port D1	nc	Port F1	C9
Port D2	nc	Port F2	nc
Port D3	nc	Port F3	nc
Port D4	nc	Port F4	nc
Port D5	nc	Port F5	nc
Port D6	nc	Port F6	nc
Port D7	nc	Port F7	nc
Port E0	C0		
Port E1	C1		
Port E2	C2		
Port E3	C3		
Port E4	C4		
Port E5	C5		
Port E6	C6		
Port E7	C7		

Note: For the actual output data timing, please refer to the section VI-A (Video Output Format)

## 2. FS-C4KU7DCL / FS-C8KU7DCL

8 bit x 6 tap (opck=0,1,8,11,13,14,21)

Base connector			
Port/bit	8-bit x 6	Port/bit	8-bit x 6
Port A0	A0	Port C0	C0
Port A1	A1	Port C1	C1
Port A2	A2	Port C2	C2
Port A3	A3	Port C3	C3
Port A4	A4	Port C4	C4
Port A5	A5	Port C5	C5
Port A6	A6	Port C6	C6
Port A7	A7	Port C7	C7
Port B0	B0		
Port B1	B1		
Port B2	B2		
Port B3	B3		
Port B4	B4		
Port B5	B5		
Port B6	B6		
Port B7	B7		

Medium connector					
Port/bit	8-bit x 6	Port/bit	8-bit x 6	Port/bit	8-bit x 6
Port D0	D0	Port F0	F0	Port H0	nc
Port D1	D1	Port F1	F1	Port H1	nc
Port D2	D2	Port F2	F2	Port H2	nc
Port D3	D3	Port F3	F3	Port H3	nc
Port D4	D4	Port F4	F4	Port H4	nc
Port D5	D5	Port F5	F5	Port H5	nc
Port D6	D6	Port F6	F6	Port H6	nc
Port D7	D7	Port F7	F7	Port H7	nc
Port E0	E0	Port G0	nc		
Port E1	E1	Port G1	nc		
Port E2	E2	Port G2	nc		
Port E3	E3	Port G3	nc		
Port E4	E4	Port G4	nc		
Port E5	E5	Port G5	nc		
Port E6	E6	Port G6	nc		
Port E7	E7	Port G7	nc		

8 bit x 3 tap (opck=2,3,9,15,16,22)

Base connector			
Port/bit	8-bit x 2taps	Port/bit	8-bit x 2taps
Port A0	A0	Port C0	C0
Port A1	A1	Port C1	C1
Port A2	A2	Port C2	C2
Port A3	A3	Port C3	C3
Port A4	A4	Port C4	C4
Port A5	A5	Port C5	C5
Port A6	A6	Port C6	C6
Port A7	A7	Port C7	C7
Port B0	B0		
Port B1	B1		
Port B2	B2		
Port B3	B3		
Port B4	B4		
Port B5	B5		
Port B6	B6		
Port B7	B7		

10 bit x 3 tap(opck=2,3,9,15,16,22)

Base connector			
Port/bit	10-bit x 3taps	Port/bit	10-bit x 3taps
Port A0	A0	Port C0	B0
Port A1	A1	Port C1	B1
Port A2	A2	Port C2	B2
Port A3	A3	Port C3	B3
Port A4	A4	Port C4	B4
Port A5	A5	Port C5	B5
Port A6	A6	Port C6	B6
Port A7	A7	Port C7	B7
Port B0	A8		
Port B1	A9		
Port B2	nc		
Port B3	nc		
Port B4	B8		
Port B5	B9		
Port B6	nc		
Port B7	nc		

Medium connector			
Port/bit	10-bit x 3taps	Port/bit	10-bit x 4taps
Port D0	nc	Port F0	C8
Port D1	nc	Port F1	C9
Port D2	nc	Port F2	nc
Port D3	nc	Port F3	nc
Port D4	nc	Port F4	nc
Port D5	nc	Port F5	nc
Port D6	nc	Port F6	nc
Port D7	nc	Port F7	nc
Port E0	C0		
Port E1	C1		
Port E2	C2		
Port E3	C3		
Port E4	C4		
Port E5	C5		
Port E6	C6		
Port E7	C7		

Note: For the actual output data timing, please refer to the section VI-B (Video Output Format)

## IV. Trigger Mode and Exposure Setting

### Caution:

Camera does not accept any command without sync signal. When External Trigger Mode (limd=1) is used through Hyper Terminal, please sent the commands on Internal Sync mode. And send the next command after receiving OK.

### A. Image Acquisition Control (Trigger and Exposure Timing)

#### EXT\_LINE

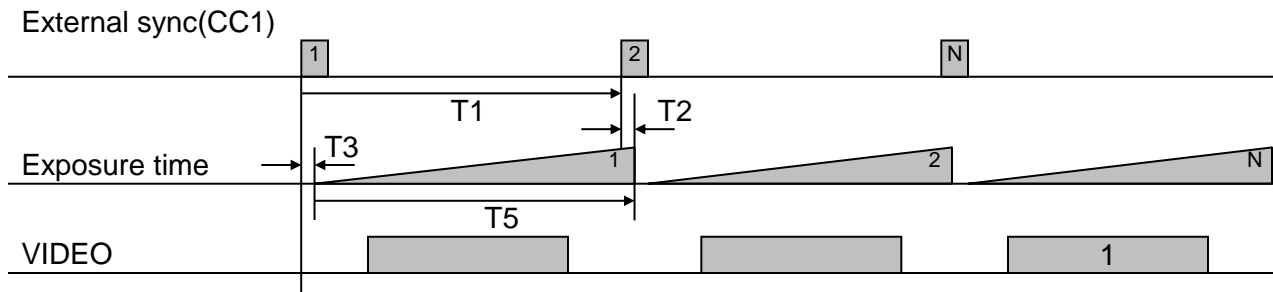

#### EXT\_FIX MODE

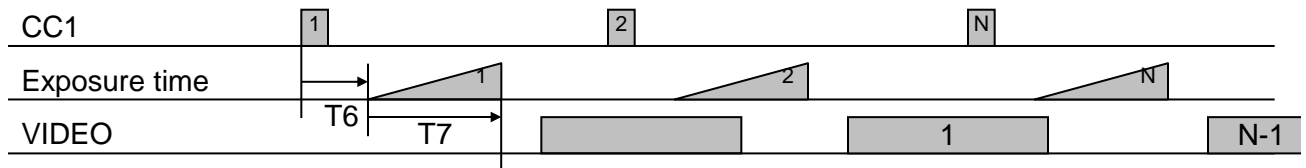

#### PULSE MODE

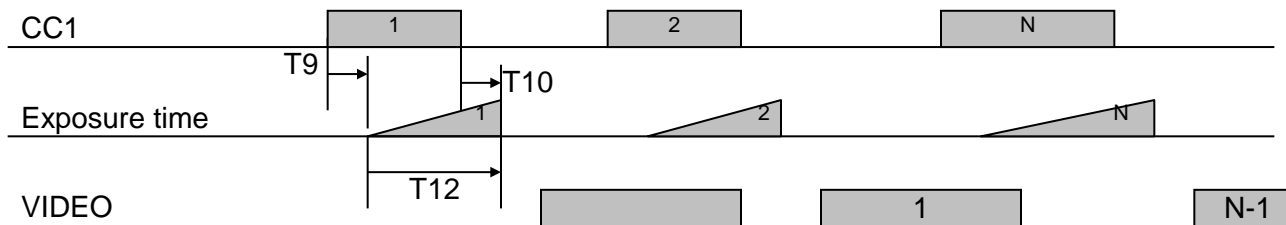

INTERNAL MODE

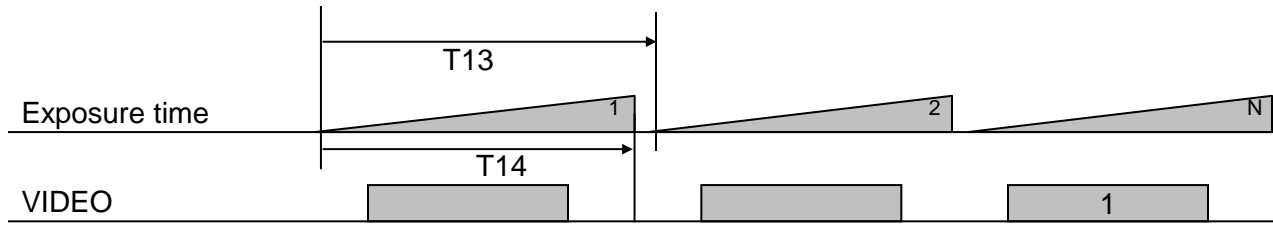

The actual time for each timing is shown in the table below.

[clk] = 11.8ns

For the detailed commands, please refer to section VII-E (Command List)

opck: Get Data Rate Mode

intu: Get the exposure time

intl: Get the exposure time

Label	Description	value
T1	Line interval	External sync : CC1 line period
T2	Sync rise to exposure end	6[clk]+1[us]
T3	Sync rise to exposure start	18[clk]+3[us]
T5	Exposure time (EXT_LINE_MODE)	T1 – 12[clk] – 2[us]
T6	CC1 rise to exposure start (EXT_FIX_MODE)	6[clk] + 2[us]
T7	Exposure time (EXT_FIX)	(intu * 256 + intl) * 0.2[us] + 2[us] min setting : intu = 0, intl = 0 Maximum Exposure Time: Line period - 3us
T9	CC1 rise to exposure start PULSE)	5[clk] + 2[us]
T10	CC1 fall to exposure end PULSE)	5 [clk] + 1[us]
T12	Exposure time (PULSE_MODE)	Pulse width of CC1 –1[us]
T13	Line interval (INTERNAL_MODE)	FS-C2KU7DCL <b>opck=0:</b> (intu * 256 + intl) * 0.2[us] + 13.2[us] <b>opck=1:</b> (intu * 256 + intl) * 0.2[us] + 21.1[us] <b>opck=8:</b> (intu * 256 + intl) * 0.2[us] + 13.2[us] <b>opck=11:</b> (intu * 256 + intl) * 0.2[us] + 12.5[us] <b>opck=13:</b> (intu * 256 + intl) * 0.2[us] + 24.5[us] <b>opck=14:</b> (intu * 256 + intl ) * 0.2[us] + 41.5[us] <b>opck=21:</b> (intu * 256 + intl ) * 0.2[us] + 26.0[us]  FS-C4KU7DCL <b>opck=0:</b> (intu * 256 + intl) * 0.2[us] + 13.2[us] <b>opck=1:</b> (intu * 256 + intl) * 0.2[us] + 21.1[us] <b>opck=2:</b> (intu * 256 + intl) * 0.2[us] + 24.5[us] <b>opck=3:</b> (intu * 256 + intl) * 0.2[us] + 41.6[us] <b>opck=8:</b> (intu * 256 + intl) * 0.2[us] + 13.2[us] <b>opck=9:</b> (intu * 256 + intl) * 0.2[us] + 26.0[us] <b>opck=11:</b> (intu * 256 + intl) * 0.2[us] + 12.5[us] <b>opck=13:</b> (intu * 256 + intl) * 0.2[us] + 24.5[us] <b>opck=14:</b> (intu * 256 + intl) * 0.2[us] + 41.5[us] <b>opck=15:</b> (intu * 256 + intl ) * 0.2[us] + 48.6[us] <b>opck=16:</b> (intu * 256 + intl ) * 0.2[us] + 82.6[us]

		<p>FS-C8KU7DCL</p> <p><b>opck=1:</b> <math>(intu * 256 + intl) * 0.4[us] + 41.6[us]</math></p> <p><b>opck=2:</b> <math>(intu * 256 + intl) * 0.4[us] + 48.5[us]</math></p> <p><b>opck=3:</b> <math>(intu * 256 + intl) * 0.4[us] + 82.5 [us]</math></p> <p><b>opck=4:</b> <math>(intu * 256 + intl) * 0.4[us] + 24.8[us]</math></p> <p><b>opck=5:</b> <math>(intu * 256 + intl) * 0.4[us] + 41.6[us]</math></p> <p><b>opck=8:</b> <math>(intu * 256 + intl) * 0.4[us] + 26.0[us]</math></p> <p><b>opck=9:</b> <math>(intu * 256 + intl) * 0.4[us] + 51.6[us]</math></p> <p><b>opck=10:</b> <math>(intu * 256 + intl) * 0.4[us] + 26.0[us]</math></p> <p><b>opck=11:</b> <math>(intu * 256 + intl ) * 0.4[us] + 24.8[us]</math></p> <p><b>opck=13:</b> <math>(intu * 256 + intl ) * 0.4[us] + 48.5[us]</math></p> <p><b>opck=14:</b> <math>(intu * 256 + intl) * 0.4[us] + 82.5[us]</math></p> <p><b>opck=15:</b> <math>(intu * 256 + intl) * 0.4[us] + 96.7[us]</math></p> <p><b>opck=16:</b> <math>(intu * 256 + intl) * 0.4[us] + 164.4[us]</math></p> <p><b>opck=21:</b> <math>(intu * 256 + intl) * 0.4[us] + 51.6[us]</math></p> <p><b>opck=22:</b> <math>(intu * 256 + intl ) * 0.4[us] + 102.8[us]</math></p> <p><b>opck=24:</b> <math>(intu * 256 + intl ) * 0.4[us] + 26.0[us]</math></p> <p><b>opck=25:</b> <math>(intu * 256 + intl) * 0.4[us] + 41.6[us]</math></p> <p><b>opck=27:</b> <math>(intu * 256 + intl) * 0.4[us] + 26.0[us]</math></p> <p><b>opck=28:</b> <math>(intu * 256 + intl) * 0.4[us] + 41.6[us]</math></p> <p><b>opck=32:</b> <math>(intu * 256 + intl) * 0.4[us] + 48.5[us]</math></p> <p><b>opck=33:</b> <math>(intu * 256 + intl) * 0.4[us] + 51.6[us]</math></p> <p><b>opck=34:</b> <math>(intu * 256 + intl ) * 0.4[us] + 82.5[us]</math></p> <p><b>opck=35:</b> <math>(intu * 256 + intl ) * 0.4[us] + 24.8[us]</math></p> <p><b>opck=36:</b> <math>(intu * 256 + intl) * 0.4[us] + 26.0[us]</math></p> <p><b>opck=37:</b> <math>(intu * 256 + intl) * 0.4[us] + 41.6[us]</math></p> <p><b>opck=38:</b> <math>(intu * 256 + intl) * 0.4[us] + 48.5[us]</math></p> <p><b>opck=39:</b> <math>(intu * 256 + intl) * 0.4[us] + 51.6[us]</math></p> <p><b>opck=40:</b> <math>(intu * 256 + intl) * 0.4[us] + 82.5[us]</math></p> <p><b>opck=41:</b> <math>(intu * 256 + intl ) * 0.4[us] + 96.7[us]</math></p> <p><b>opck=42:</b> <math>(intu * 256 + intl ) * 0.4[us] + 102.8[us]</math></p> <p><b>opck=43:</b> <math>(intu * 256 + intl) * 0.4[us] + 164.4[us]</math></p> <p><b>opck=48:</b> <math>(intu * 256 + intl) * 0.4[us] + 26.0[us]</math></p> <p><b>opck=49:</b> <math>(intu * 256 + intl ) * 0.4[us] + 41.6[us]</math></p> <p><b>opck=51:</b> <math>(intu * 256 + intl ) * 0.4[us] + 26.0[us]</math></p> <p><b>opck=52:</b> <math>(intu * 256 + intl ) * 0.4[us] + 41.6[us]</math></p> <p><b>opck=59:</b> <math>(intu * 256 + intl ) * 0.4[us] + 83.1[us]</math></p>
T14	Exposure time (INTERNAL_MODE)	T13 – 2[us] – 12[clk]

## V. Pixel Data Output Modes

### A. Bayer Filter Pattern on the Sensor

- There are two lines on the sensor.
- Line 1 has Red and Green pixels, whereas Line 2 has Green and Blue pixels as a Bayer pattern.
- There is no gap on Line 1 and Line 2
- The “green” value for pixel 1 in line 1 is (Gr1), the “green” value for pixel 1 in line 2 is (Gb1).

**Figure of Bayer Filter Pattern**

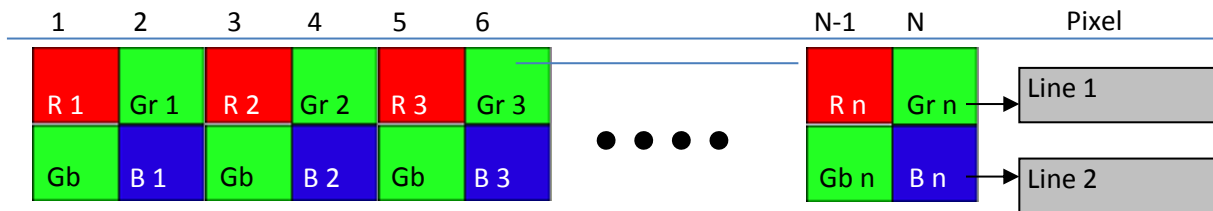

	FS-C2KU7DCL	FS-C4KU7DCL	FS-C8KU7DCL
N	2048	4096	8192
n	1024	2048	4096

R = Red Pixel  
 Gr = Green Pixel on Line 1  
 Gb = Green Pixel on Line 2  
 B = Blue Pixel

### Sensor Line Location

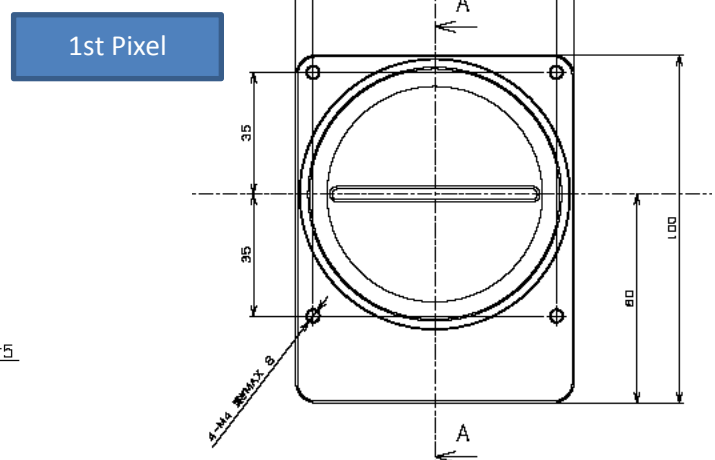
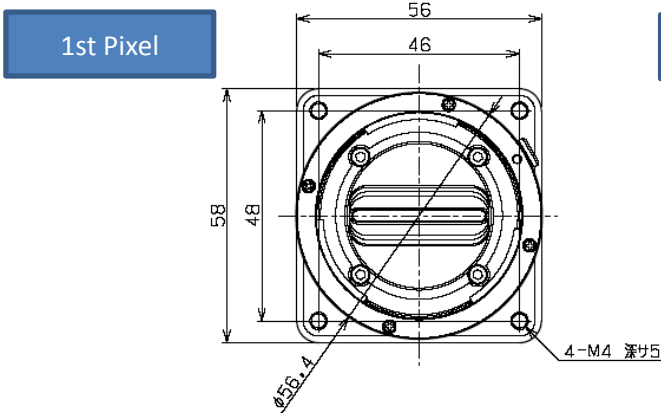

### Object Direction

Camera outputs one pixel data from several sensor data except opck=23,24,25. Therefore the object direction does not matter. Both directions should work. As for the opck=23,24,25. Object should move from top to bottom.

## B. Detail of Pixel Data Output Modes

### 1. Virtual Pixel 1 MODE

- This mode outputs over 3 Camera Link ports. The image is N pixels Bayer pattern sensor.
- In 3 TAP mode, Pixel data reads out from left to right on the sensor, and outputs over 3 Camera Link ports.
- In 6 tap mode, Pixel data reads out from left to center and center to right on the sensor, and outputs over 6 Camera Link ports.
- Green is the average value of Gr and Gb for Camera Link port.

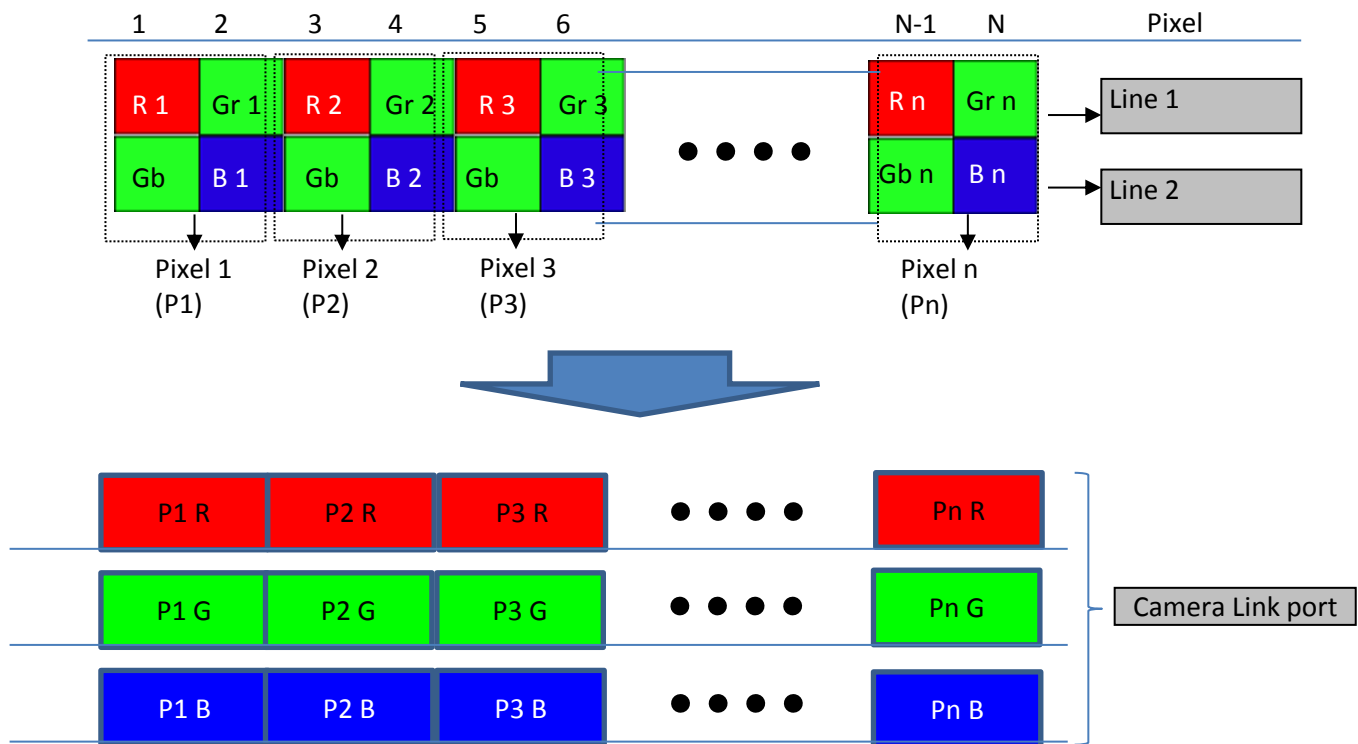

	FS-C2KU7DCL	FS-C4KU7DCL	FS-C8KU7DCL
N	2048	4096	8192
n	1024	2048	4096

- R = Red Pixel
- Gr = green Pixel on Line1
- Gb = Green Pixel on Line2
- B = Blue Pixel
- G = Average of Gr, Gb

## 2. Virtual Pixel 2 MODE

This mode outputs over 3 Camera Link ports.

Only 3 TAP mode.

Green on a Camera Link port is an average value of Gr, Gb.

The last pixel (Pixel (N)) must not be used for the non-pixel value used on the calculations.

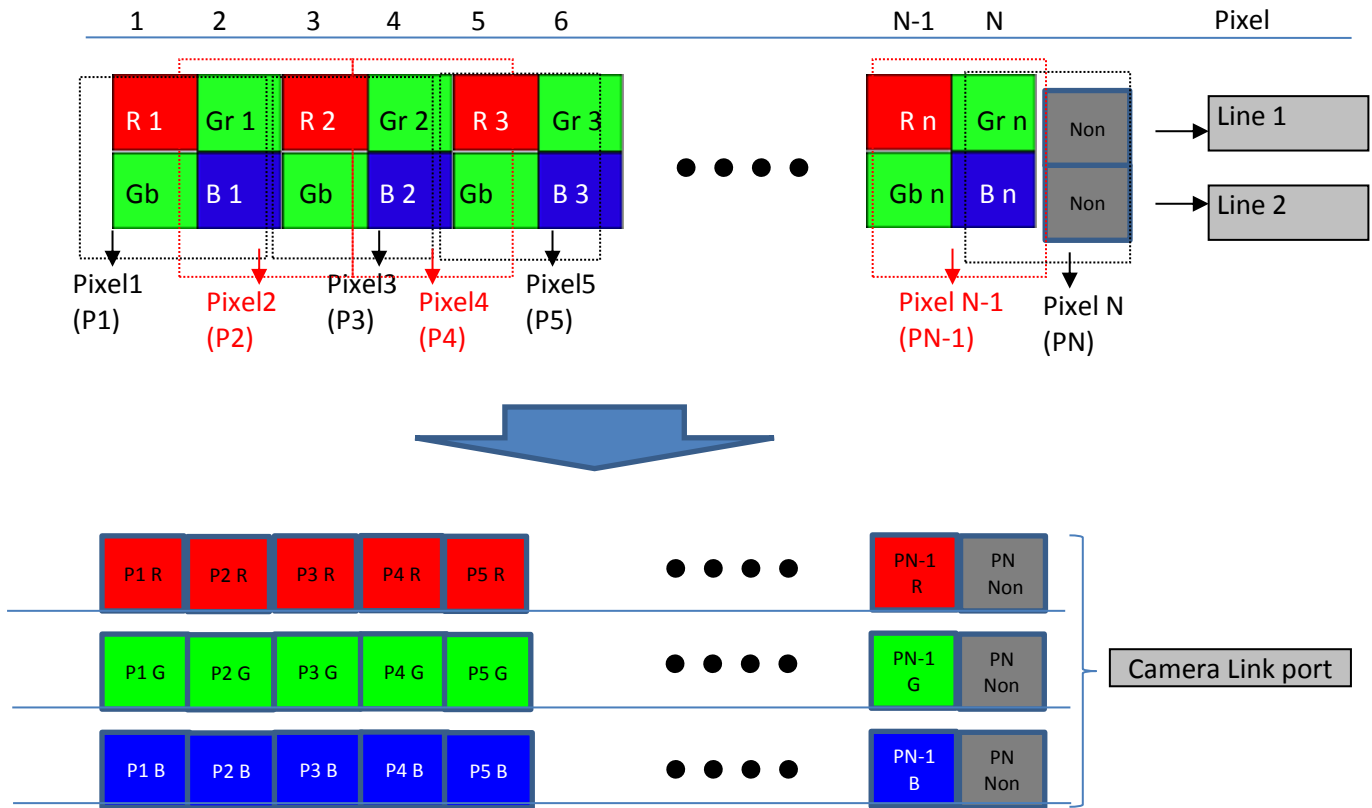

	FS-C2KU7DCL	FS-C4KU7DCL	FS-C8KU7DCL
N	2048	4096	8192
n	1024	2048	4096

R = Red pixel  
 Gr = Green Pixel on Line1  
 Gb = Green Pixel on Line2  
 B = Blue Pixel  
 G = Average of Gr,Gb

### 3. RAW2 MODE

This mode outputs over 4 Camera Link ports (4TAP) from Bayer pattern sensor.

In 4 TAP mode, Pixel data reads out for left to center. In 8TAP, Pixel data reads out from left to center and center to right on the sensor.

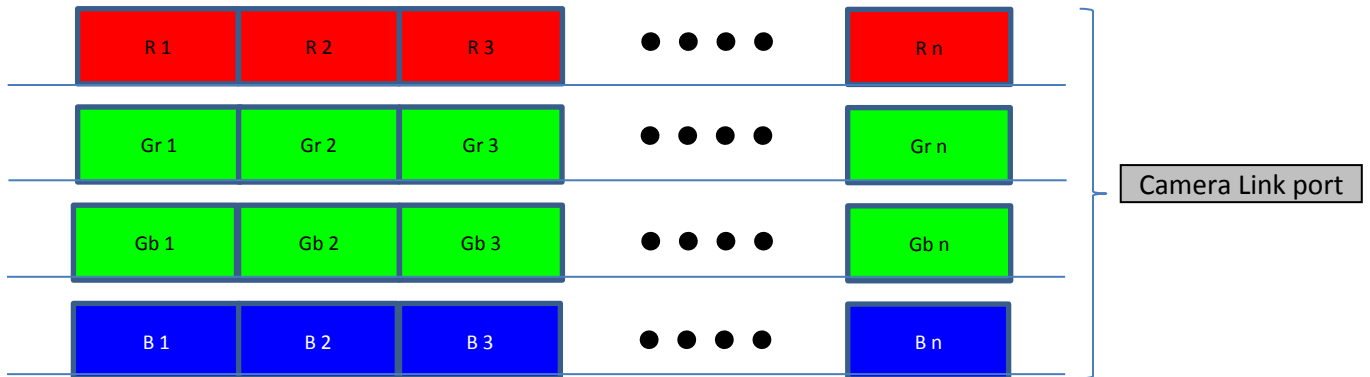
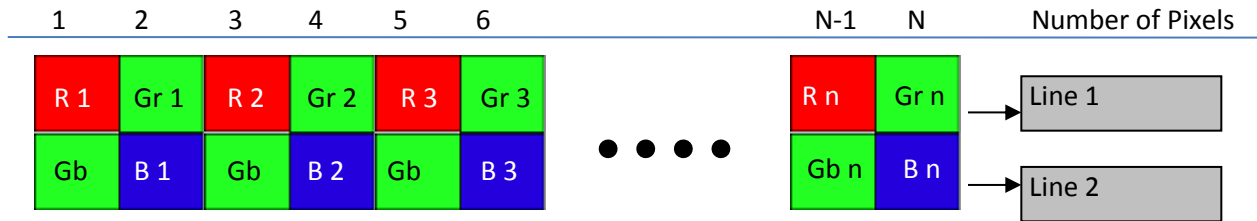

	FS-C2KU7DCL	FS-C4KU7DCL	FS-C8KU7DCL
N	2048	4096	8192
n	1024	2048	4096

R = Red Pixel

Gr = Green Pixel on Line1

Gb = Green Pixel on Line2

B = Blue Pixel

## 4. RAW MODE

This mode outputs over 2 Camera Link ports (2TAP) from Bayer pattern sensor.

In 2TAP mode, Pixel data reads out from left to center. In 4TAP, Pixel data reads out from left to center and center to right on the sensor.

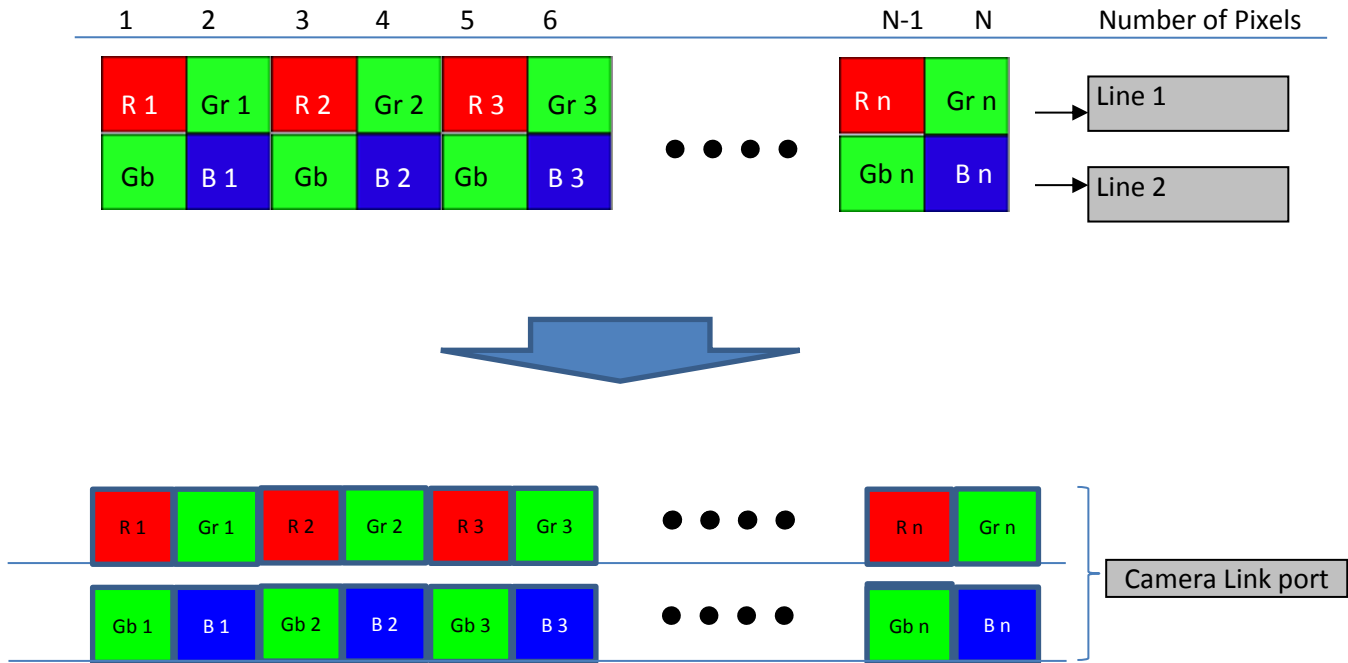

	FS-C2KU7DCL	FS-C4KU7DCL	FS-C8KU7DCL
N	2048	4096	8192
n	1024	2048	4096

R = Red Pixel

Gr = Green Pixel on Line1

Gb = Green Pixel on Line2

B = Blue Pixel

## 5. AOI MODE

Area of Interest image should be output.

Through the start pixel of video output and Width of LVAL setting, AOI can be output for each output mode.

Start pixel of video output can be set through command risu/risl.

Width of LVAL can be set through command riwu/riwl.

For the actual command, please refer to Section VIII (Command Description).

risu: Get Data Rate Mode

risl: Get the exposure time

riwu: Get the length of LVAL (The upper rank)

riwl: Get the length of LVAL (The lower rank)

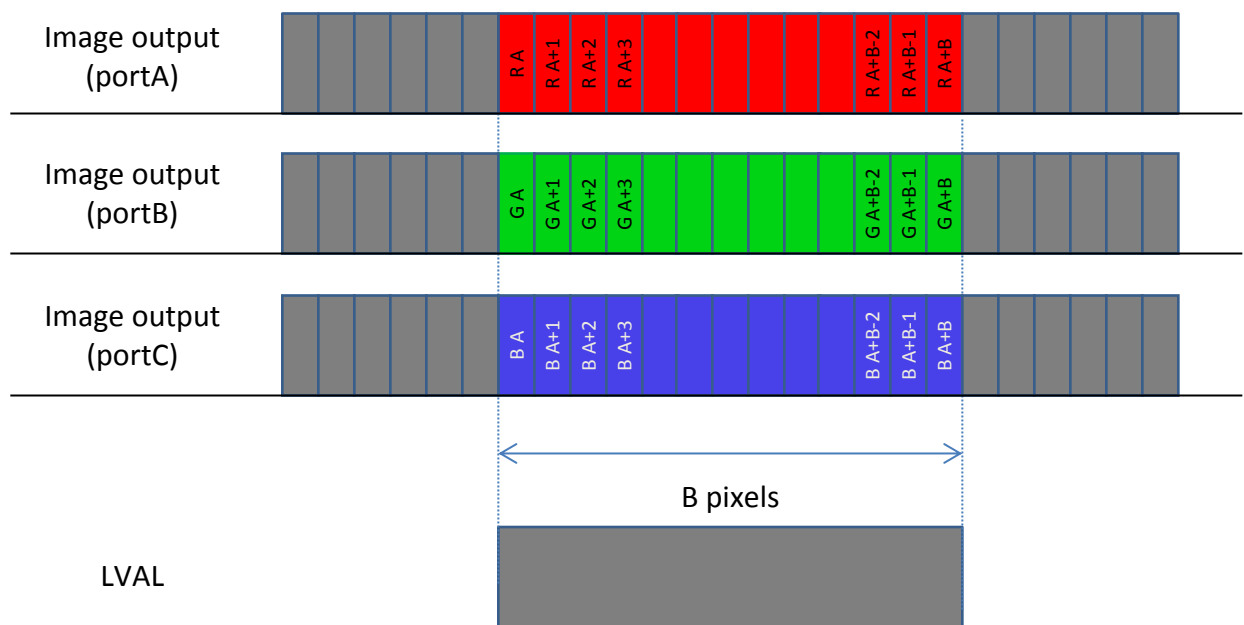

Offset : A Pixel

$$A = (\text{risu} \times 256) + \text{risl}$$

Width of AOI: B Pixels

$$B = (\text{riwu} \times 256) + \text{riwl}$$

R = Red Pixel

Gr = Green Pixel on Line1

Gb = Green Pixel on Line2

B = Blue Pixel

## 6. RAW Dual Line MODE

This mode is compatible with Basler (Line A First)

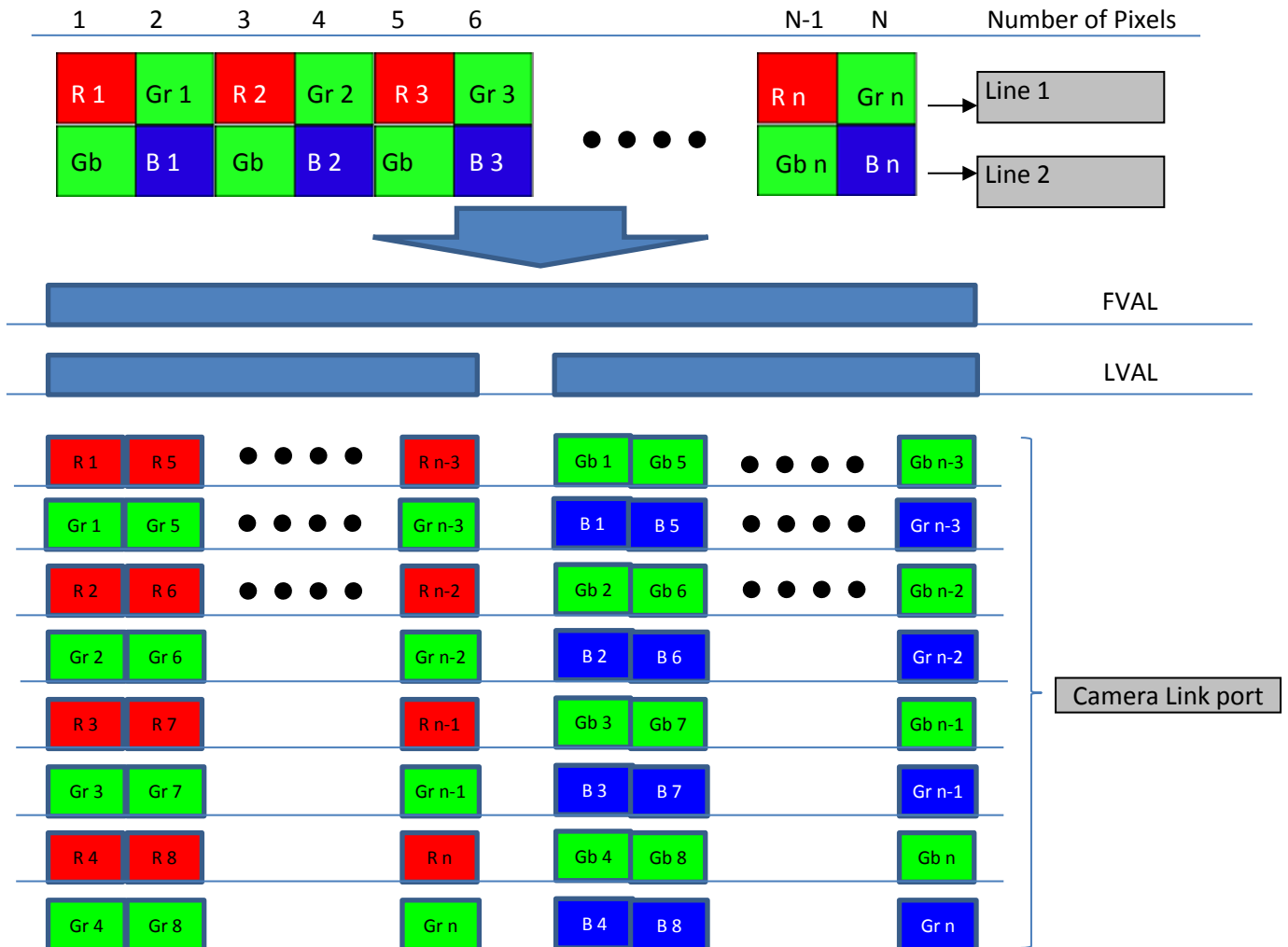

	FS-C4KU7DCL
N	4096
n	2048

R = Red Pixel  
 Gr = green Pixel on Line1  
 Gb = Green Pixel on Line2  
 B = Blue Pixel

## VI. Video Output Formats

### A. Video Output Format of FS-C2KU7DCL

- Selectable output modes are listed in the table below.
- Video output format can be selected through command opck.
- Another mode should not be used.
- Command opbt can change 8bit / 10bit.
- 10 bit output should be followed via Camera Link Specifications.

For actual commands please refer to Section VIII (Command Description).

opck: Get Data Rate Mode

opbt: Output bit setting

opck	Output mode	Output pixels	Taps	Output bit (opbt)	Max line rate	Camera link clock	Sensor mode
11	RGB (Virtual Pixel1)	1024 x RGB	3	8bit or 10bit	80kHz	85MHz	9bit
8					75kHz	80MHz	
1					46kHz	50MHz	
13	RGB (Virtual Pixel2)	2048 x RGB	3	8bit or 10bit	40.5kHz	85MHz	
21					38.5kHz	80MHz	
14					24kHz	50MHz	
4	RAW2	2048x R,GR,GB,B	4	8bit or 10bit	80kHz	85MHz	9bit
10					75kHz	80MHz	
5					46kHz	50MHz	
35	RAW	2048x R/GR,GB/B	4	8bit or 10bit	80kHz	85MHz	9bit
36					75kHz	80MHz	
37					46kHz	50MHz	
39					75kHz	80MHz	
40			46kHz		50MHz		
			2		75kHz	80MHz	
27	AOI RGB (Virtual Pixel1)	1-1024 x RGB	3	8bit or 10bit	75kHz	80MHz	
28					46kHz	50MHz	
59	RGB (Virtual Pixel1)	1024 x RGB	3	8bit or 10bit	23.5kHz	25MHz	

### Technical Terminology

Word	Description
(9bit)	9bit mode is that output 9bit data to increase the frame rate for reducing the output bit 10 to 9bit(Sensor still send 10 bit even in this mode). FFC value is saved for another FFC value for sensor's behavior is different from normal one.
Taps	It describes port number on 8bit camera link output. Number of cable is made effect for this Tap number( 2,3 Tap(8bit): 1 cable,4 Tap(8bit): 2 cables ).
Output pixels	This number describes the amount of data that output from camera.
Camera link clock	This number describes the clock speed of camera link output. Clock speed could make effect the selectable cable length. Shorter cable can sent faster clock.

1. 8 bit x 3 tap RGB (Virtual Pixel 1)

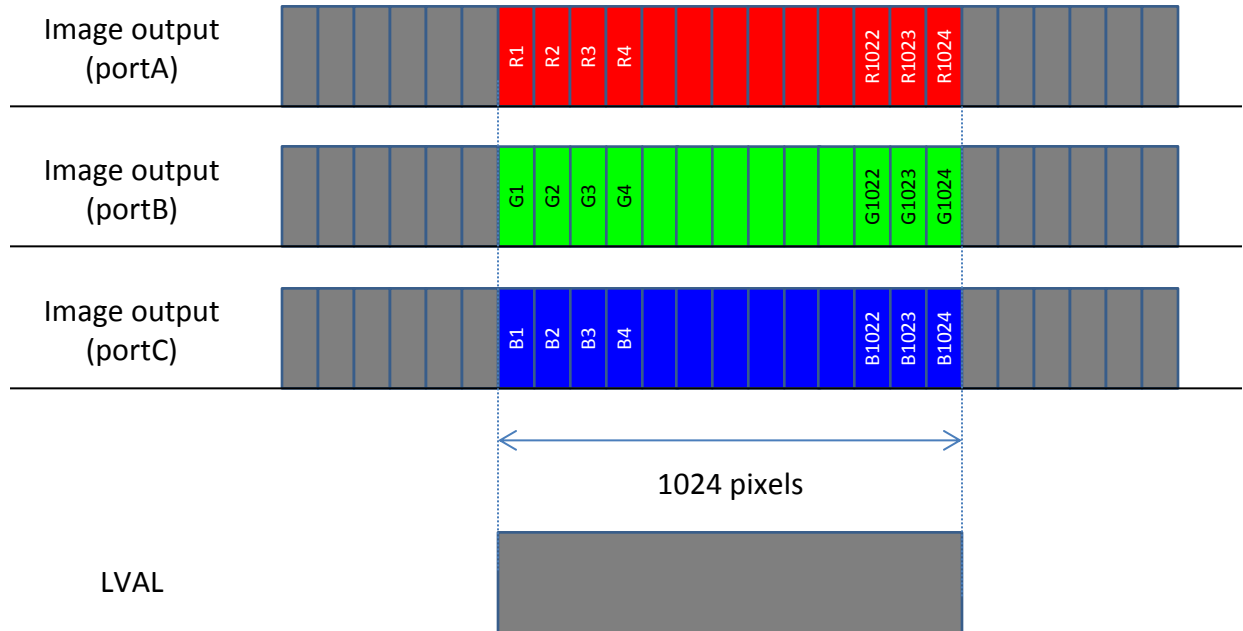

2. 10 bit x 3 tap RGB (Virtual Pixel 1)  
 Follow as per Camera Link Specifications.  
 (This works on Medium Configuration)

3. 8 bit x 3 tap RGB (Virtual Pixel 2)

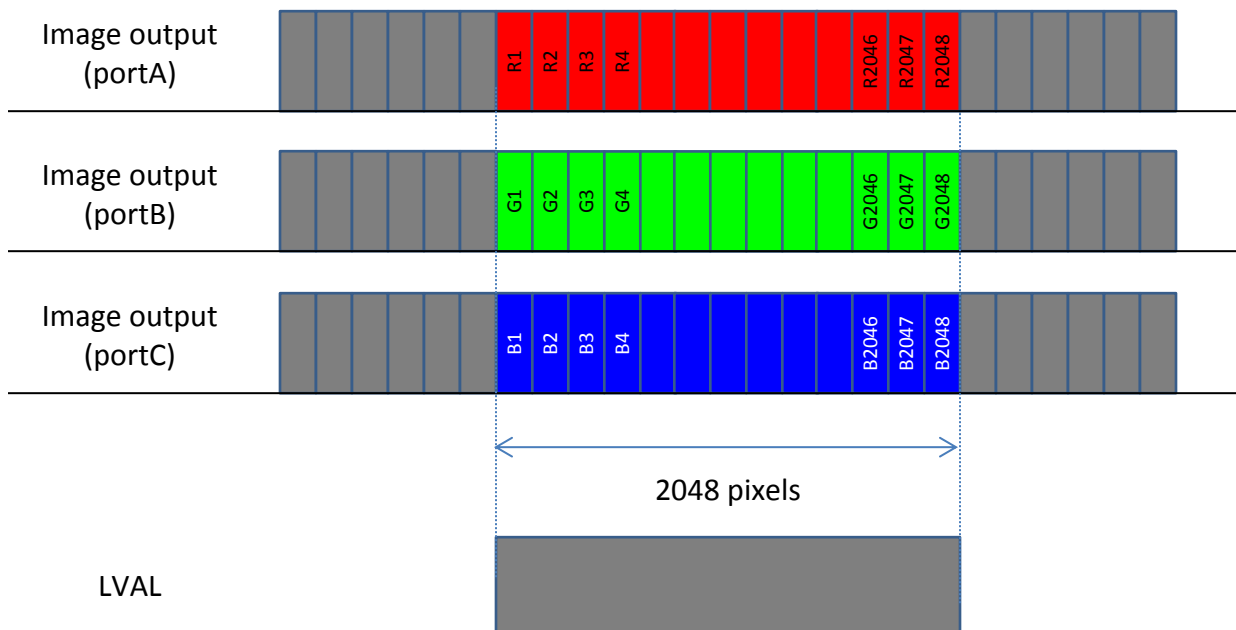

4. 10 bit x 3 tap RGB (Virtual Pixel 2)  
 Follow as per Camera Link Specifications  
 (This works on Medium Configuration)

5. 8 bit x 4 tap RAW Color

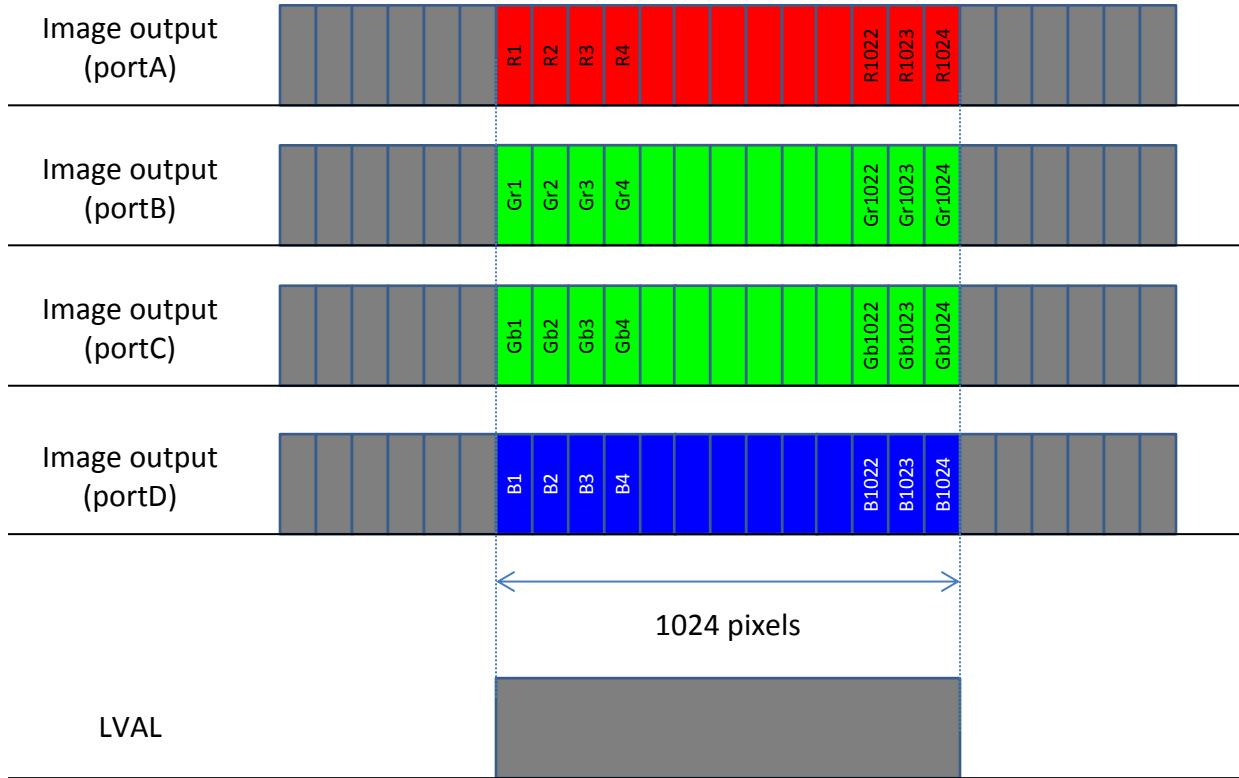

6. 10 bit x 4 tap RAW Color  
 Follow as per Camera Link Specifications  
 (This works on Medium Configuration)

## 7. 8 bit x 4 tap RAW Direct

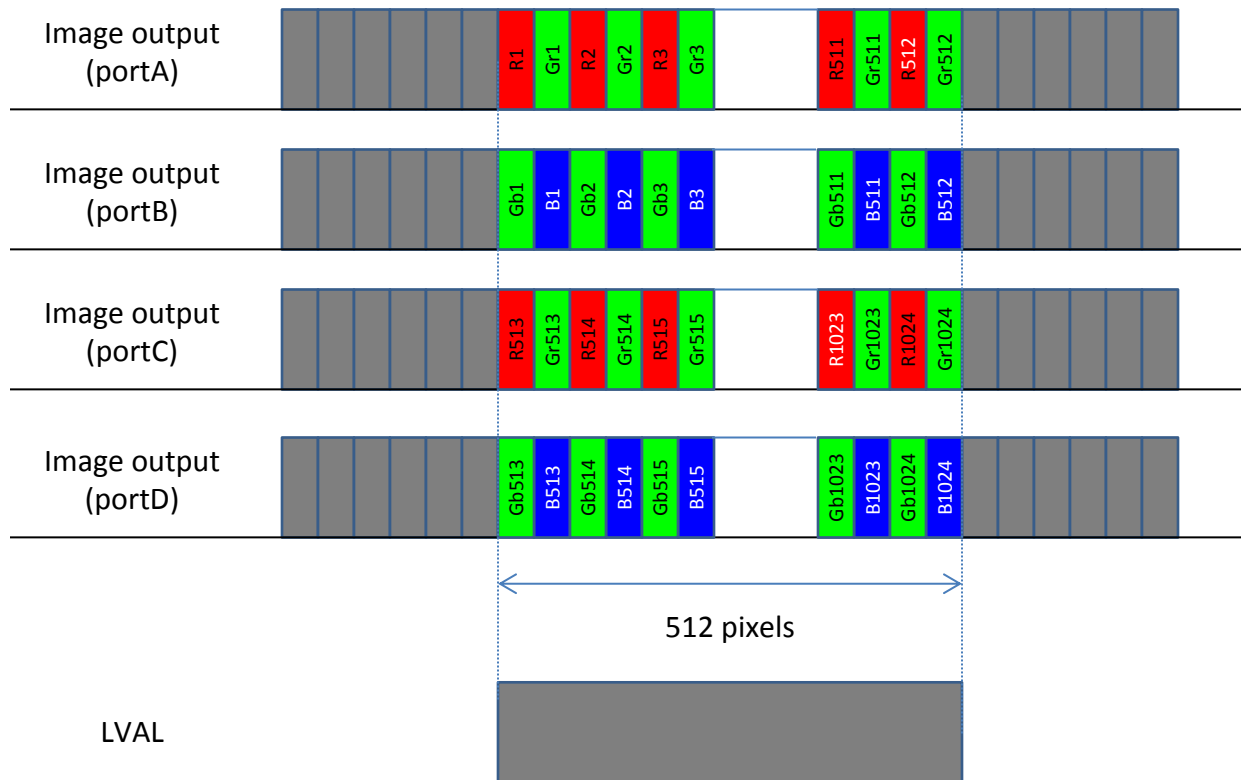

## 8. 10 bit x 4 tap RAW Direct

Follow as per Camera Link Specifications.

## 9. 8 bit x 8 tap RAW

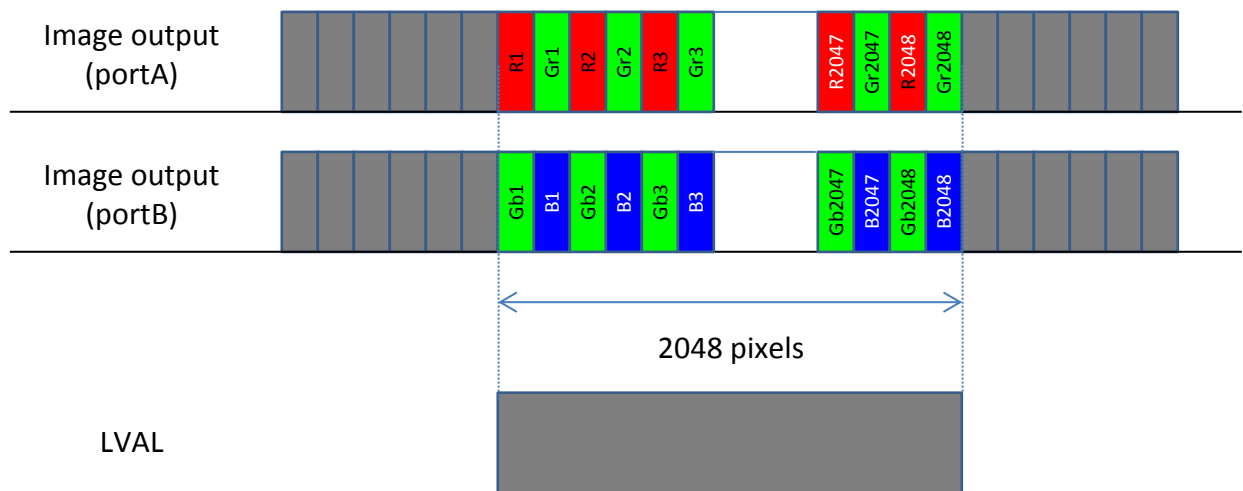

10. 10 bit x 2 tap RAW Direct  
Follow as per Camera Link Specifications.

## B. Video Output format of FS-C4KU7DCL

- Selectable output modes are listed in the table below.
- Video output format can be selected through command opck.
- Another mode should not be used.
- Command opbt can change 8bit / 10bit.
- 10 bit output should be followed via Camera Link Specifications.

For actual commands please refer to Section VIII (Command Description).

opck: Get Data Rate Mode

opbt: Output bit setting

opck	Output mode	Output pixels	Taps	Output bit (opbt)	Max line rate	Camera link clock	Sensor mode
11	RGB (Virtual Pixel1)	2048 x RGB	6	8bit	80kHz	85MHz	9bit
8					75kHz	80MHz	
1					46kHz	50MHz	
2			3	8bit or 10bit	40.5kHz	85MHz	
9					38.5kHz	80MHz	
3					24kHz	50MHz	
13	RGB (Virtual Pixel2)	4096 x RGB	6	8bit	40.5kHz	85MHz	
21					38.5kHz	80MHz	
14					24kHz	50MHz	
15			3	8bit or 10bit	20.5kHz	85MHz	
22					19kHz	80MHz	
16					12kHz	50MHz	
4	RAW Color	2048 x R,GR,GB,B	8	8bit	80kHz	85MHz	9bit
10					75kHz	80MHz	
5					46kHz	50MHz	
32			4	8bit or 10bit	40.5kHz	85MHz	
33					38.5kHz	80MHz	
34					24kHz	50MHz	
35	RAW Direct	2048 x R/GR,GB/B	8	8bit	80kHz	85MHz	9bit
36					75kHz	80MHz	
37					46kHz	50MHz	
38					4	8bit or 10bit	40.5kHz
39			38.5kHz	80MHz			
40			24kHz	50MHz			
41			2	8bit or 10bit			20.5kHz
42					19kHz	80MHz	
43	12kHz	50MHz					
27	AOI RGB (Virtual Pixel1)	1-2048 x RGB	3	8bit or 10bit	75kHz	80MHz	
28					46kHz	50MHz	
48	AOI RAW Direct	1-2048 x R/GR,GB/B	2	8bit or 10bit	75kHz	80MHz	
49					46kHz	50MHz	
51	AOI RAW Color	1-4096 x R,GR,GB,B	4	8bit or 10bit	75kHz	80MHz	
52					46kHz	50MHz	
24	AOI Raw Dual Line	1-512 x R/GR,GB/B	8	8bit	75kHz	80MHz	
25					46kHz	50MHz	
59	RGB (Virtual Pixel1)	2048 x RGB	6	8bit	23.5kHz	25MHz	

## Technical Terminology

Word	Description
(9bit)	9bit mode is that output 9bit data to increase the frame rate for reducing the output bit 10 to 9bit(Sensor still send 10 bit even in this mode). FFC value is saved for another FFC value for sensor's behavior is different from normal one.
Taps	It describes port number on 8bit camera link output. Number of cable is made effect for this Tap number( 2,3 Tap(8bit): 1 cable,4 Tap(8bit): 2 cables ).
Output pixels	This number describes the amount of data that output from camera.
Camera link clock	This number describes the clock speed of camera link output. Clock speed could make effect the selectable cable length. Shorter cable can sent faster clock.

1. 8 bit x 6 tap RGB (Virtual Pixel 1)

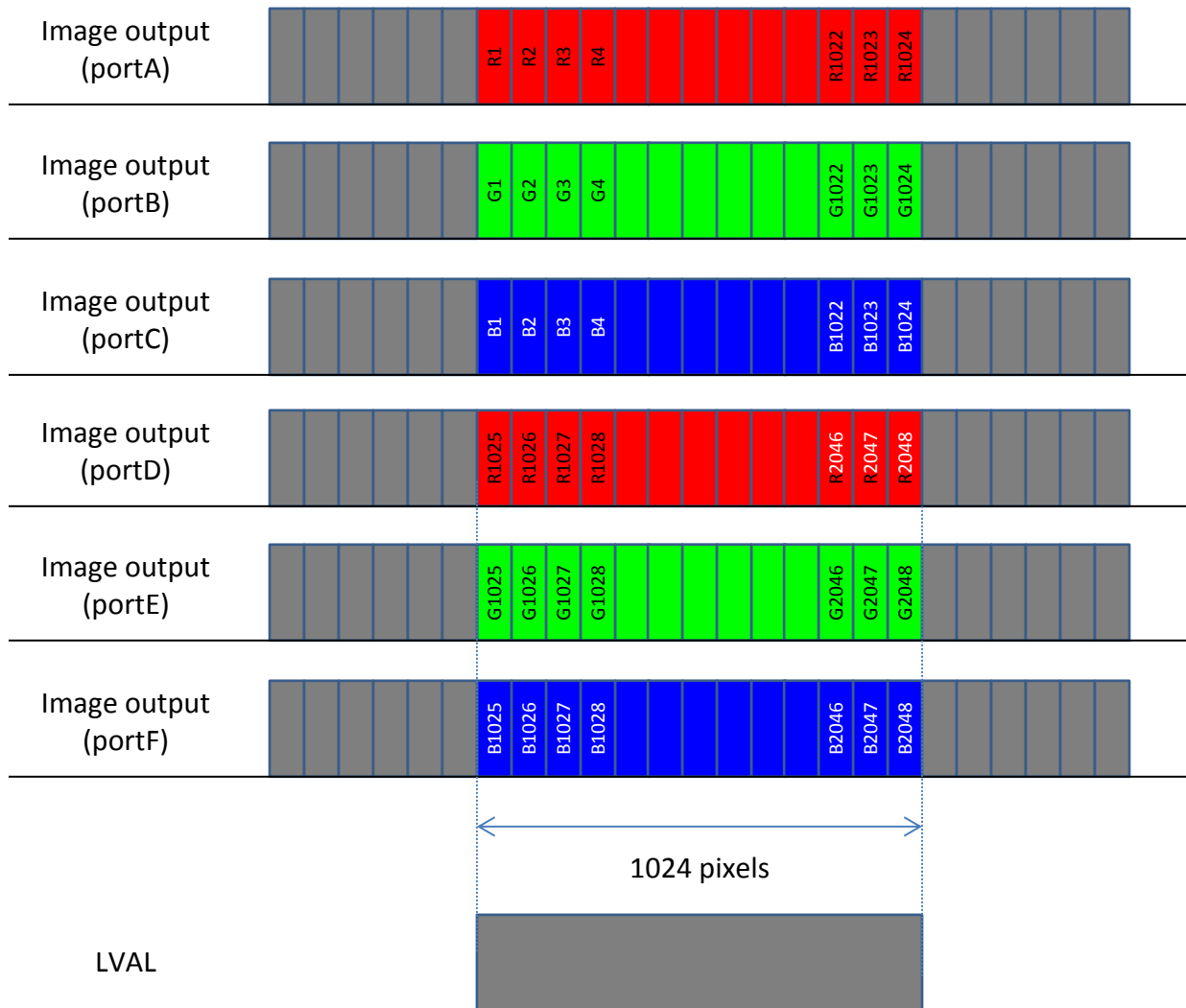

## 2. 8 bit x 3 tap RGB (Virtual Pixel 1)



3. 10 bit x 3 tap RGB (Virtual Pixel 1)  
Follow as per Camera Link Specifications.  
(This works on Medium Configuration)



## 5. 8 bit x 3 tap RGB (Virtual Pixel 2)

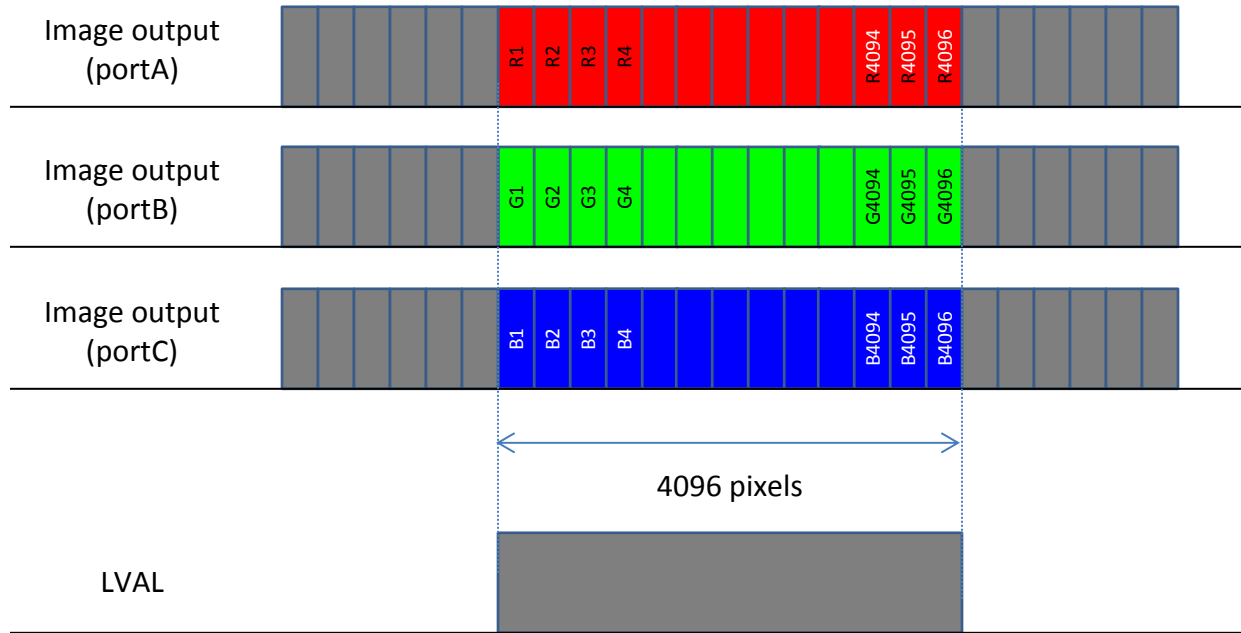

## 6. 10 bit x 3 tap RGB (Virtual Pixel 2) Follow as per Camera Link Specifications (This works on Medium Configuration)

## 7. 8 bit x 8 tap RAW Color

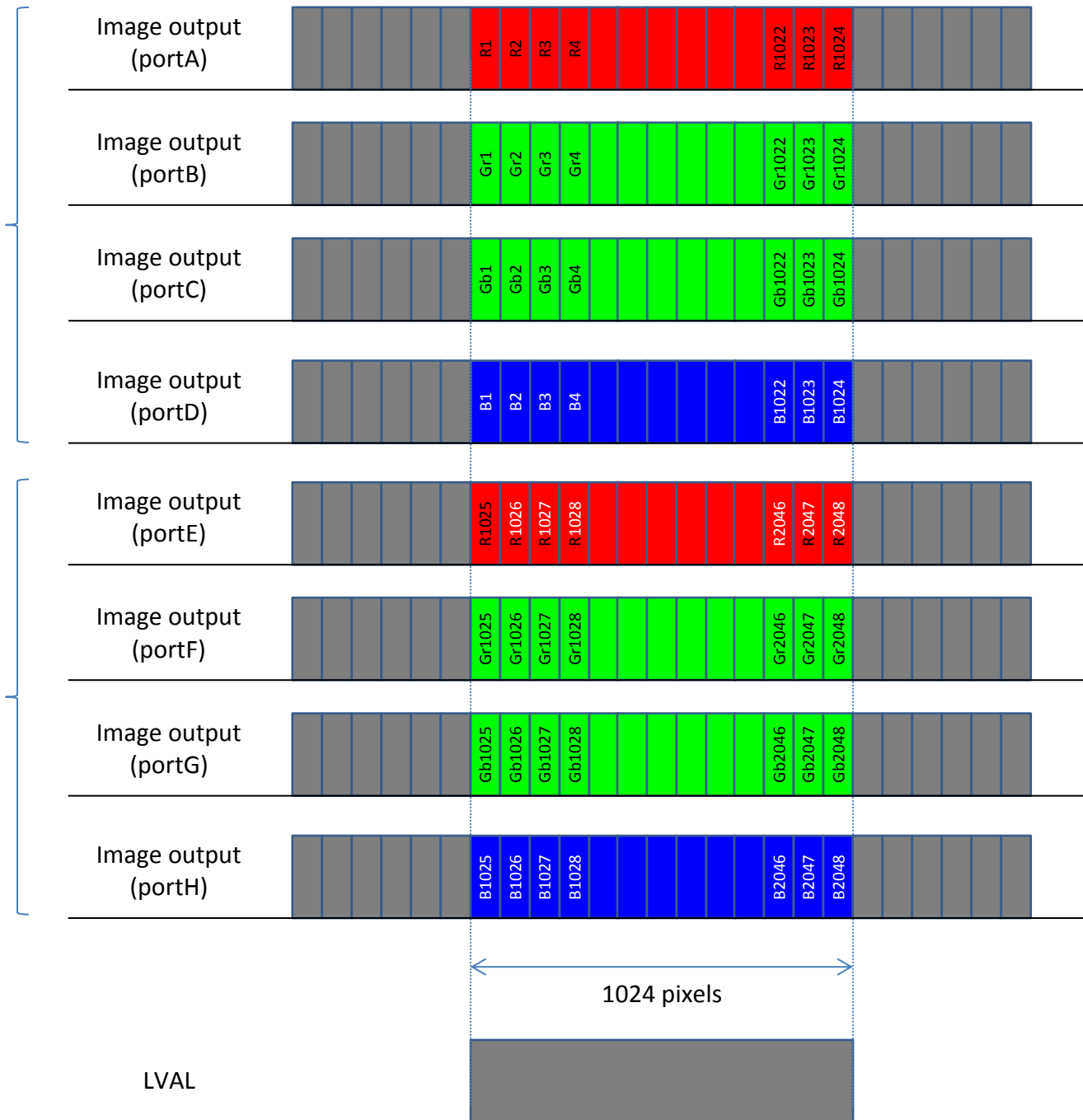

## 8. 10 bit x 8 tap RAW Color

Follow as per Camera Link Specifications.

## 9. 8 bit x 4 tap RAW Color

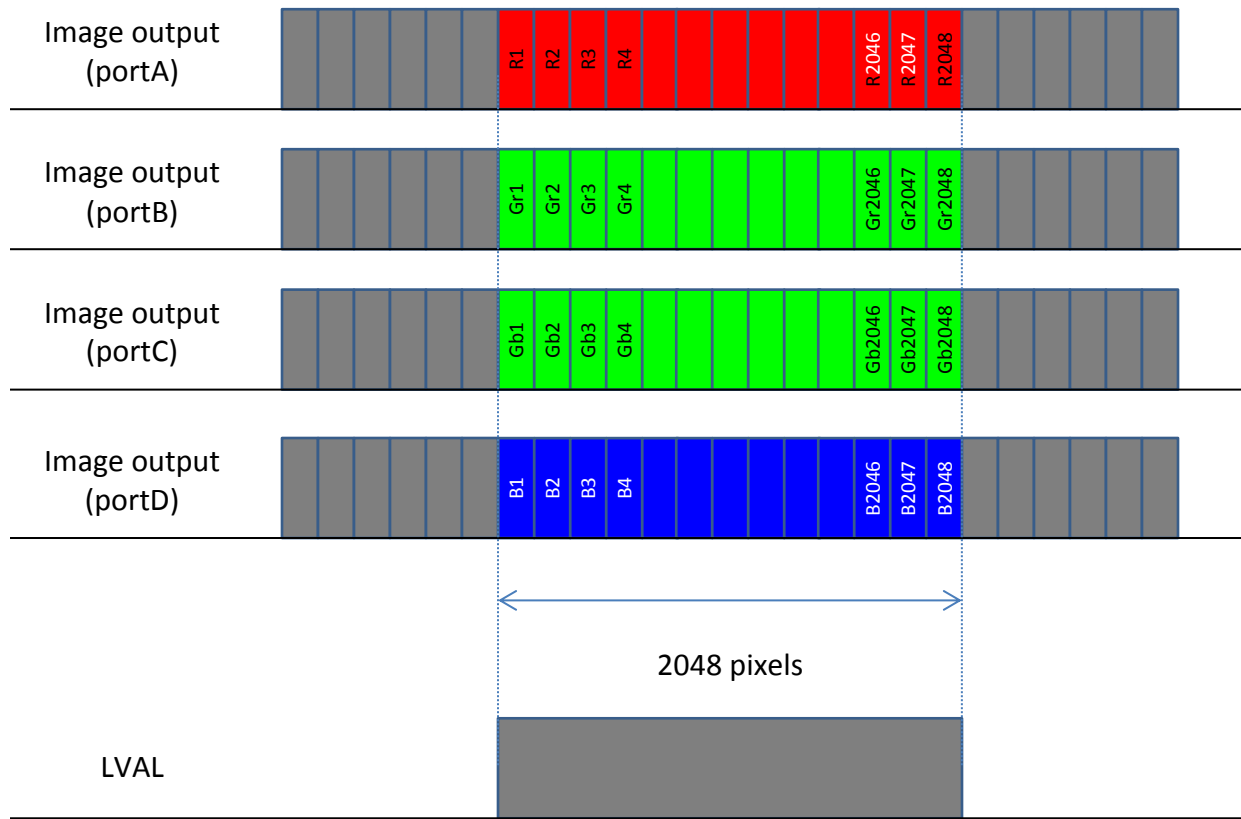

## 10. 10 bit x 4 tap RAW Color

Follow as per Camera Link Specifications.

## 11. 8 bit x 8 tap RAW Direct

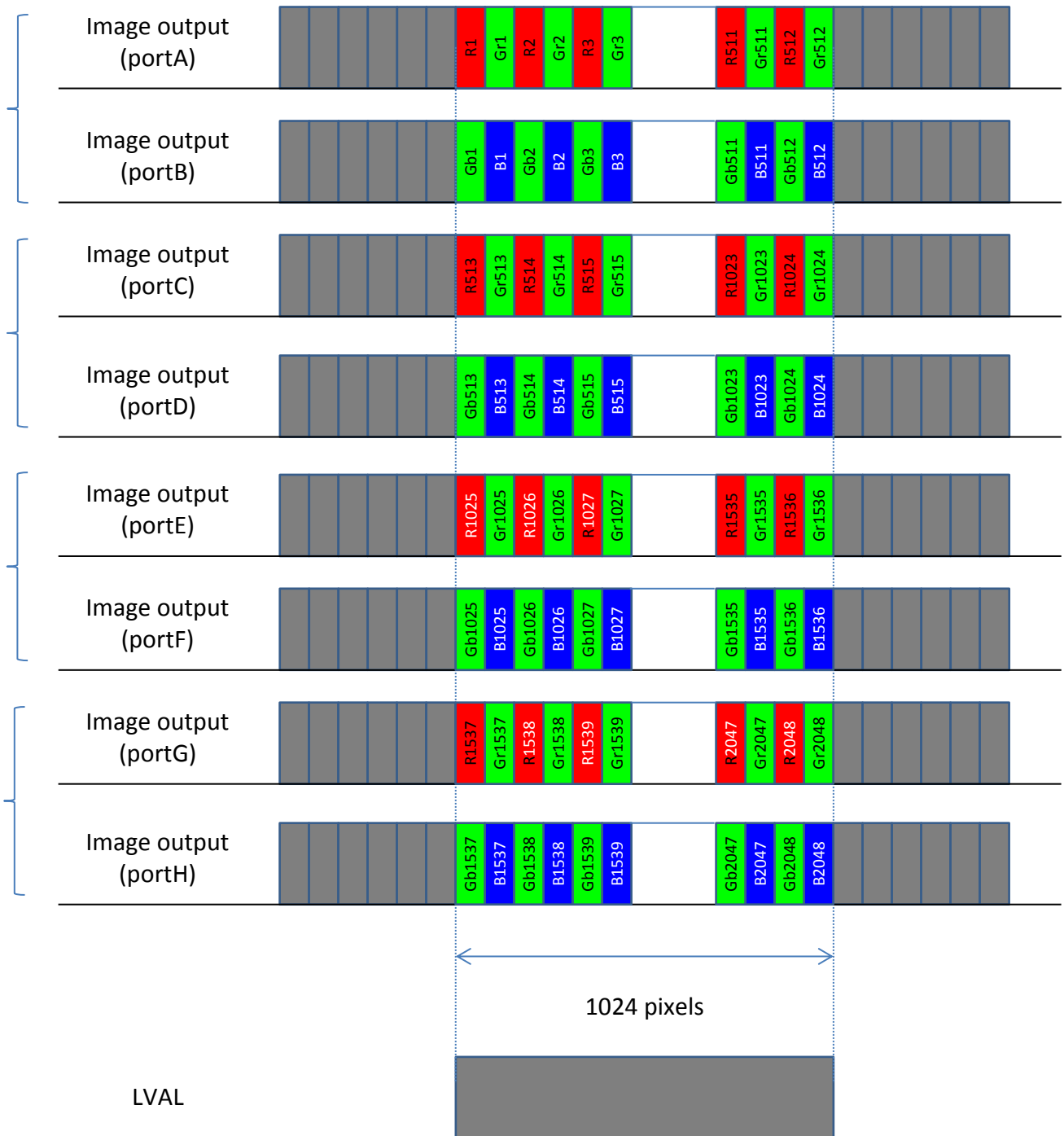

## 12. 8 bit x 4 tap RAW Direct

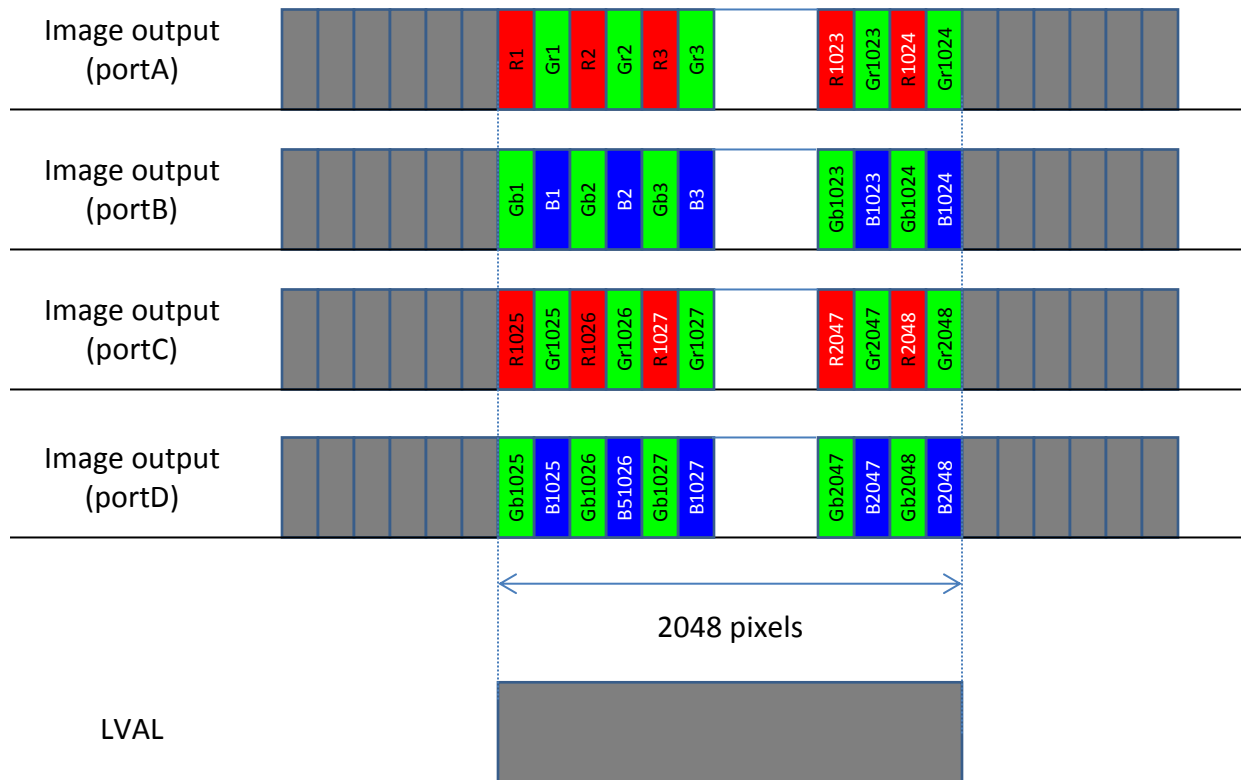

## 13. 10 bit x 4 tap RAW Direct

Follow as per the Camera Link Specifications.

## 14. 8 bit x 2 tap RAW Direct

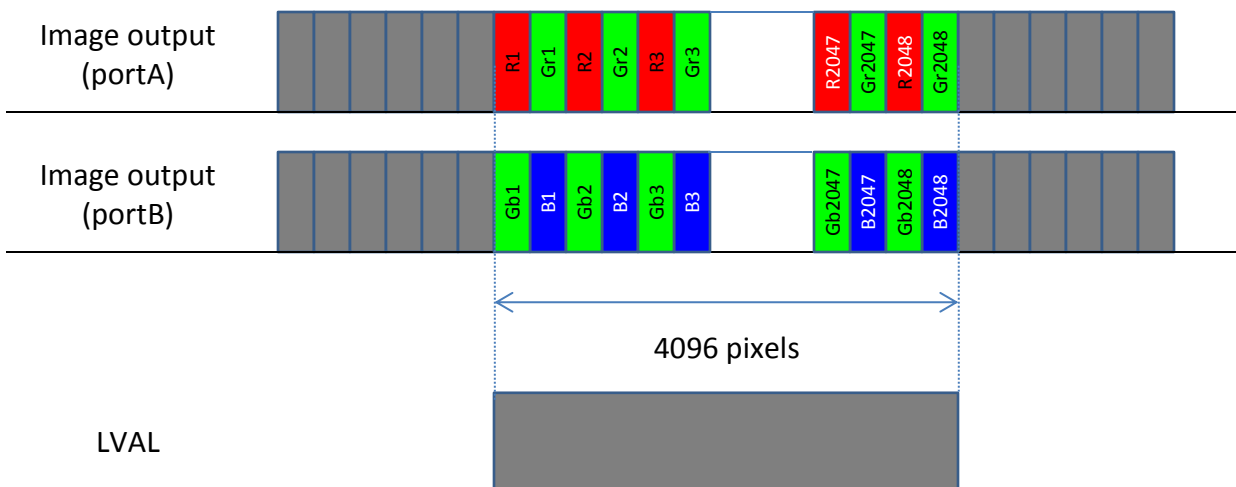

15. 10 bit x 2 tap RAW Direct  
Follow as per Camera Link Specifications.

16. 8 bit x 8 tap Raw Dual Line

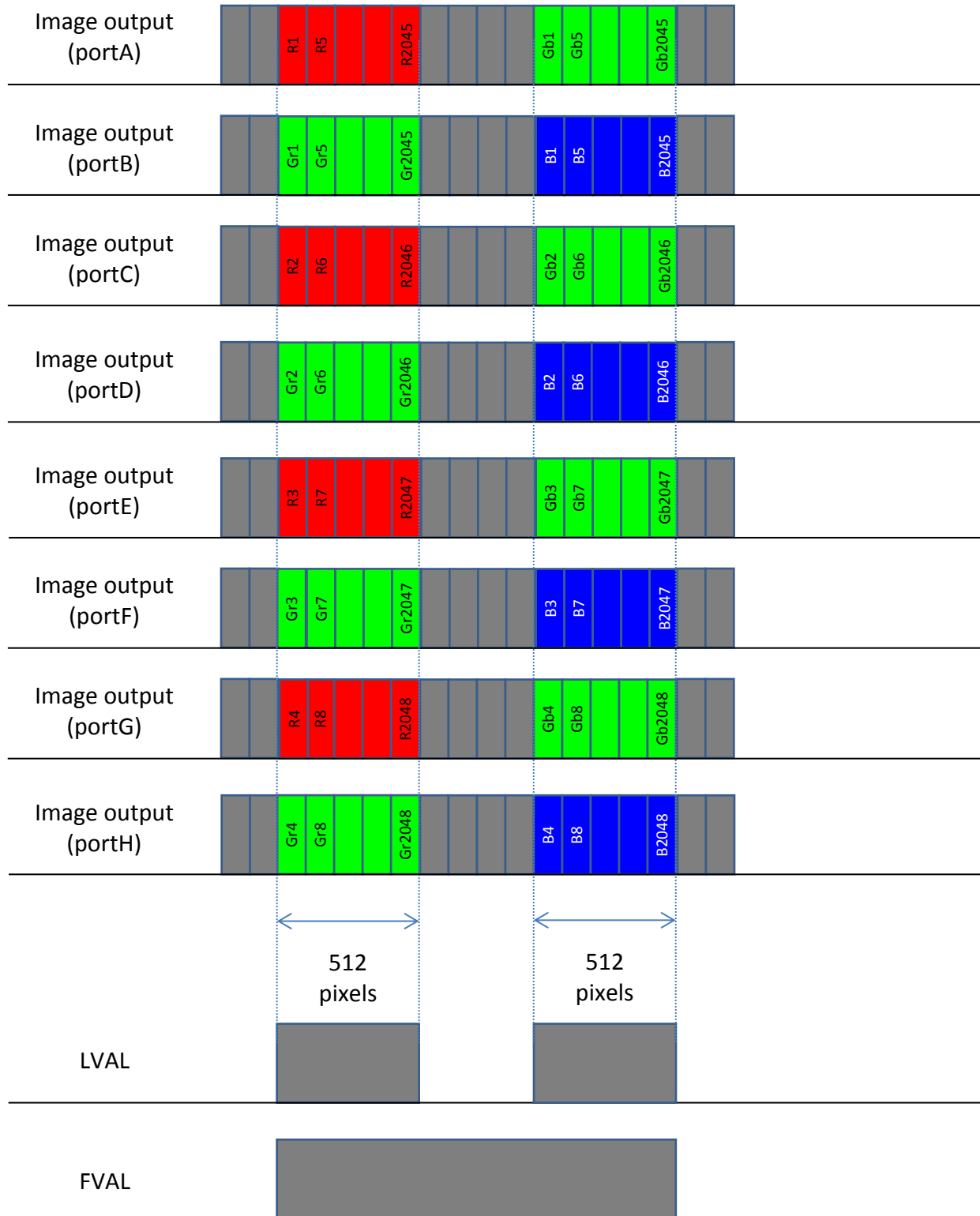

### C. Video Output Format of FS-C8KU7DCL

Selectable output modes are listed in the table below.

Video output format can be selected through the command opck.

Any other modes should not be used.

Command opbt can change 8 bit / 10 bit.

10 bit output should be used as per Camera Link Specifications.

For the actual commands please refer to Section VIII : Command Description.

opck: Get data rate mode

opbt : Output bit setting

opck	Output mode	Output pixels	Taps	Output bit	MaxLinerate	CameralinkClock	SensorMode
11	RGB (Virtual Pixel1)	4096 x RGB	6	8bit	40kHz	85MHz	9bit
8					38.5kHz	80MHz	
1					24kHz	50MHz	
2			3	8bit or 10bit	20.5kHz	85MHz	
9					19kHz	80MHz	
3					12kHz	50MHz	
13	RGB (Virtual Pixel2)	8192 x RGB	6	8bit	20.5kHz	85MHz	
21					19kHz	80MHz	
14					12kHz	50MHz	
15			3	8bit or 10bit	10kHz	85MHz	
22					9.5kHz	80MHz	
16					6kHz	50MHz	
4	RAW Color	4096 x R,GR,GB,B	8	8bit	40kHz	85MHz	9bit
10					38.5kHz	80MHz	
5					24kHz	50MHz	
32			4	8bit or 10bit	20.5kHz	85MHz	
33					19kHz	80MHz	
34					12kHz	50MHz	
35	RAW Direct	4096 x R/GR,GB/B	8	8bit	40kHz	85MHz	9bit
36					38.5kHz	80MHz	
37					24kHz	50MHz	
38			4	8bit or 10bit	20.5kHz	85MHz	
39					19kHz	80MHz	
40					12kHz	50MHz	
41			2	8bit or 10bit	10kHz	85MHz	
42					9.5kHz	80MHz	
43	6kHz	50MHz					
27	AOI RGB (Virtual Pixel1)	1-4096 x RGB	3	8bit or 10bit	38.5kHz	80MHz	
28					24kHz	50MHz	
48	AOI RAW Direct	1-4096 x R/GR,GB/B	2	8bit or 10bit	38.5kHz	80MHz	
49					24kHz	50MHz	
51	AOI RAW Color	1-4096 x R,GR,GB,B	4	8bit or 10bit	38.5kHz	80MHz	
52					24kHz	50MHz	
24	Raw Dual Line	1-4096 x R/GR,GB/B	8	8bit	38.5kHz	80MHz	
25					24kHz	50MHz	
59	RGB	4096 x RGB	6	8bit	12kHz	25MHz	

## 1. 8 bit x 6 tap RGB (Virtual Pixel 1)

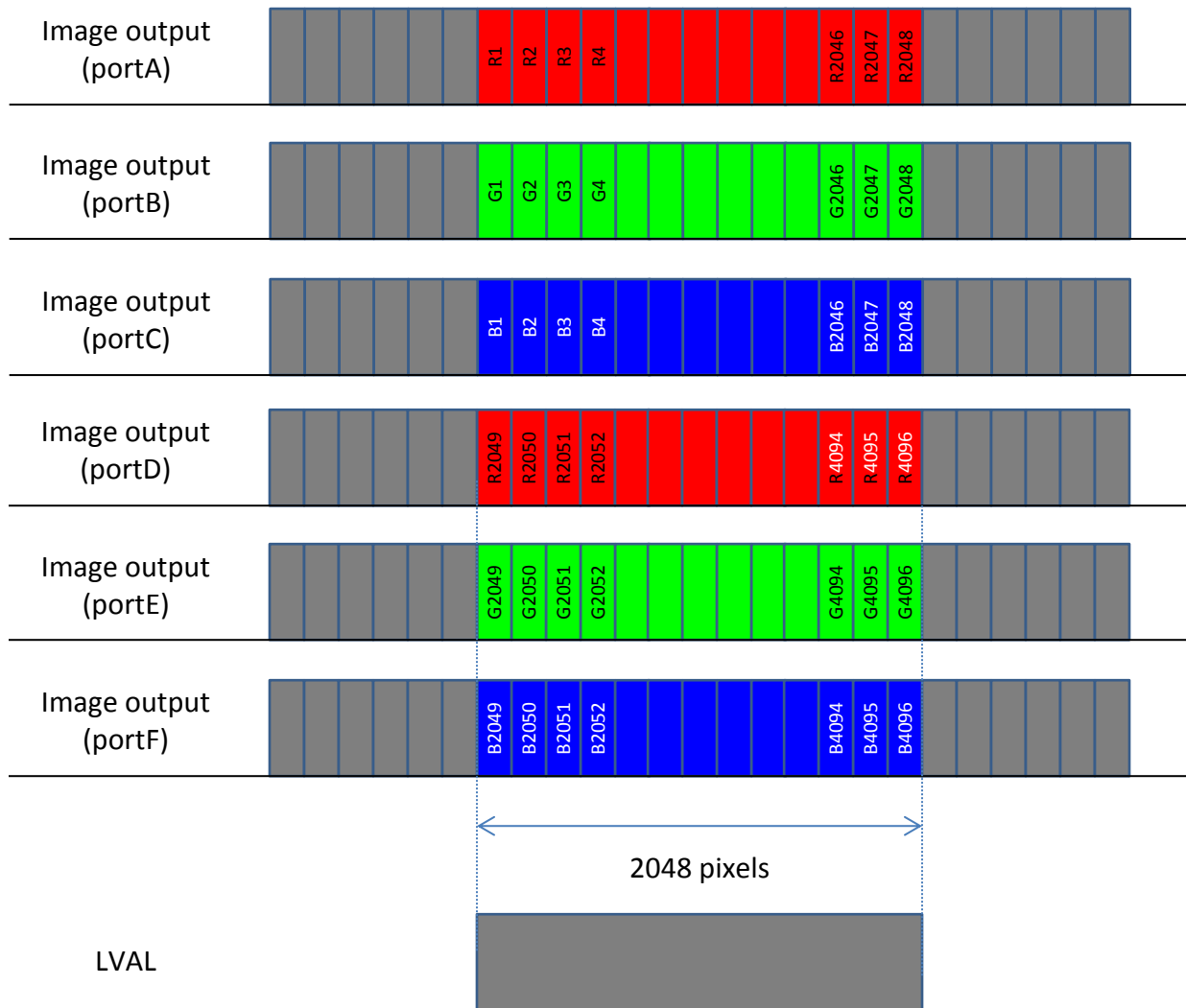

## 2. 8 bit x 3 tap RGB (Virtual Pixel 1)

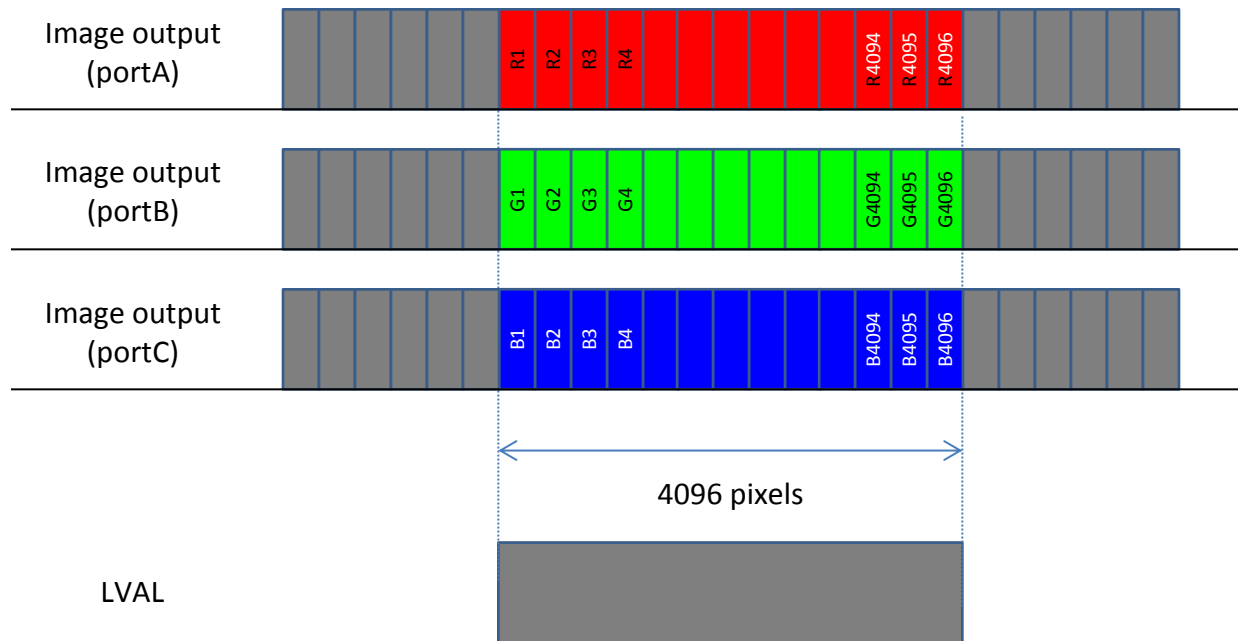

## 3. 10 bit x 3 tap RGB (Virtual Pixel 1) Follow as per Camera Link Specifications.

## 4. 8 bit x 3 tap RGB (Virtual Pixel 2)

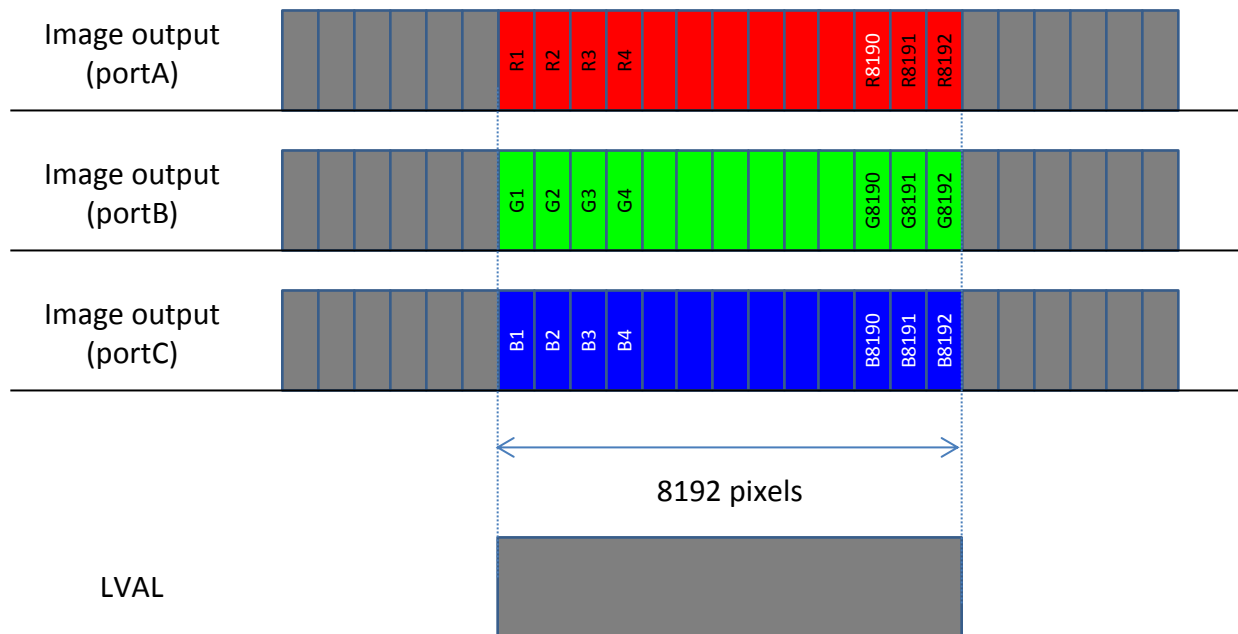



7. 10 bit x 8 tap RAW Color  
Follow as per Camera Lin Specifications

8. 8 bit x 4 tap RAW Color

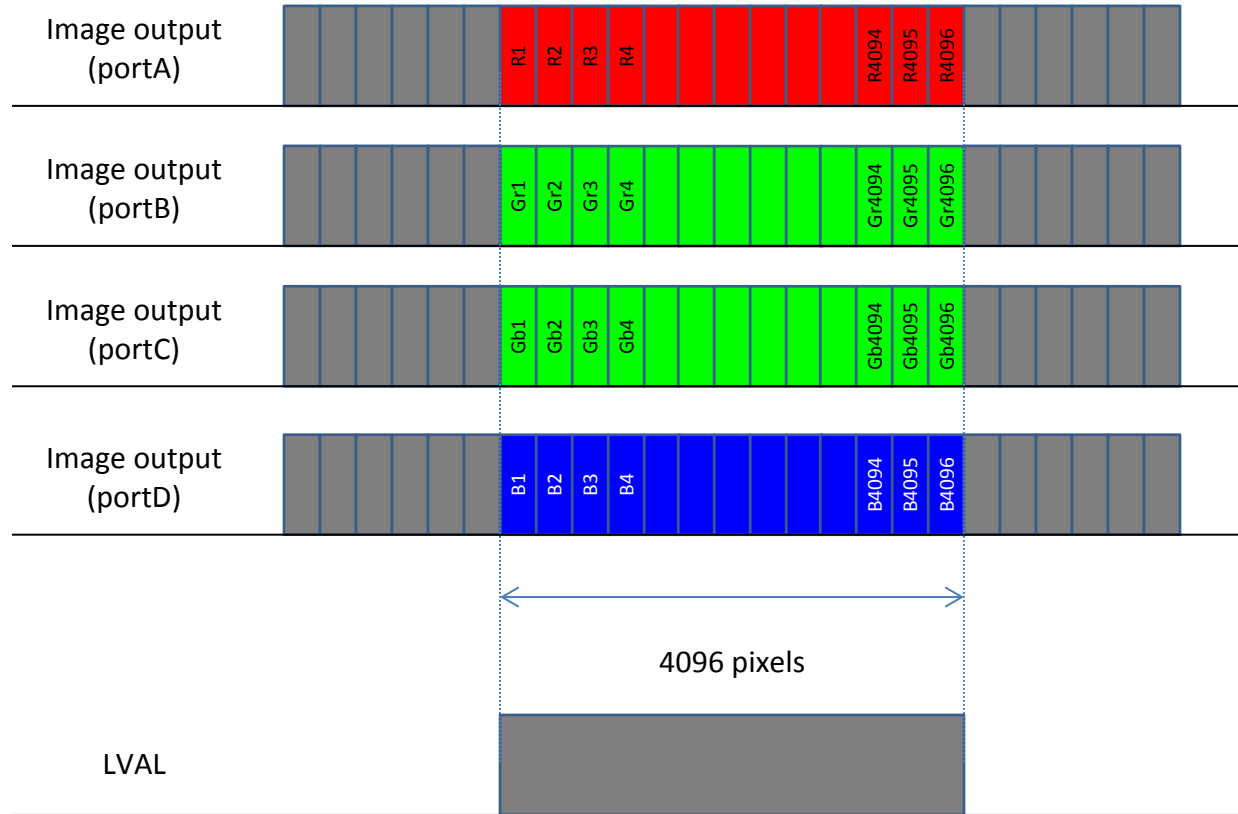

9. 10 bit x 4 tap RAW Color  
Follow as per Camera Link Specifications.

## 10. 8 bit x 8 tap RAW Direct

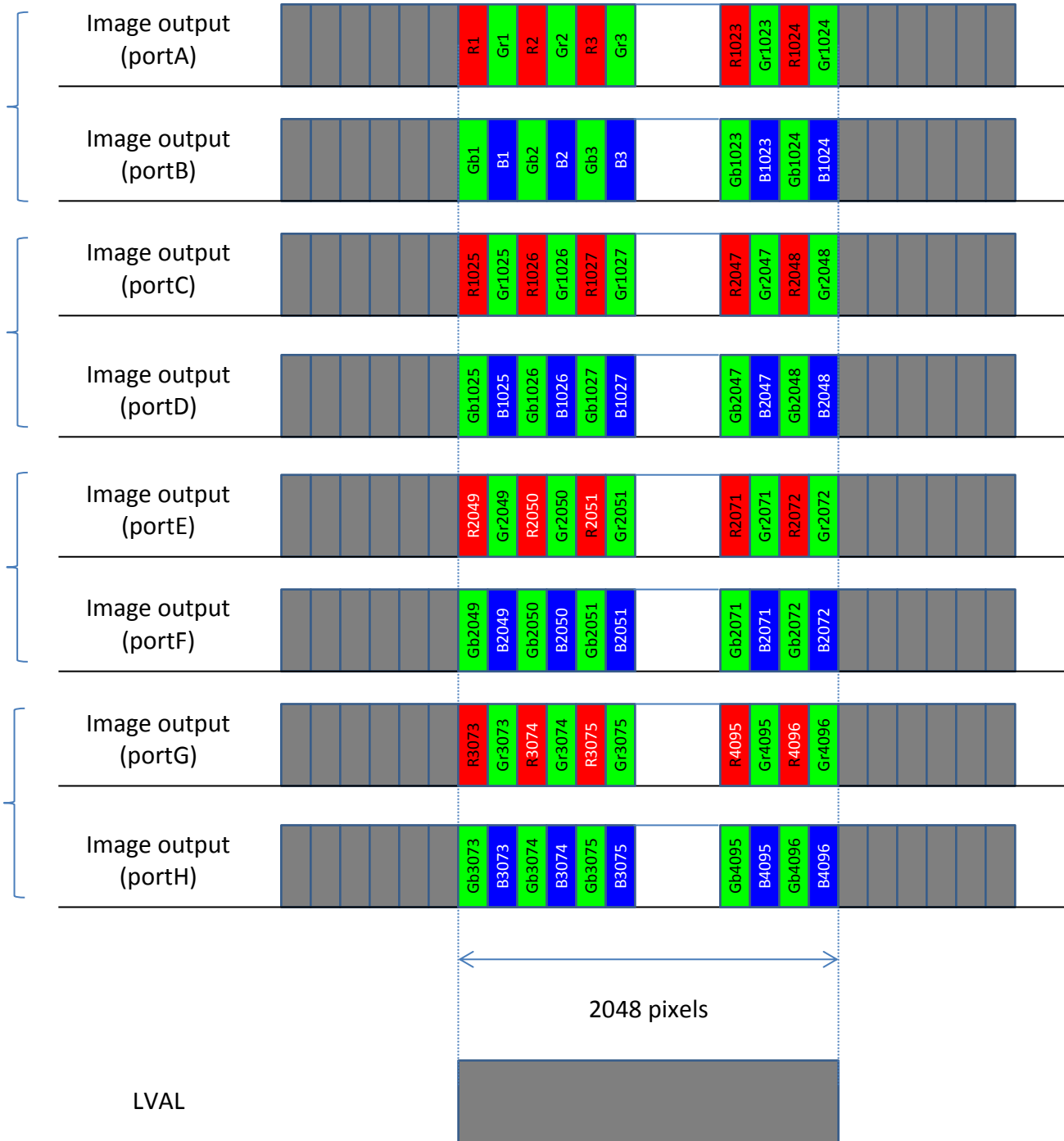

## 11. 8 bit x 4 tap RAW Direct

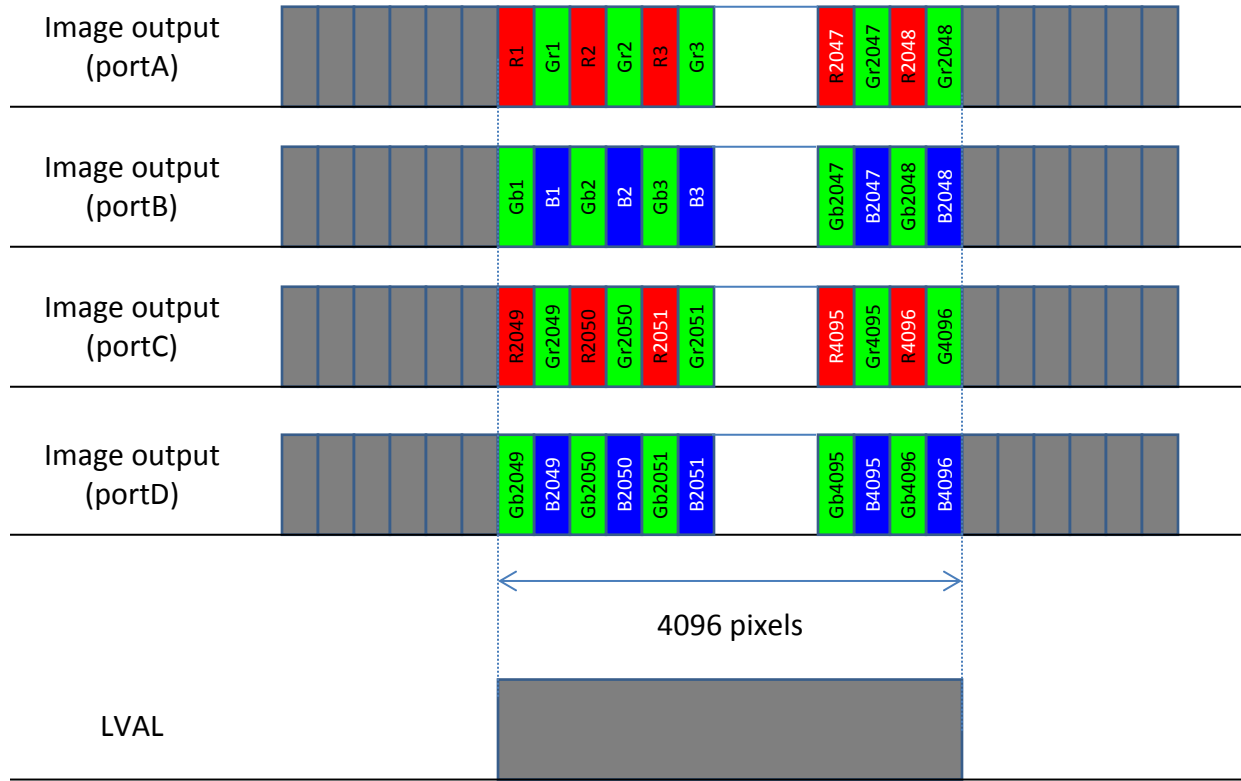

## 12. 10 bit x 4 tap RAW Direct

Follow as per Camera Link Specifications.

### 13. 8 bit x 2 tap RAW Direct

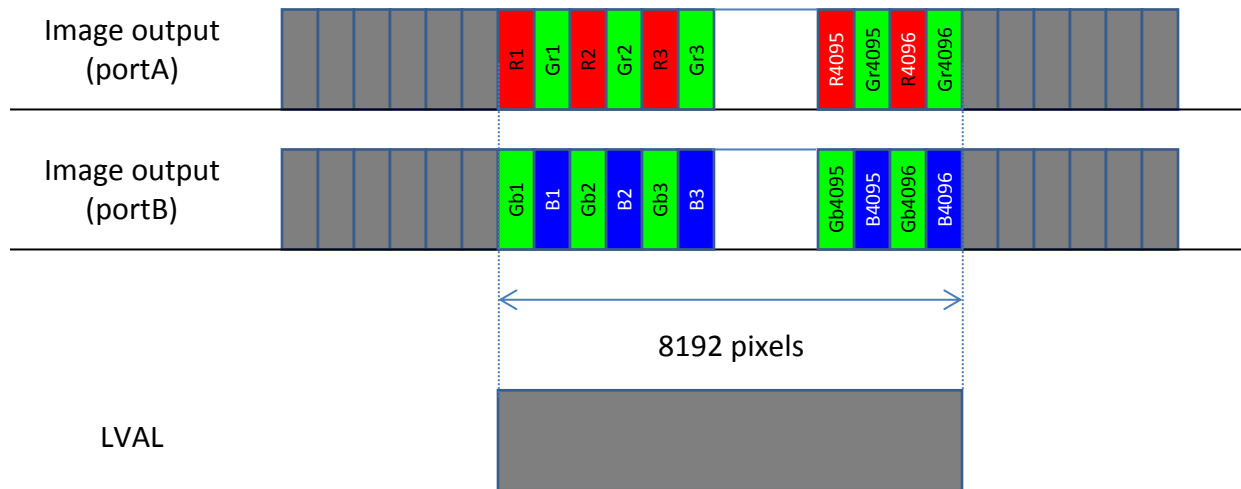

### 14. 10 bit x 2 tap RAW Direct Follow as per Camera Link Specifications.

## 15. 8 bit x 8 tap Raw Dual Line

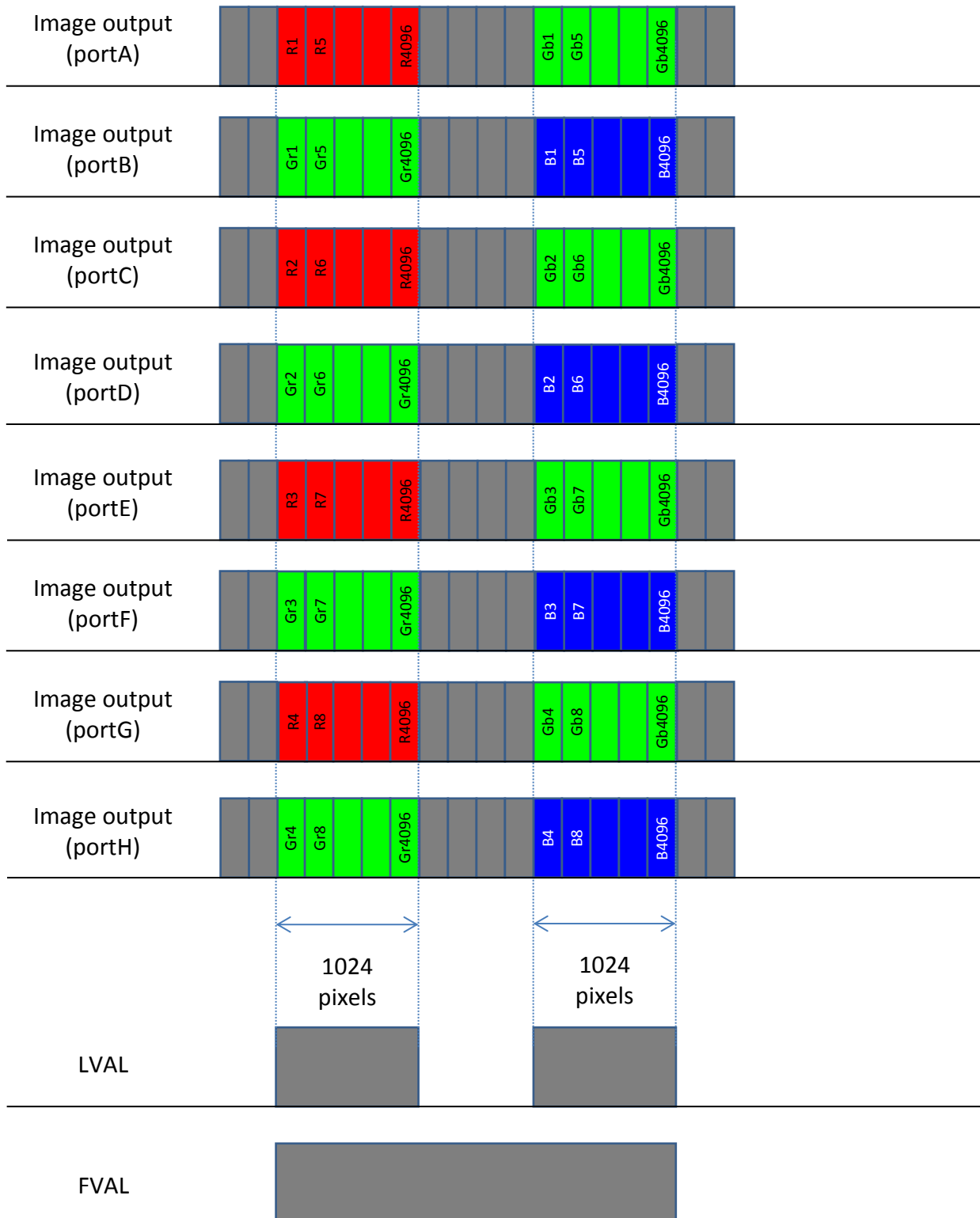

## VII. Communication Specifications

### A. Communication Format

Baud Rate: 9600bps  
Data Length: 8bit  
Start Bit: 1bit  
Stop Bit: 1bit  
Parity: None  
Xon/Xoff Control: None

### B. Communication

Read the setting

Use command to read the settings from the camera.

`usid?<CR>`      To read the camera ID from the camera.

Set the setting

Use this command to set the settings to the camera.

`limd=1<CR>`      To set the external sync system to the camera.

### C. Glossary

[ ]      Omissible  
<CR>    Carriage return

### D. Notes

1. The command name has to be lower-case. Upper-case character is invalid.
2. The command has to be one byte character. Double byte character is invalid.
3. The blank is invalid.
4. The newline code is indicated by "CR(0x0D)".  
    LF(0x0A) and CR+LF are usable for the newline code.  
    However the newline code at the returning command is always as "CR".
5. Retyping the command is necessary in the case of the command input error when use the hyper terminal.

(The command corrects by the cursor moving is invalid)

6. The description of the exceptional case:

\* "NG" is returned in the case of the command input error or input none-exist command.

e.g.: The command input error (Gain A Level number is not designated.)

    Input command:      `ga01=96`  
    Return command:     `NG`

e.g.: When non-exist command input

    Input command:      `ff`  
    Return command:     `NG`

\* "NE" is returned in the case of the numeric value input error.

e.g.: The numeric value input error (Input value is out of the setting range)

Input command: galv=96

Return command: NE

e.g.: The numeric value input error (Input value is out of the setting range)

Input command: ga01=2000

Return command: NE

7. Camera does not accept any command without sync signal. When External Trigger Mode (limd = 1) is used through the Hyper Terminal, please send the command on Internal Sync Mode. And send the next command after receiving OK.

## E. Command List

All commands are in lower-case. The default values are underlined.

	Command Name	Format	Argument	Return value	Explanation
User	Get ID (Note.1)	usid[?]<CR>	N/A	ID ( <u>Default: 0</u> )	Get the camera ID (For multiple camera management)
	Set ID (Note.1)	usid=N<CR>	N: 0-255	OK	Set the camera ID (For multiple camera management)
Sync Selection	Get Sync	limd[?]<CR>	N/A	1: Ext Sync 2: Int Sync	Get the sync system of the camera
	Set Sync	limd=N<CR>	N=1: Ext Sync N=2: Int Sync	OK	Set the sync system of the camera CC1 is the external sync pulse
Exposure control	Get Exposure Control	inmd[?]<CR>	N/A	0: Line cycle 1: Fixed Time Exposure 2: Pulse Width Exposure	Get the exposure control status
	Set Exposure Control	inmd=N<CR>	N=0: Line cycle N=1: Fixed Time Exposure N=2: Pulse Width Exposure	OK	Set the exposure control status
Exposure Time	Get Exposure Time	intu[?]<CR> intl[?]<CR>	N/A	1-255 ( <u>Default: 0</u> ) 0-255 ( <u>Default: 0</u> )	Get the exposure time
	Set Exposure Time	intu=N<CR> intl=N<CR>	N=1-255 N=0-255	OK	Set the exposure time
System	Check	cmck<CR>	N/A	OK	Communication test
	Save	cmsv<CR>	N/A	OK	Save settings to the EEPROM
	Load	cmld<CR>	N/A	OK	Load settings from the EEPROM
	Version	fivr<CR>	N/A	CPU Version	Get the version number of the program for the microcomputer control
	Model	cmmo<CR>	N/A	Model	Get the camera model
	Revision	fpvr<CR>	N/A	FPGA Revision	Get the version number of FPGA
	Initialize	cmin<CR>	N/A	OK	Load the factory settings
	config	cmcf<CR>	N/A	(Data output)	Get the all current settings
	clear	cmcl<CR>	N/A	OK	Clear current command settings of EEPROM
Command list	cmcm<CR>	N/A	command list	active command list	
Data Rate control	Get Data Rate Mode	opck[?]<CR>	N/A	0-255 ( <u>Default: 0</u> )	Get Data Rate Mode
	Set Data Rate Mode	opck=N<CR>	0-255	OK	Set Data Rate Mode
Data	Output bit	opbt=N<CR>	N=8: 8bit N=10: 10bit	OK	Set the video output data width Selectable output is depends on opck mode
		opbt[?]<CR>	N/A	N=8: 8bit N=10: 10bit	

Command Name	Format	Argument	Return value	Explanation
FFC Control Mode	ffmd=N<CR>	N=0: OFF N=1: ON N=2: Data out (Note.2) N=3: Data in (by pixel) N=4: Data in (all) N=5: Auto shade for gain N=6: Auto shade for offset	OK	Shade control mode value reference/setting
	ffmd[?]<CR>	N/A	0: OFF 1: ON 2: Data out (Note.2) 3: Data in (by pixel) 4: Data in (all) 5: Auto shade for gain 6: Auto shade for offset	
Select Gain/Offset	ffgo=N<CR>	N=0: OFF N=1: Gain N=2: Offset	OK	Setting target value reference/setting (Note.3)
	ffgo[?]<CR>	N/A	0: OFF 1: Gain 2: Offset	
Address	ffpl=N<CR>	N: 0-255	OK	address) value reference/setting (Note.4)
	ffpl[?]<CR>	N/A	0-255 (Default: 0)	
Address	ffpu=N<CR>	N: 0-255	OK	address) value reference/setting (Note.4)
	ffpu[?]<CR>	N/A	0-255 (Default: 0)	
FFC Coeff	ffdt=N<CR>	N: 0-255	OK	Set the upper 8bit data of FFC coefficients (12bit).
	ffdtl=N<CR>	N: 16-240	OK	coefficients(12bit) This value has to be a multiple of 16 The remainder of N divided by 16 is ignored
	ffdt[?]<CR>	N/A	0-255 (Default: 0)	Get the upper 8bit data of FFC coefficients (12bit)
	ffdtl[?]<CR>	N/A	16-240 (Default: 16)	coefficients(12bit). This value is multiple of 16
Black Level Target	ffto=N<CR>	N: 0-255	OK	Correction target level value reference/setting for black level (Note.4)
	ffto[?]<CR>	N/A	0-255 (Default: 3)	
Gray Level Target	fftg=N<CR>	N: 0-255	OK	Correction target level value reference/setting for gray level (Note.4)
	fftg[?]<CR>	N/A	0-255 (Default: 200)	
Set Data	ffds<CR>	N/A	OK	Set data
Get Selected Output	fful<CR>	N/A	0: upper 8 bits 1: lower 4 bits	Select upper 8 bits or lower 4 bits of the shade correction value to be put on the video ouput line when ffmd=4
Set Selected Output	fful=N<CR>	0: upper 8 bits 1: lower 4 bits	OK	
EEPROM Load From User Bank	ffld<CR>	N/A	OK	Load shade data (Gain and Offset) from EEPROM user bank
EEPROM Save To user Bank	ffsv<CR>	N/A	OK	Save shade data(Gain and Offset) to EEPROM user bank
EEPROM Load From Factory Bank	fflf<CR>	N/A	OK	Load shade data (Gain and Offset) from EEPROM factory bank
RAM clear	ffcg<CR>	Non	OK	Clear shade data(Gain) to 0
	ffco<CR>	Non	OK	Clear shade data(Offset) to 3200(12bit)

FFC

	Command Name	Format	Argument	Return value	Explanation
FFC	Get User Mode	ffum[?]<CR>	N/A	0:user mode OFF 1:user mode ON	User BANK mode ON/OFF ON: save/load FFC coefficient to User BANK OFF: " Normal BANK
	Set User Mode	ffum=N<CR>	0:user mode OFF 1:user mode ON	OK	
	Get FFC coefficient bank	ffsb[?]<CR>	N/A	0-7 (Default: 0)	Get User BANK
	Set FFC coefficient bank	ffsb=N<CR>	0-7 (Default: 0)	OK	Set User BANK
Test Pattern	Get Test Pattern	tsmd[?]<CR>	N/A	0: OFF 1: test pattern 1 2: test pattern 2 3: test pattern 3	Get test pattern mode
	Set Test Pattern	tsmd=N<CR>	N=0: OFF N=1: test pattern 1 N=2: test pattern 2 N=3: test pattern 3	OK	Set test pattern mode
Digital Gain	Get Gain A Data	gadt<CR>	N/A	0-255 (Default: 0)	Get Digital Gain Data
	Set Gain A Data	gadt=N<CR>	N: 0-255	OK	Set Digital Gain Data
Gain B	Get Gain B Mode	gbdt<CR>	N/A	0 or 1(Default: 0)	Get Gain B Mode
	Set Gain B Mode	gbdt=N<CR>	N=0: OFF N=1: ON	OK	Set Gain B Mode
RGB Digital Gain	Get RGB Digital Gain Mode	gdmd<CR>	N/A	0:RGB GAIN OFF 1:RGB GAIN ON	Get RGB Digital Gain Mode
	Set RGB Digital Gain Mode	gdmd=N<CR>	0:RGB GAIN OFF 1:RGB GAIN ON	OK	Set RGB Digital Gain Mode
	Get Gain Data For R	gddr<CR>	N/A	0-255 (Default: 0)	Get Gain Data For R
	Set Gain Data For R	gddr=N<CR>	N: 0-255	OK	Set Gain Data For R
	Get Gain Data For Gr	gddgr<CR>	N/A	0-255 (Default: 0)	Get Gain Data For Gr
	Set Gain Data For Gr	gddgr=N<CR>	N: 0-255	OK	Set Gain Data For Gr
	Get Gain Data For Gb	gddgb<CR>	N/A	0-255 (Default: 0)	Get Gain Data For Gb
	Set Gain Data For Gb	gddgb=N<CR>	N: 0-255	OK	Set Gain Data For Gb
Anti Blooming Mode	Get Anti Blooming Mode	abmd<CR>	N/A	0 or 1(Default: 0)	Get Anti Blooming Mode
	Set Anti Blooming Mode	abmd=N<CR>	N=0: OFF N=1: ON	OK	Set Anti Blooming Mode
AOI	Get start pixel of AOI	risu<CR>	N/A	0-255 (Default: 0)	Get start pixel of AOI (The upper rank address )
		risl<CR>	N/A	0-255 (Default: 0)	Get start pixel of AOI (The lower rank address )
	Set start pixel of AOI	risu=N<CR>	N=0-255 (Default: 0)	OK	Set start pixel of AOI (The upper rank address )
		risl=N<CR>	N=0-255 (Default: 0)	OK	Set start pixel of AOI (The lower rank address )
	Get the length of LVAL	riwu<CR>	N/A	0-255 (Default: 4)	Get the length of LVAL (The upper rank)
		riwl<CR>	N/A	0-255 (Default: 0)	Get the length of LVAL (The lower rank)
Set the length of LVAL	riwu=N<CR>	N=0-255 (Default: 4)	OK	Set the length of LVAL (The upper rank)	
	riwl=N<CR>	N=0-255 (Default: 0)	OK	Set the length of LVAL (The lower rank)	

Note.1: The camera ID can be saved in the user area of the EEPROM, but cannot be cleared by a clear command.

Note.2: Gain or offset value (coeff) will be put on the video output instead of the image data.

Note.3: Gain or Offset must be set prior to "Set Data".

Note.4: Correction target pixel address =  $ffpu \times 256 + ffpl$ .

## VIII. Command Description

### A. Sync / Exposure Control (limd / inmd)

limd: Change sync control mode.

Inmd: Change exposure control mode.

### B. Sync and Exposure Mode

Four operating mode can be selected using limd in *Sync Selection* and inmd in *Exposure Control*.

		limd	
		1	2
inmd	0	External	Internal
	1	EXT_LINE	Internal
2	EXT_FIX		
		limd	
0	LINE	EXT_LINE	Don't use
1	FIX	EXT_FIX	
2	PLS	Pulse	

#### 1. EXT\_LINE mode

SYNC: External Sync

EXPOSURE TIME: Line Cycle (Refer to 3.1)

$$\text{Exposure time[us]} = \text{Line period} - (2 + (12 \times B))$$

B: CLK period. different by model.

Model	Value [us]
FS-B16KU35CL	0.0235
Except for FS-B16KU35CL	0.0117

#### 2. EXT\_FIX mode

SYNC: External Sync

EXPOSURE TIME: Programmable with intu and intl (Refer to 3.1)

$$\text{Exposure time[us]} = ((\text{intu} \times 256 + \text{intl}) \times C) + 2$$

C: Amount of change time per step

Model	Value [us]
FS-B16KU35CL	0.4
Except for FS-B16KU35CL	0.2

### 3. INTERNAL mode

SYNC: Internal Sync Only

EXPOSURE TIME: Line Cycle (Refer to 3.1)

$$\text{Exposure time[us]} = ( ( \text{intu} \times 256 + \text{intl} ) \times C ) + A - ( 2 + ( 12 \times B ) )$$

$$\text{Line period [us]} = ( ( \text{intu} \times 256 + \text{intl} ) \times C ) + A$$

A : Minimum line period. different depending on the model.

opck	FS-C2KU7DCL	FS-C4KU7DCL	FS-C8KU7DCL
0	13.2 us	13.2 us	13.2 us
1	21.1 us	21.1 us	21.1 us
2	-	24.5 us	24.5 us
3	-	41.6 us	41.6 us
8	13.2us	13.2 us	13.2 us
9	-	26.0 us	26.0 us
11	12.5 us	12.5 us	12.5 us
13	24.5 us	24.5 us	24.5 us
14	41.5 us	41.5 us	41.5 us
15		48.6	48.6 us
16		82.6	82.6 us
21	26.0 us	-	-

B: CLK period. different by model.

C: Amount of change time per step

### 4. PULSE mode

SYNC: External Sync

EXPOSURE TIME: Pulse Width

$$\text{Exposure time[us]} = \text{Pulse width of CC1(High)} - 1$$

## C. Exposure Time Setting ( intu / intl)

When the exposure control mode is programmable, set the exposure time. When sync control is Internal, exposure time becomes a Line period, so you can change the Line period of the camera by this setting value "exposure time". The calculation of the exposure time is different from Sync / Exposure control mode, which is described in the Sync / Exposure control section.

intu: Change the upper byte of exposure time. The valid values are 0-255.

intl: Change the lower byte of exposure time. The valid values are 0-255.

The setting value of exposure time = (intu x 256) +intl

## D. Data Rate Control (opck)

opck;

Change the Camera Link clock speed and the Camera Link output format (Full / Medium / Base). The number and variation of active mods depends on the camera model. See each model's active modes in the following list.

## E. Digital Gain Control (gadt)

gadt :

Set the digital gain.

The possible values are 0-255.

The maximum magnification is four times the gain (in gadt = 255)

This is a function of the FPGA.

Digital gain formula is the following.

$$Yw' = ( 1 + gadt / 64 ) \times ( Yw - ffto ) + ffto$$

Yw': Level after the digital gain

Yw: Level before the digital gain

ffto: "Offset" target level of FFC

## F. RGB Digital Gain (gddr, gddb, gddgr, gddgb)

Digital Gain can be done for each R,Gr,Gb,B. Formulas are as below.

$$Yw\_R' = (1 + gddr / 64) * ( Yw\_R - ffto ) + ffto$$

$$Yw\_B' = (1 + gddb / 64) * ( Yw\_B - ffto ) + ffto$$

$$Yw\_Gr' = (1 + gddgr / 64) * ( Yw\_Gr - ffto ) + ffto$$

$$Yw\_Gb' = (1 + gddgb / 64) * ( Yw\_Gb - ffto ) + ffto$$

Yw\_R', Yw\_B', Yw\_Gr', Yw\_Gb': Level after the digital gain

Yw\_R, Yw\_B, Yw\_Gr, Yw\_Gb: Level before the digital gain

ffto: "Offset" target level of FFC

These formulas are based on working with Flat Field Correction (FFC) and clamping with target level (ffto) in covered.

RGB Digital Gain can be selected by command "gdmd" ON/OFF.

gdmd=0: RGB Digital gain OFF

gdmd=1: RGB Digital Gain ON

## G. Analog Gain Control (gbdt)

gbdt:

Sets the analog gain.

On: 4-fold

Off: 1-fold

This is a function of the CMOS sensor. The value will be sent to the corresponding CMOS sensor register.

## H. Output Bit Setting (opbt)

opbt:

Sets width of video output.

8: 8bit

10: 10bit

## I. Check Communication Establishment

cmck :

Check that the RS232C communication is running.

If you have received the return command "OK", RS232C communication is working.

## J. Save / Load / Clear Camera Setting (cmsv / cml d / cmcl)

cmsv : The "CPU RAM" settings stored in the user area of the "CPU EEPROM".

cml d : Load the "CPU EEPROM" settings of the user area into the "CPU RAM".

cmcl : Reset the user area of the "CPU EEPROM". "CPU RAM" is set to the factory.

## K. Viewing the "Model" and "Firm / FPGA Version" (cmmo / fivr / fpvr)

cmmo : You can get the model number of the camera that is connected now.

Model number	Product number
37	FS-B2KU7CL
39	FS-B4KU35CL
36	FS-B4KU7CL
35	FS-B8KU35CL
34	FS-B8KU7CL
33	FS-B16KU35CL

fivr : You can get the CPU version of the camera that is connected now.

fpvr : You can get the FPGA version of the camera that is connected now.

## L. Viewing Active Commands (Hyper Terminal Only) (cmcm)

cmcm :

List of active commands will be displayed on the HyperTerminal.

Please use only when you communicate with HyperTerminal.

Inspection software commands will not be displayed.

## M. Viewing Camera Settings (Hyper Terminal Only) (cmcf)

cmcf :

List of all setting will be displayed in HyperTerminal.  
Please use only when you communicate with HyperTerminal.  
Inspection software commands will not be displayed.

## N. Flat Field Correction (FFC)

Shade Correction is used for correcting non-uniformity of image brightness resulting from the lens or the imager.

**In using this camera, Shade Correction should be used because the imager has fixed pattern noise.**

**In addition, default setting of shade correction is ON (ffmd=1)**

**When we ship this camera, we save shade coefficients in ROM.**

**The coefficients are automatically loaded at power on.**

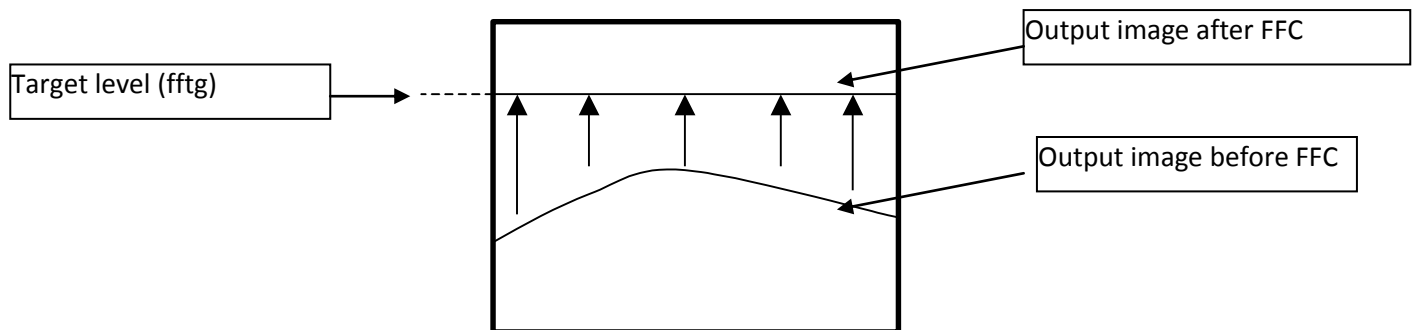

### 1) Auto Shade Correction Procedure

- ffto=A      Set target level to A in a light-shielding condition (8 bit).
- ffmd=6      Correct offset level of each pixel in a light-shielding condition in order to make a flat line.  
(Offset correction value will be calculated only once when *ffmd* is set to 6 from other value.)
- fftg=B      Set target level to B in a light-receiving condition (8 bit).  
(The light brightness level must be lower than the target level.)
- ffmd=5      Correct offset level of each pixel in a light-receiving condition in order to make a flat line.  
(Gain correction value will be calculated only once when *ffmd* is set to 5 from other value.)
- ffmd=1      Comfirm

### 2) Manual Shade Correction Procedure (by pixel)

- ffgo=Y      Select gain or offset correction value.  
1: Gain Correction Value 2: Offset Correction Value
- ffdtu=C      Set correction value.
- ffdtl=D      value =  $D \times 256 + C$
- ffmd=4      Set correction mode to "all pixels".
- ffds          Apply
- ffmd=1      Comfirm

### 3) Manual Shade Correction Procedure (all pixels)

ffgo=Y	Select gain or offset correction value. 1: Gain Correction Value 2: Offset Correction Value
ffpl=A ffpu=B	Set a pixel address. addr = B x 256 + A
ffdtu=C ffdtl=D	Set correction value. value = D x 256 + C
ffmd=3	Set correction mode to "by pixel".
ffds	Apply
ffmd=1	Confirm

### O. Save Correction Value (FFC)

ffsv:

Save correction value of FFC(Gain and Offset). Transfer from RAM to EEPROM.  
(For more information, please refer to the Outline on the camera memories-related FFC)

### P. Load Correction Value (FFC)

ffld:

Load correction value of FFC(Gain and Offset). Transfer from EEPROM to RAM.  
(For more information, please refer to the Outline on the camera memories-related FFC)

### Q. Clear FFC RAM (FFC)

If you want to clear the RAM of only one of the offset or gain, use this command.

ffcg : Clear "FFC RAM" of gain.

ffco : Clear "FFC RAM" of offset.

### R. Anti-Blooming Setting (abmd)

abmd:

Sets Anti-blooming ON/OFF.  
0: OFF  
1: ON

This is a function of the CMOS sensor. You have sent a registry to CMOS sensor.

## S. User ID (usid)

### usid:

When using multiple cameras, you can set the ID for each camera. The camera ID can be saved by a save command(cmsv) in the user area of the “CPU EEPROM”, but cannot be cleared by a clear command(cmcl). The possible values is 0-255.

## T. Digital Gain (gadt)

This gadt can be set the Digital Gain. This Digital Gain formula is the following.

$$Yw' = (1 + gadt / 64) \times (Yw - ffto) + ffto$$

Yw': Level after the digital gain  
Yw : Level before the digital gain  
ffto: “Offset” target level of FFC

These formulas are based on working with Flat Field Correction (FFC) and clamping with target level (ffto) in covered.

## U. RGB Digital Gain (gddr, gddb, gddgr, gddgb)

Digital Gain can be done for each R,Gr,Gb,B. Formulas are as below.

$$Yw\_R' = (1 + gddr / 64) \times (Yw\_R - ffto) + ffto$$

$$Yw\_B' = (1 + gddb / 64) \times (Yw\_B - ffto) + ffto$$

$$Yw\_Gr' = (1 + gddgr / 64) \times (Yw\_Gr - ffto) + ffto$$

$$Yw\_Gb' = (1 + gddgb / 64) \times (Yw\_Gb - ffto) + ffto$$

Yw\_R', Yw\_B' , Yw\_Gr', Yw\_Gb': Level after the digital gain  
Yw\_R, Yw\_B , Yw\_Gr, Yw\_Gb: Level before the digital gain  
ffto: “Offset” target level of FFC

These formulas are based on working with Flat Field Correction (FFC) and clamping with target level (ffto) in covered.

RGB Digital Gain can be selected by command “gdmd” ON/OFF.

gdmd=0: RGB Digital gain OFF

gdmd=1: RGB Digital Gain ON

## V. Area of Interest

AOI is the function that allows the user to output only a portion of the line.

## W. Size of AOI

Size of AOI (width of LVAL) can be set on riwu,riwl commands. These commands are 8bit each, size of AOI is 16 bit data. riwu is MSB 8bit, riwl is LSB 8bit. When user input the values, decimal date should be set.

e.g.

If size of AOI should be set 1000, the value of riwu and riwl should be set the values as follow. 1000 is "0000 0011 1110 1000" on binary. Therefore these values should be set.

riwu=3

riwl=232

3(decimal)= 0000 0011(binary)

232(decimal)= 1110 1000(binary)

The width of LVAL should be shorter than line rate.

If the width of LVAL set longer than line rate, camera does not output the image.

## X. Start Pixel of AOI

The Start Pixel of AOI can be set through risu, risl command, (N is short for Start Pixel N).

Model	Start Pixel
	AOI RGB (Virtual Pixel)
FS-C2KU7CL	$N = \text{risu} * 256 + \text{risl} + 1$

Model	Start Pixel	
	AOI RGB(Virtual Pixel) / AOI RAW Direct / AOI RAW Color	RAW Dual Line
FS-C4KU7CL	$N = \text{risu} * 256 + \text{risl} + 1$	$N = (\text{risu} * 256 + \text{risl}) * 8 + 1$
FS-C8KU7CL	$N = \text{risu} * 256 + \text{risl} + 1$	$N = (\text{risu} * 256 + \text{risl}) * 8 + 1$

e.g. The formula of AOI

mode (Full) of FS-B16KU35CL

$$N = (\text{risu} * 256 + \text{risl}) * 8 + 1$$

can be modified as below

$$(\text{risu} * 256 + \text{risl}) = (N - 1) / 8$$

Therefore, the value of risu,risl can be figured.

- ① Determine the Start pixel N.
- ② Calculate (N-1)/8
- ③ 16bit binary data divide risu(MSB 8bit) and risl(LSB8bit).

e.g.

Start Pixel :801

$$(\text{risu} * 256 + \text{risl}) = 100$$

100(decimal)=0000 0000 0110 0100(binary)

risu=0

risl=100

## IX. Others

### A. Outline on the Camera Memories-Related CPU

There are several non-volatile (EEPROM) and volatile (RAM) memories loaded in a camera. See the block diagram below. This section describes the memory related CPU.

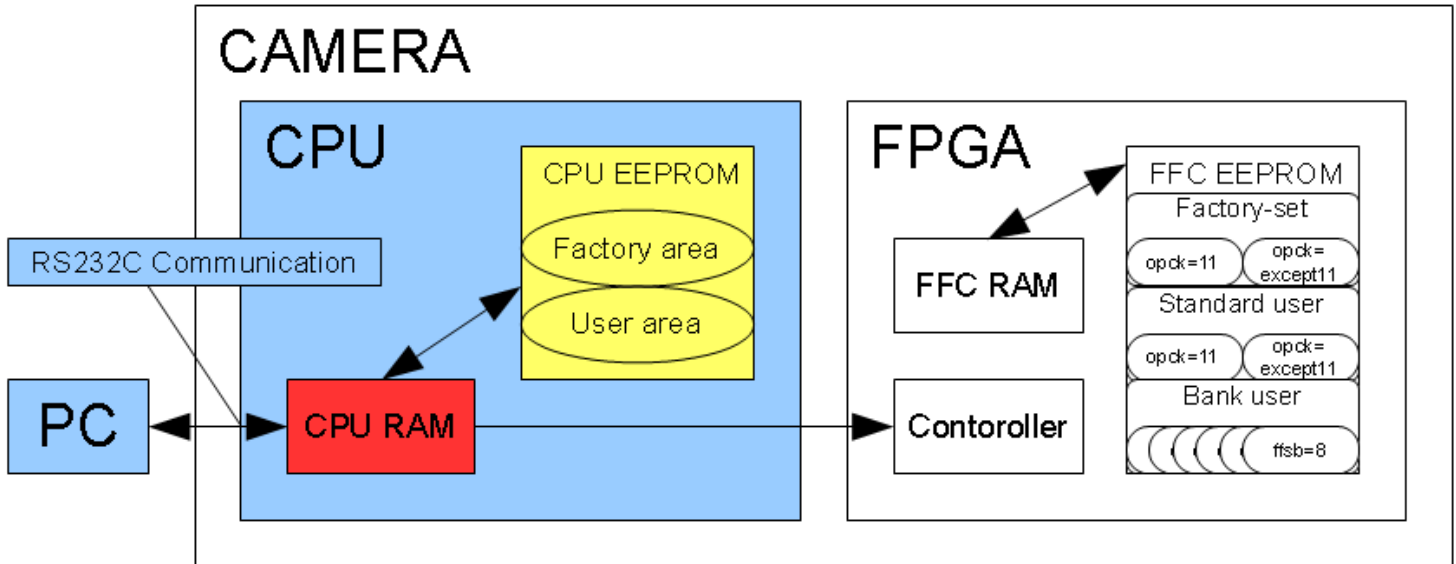

#### 1. CPU RAM

This setting sent via RS232C communication is stored in the "CPU RAM". If a user wants to use the settings of the "CPU RAM" later, please save the data of "CPU RAM" into "CPU EEPROM" before the power is turned off.

#### 2. CPU EEPROM

"CPU EEPROM" is divided into two separate areas: "User area" and "Factory area"

*Factory Area:*

Factory setting data is stored here. This is read only, and cannot be accessed directly by the user.

*User Area:*

User setting data is stored here. Can be accessed with the commands; cmsv / cml. d.

#### 3. Setting Factory Default

If a user wants to set the "CPU RAM" settings to the factory default, please send the Clear command (cmcl). The *User Area* of the "CPU EEPROM" is reset when the Clear command (cmcl) is sent, then the factory settings will be loaded into "CPU RAM".

#### 4. Behavior of Power

When the power is turned on, Factory Default settings are loaded into the "CPU RAM" first. User settings will be loaded afterwards. Therefore, if nothing is saved in the user settings, "CPU RAM" is set to the factory default.

## B. Outline of the Camera Memories-Related CPU

There are several non-volatile (EEPROM) and volatile (RAM) memories loaded in a camera. Please see the block diagram below. The following section describes the memory related FFC.

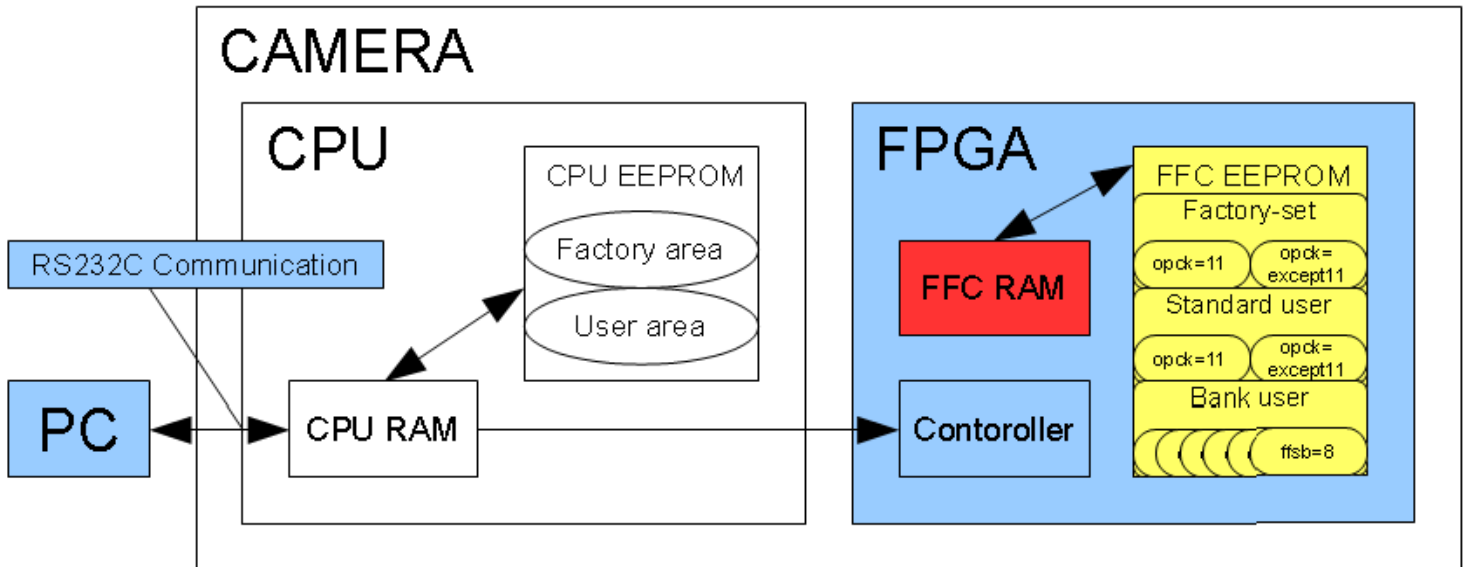

### 1. FFC RAM

"FFC RAM" is for storing a correction data of the Offset and Gain of FFC. When you transfer data between "FFC RAM" and "FFC EEPROM", the data of Gain and Offset is 1 set. The FFC will be corrected with the data of "FFC RAM". If a user wants to use the data of "FFC RAM" later, please save the data of "FFC RAM" into "FFC EEPROM" before the power is turned OFF.

### 2. FFC EEPROM

"FFC EEPROM" is divided into three areas: "Standard user", "Bank user", and "Factory-set".

#### Factory-set:

Factory setting data is stored. Read only. Accessible with the command fflf. Area "Factory-set" is divided into two areas: opck=11 and opck = (except 11) as the behavior of the CMOS sensor is different between [opck=11] and [except 11]. When you send "FFC EEPROM" access command (fflf), the accessing area will change depending on the state of the opck automatically.

#### Standard user:

For a single bank user. When ffum = 0, then access to here. Accessible with the command ffsv / fld. Area "Standard user" is divided into two areas: opck=11 and opck = (except 11) as the behavior of the CMOS sensor is different between [opck=11] and [except 11]. When you send "FFC EEPROM" access command ( ffsv / fld ), the accessing area will change depending on the state of the opck automatically.

#### Bank user:

You can store several patterns of correction data. When ffum = 1, then access here. Access command ffsv / fld. Area "Bank user" is divided into eight areas. Area is switched by ffsb command. Note that the areas cannot be switched depending on opck.

### 3. Behavior of Power

When the power is turned on, that will loaded into the "FFC RAM" from a predetermined area of the "FFC EEPROM" by the state of ffum / ffsb / opck.

## X. Test Patterns

### A. FS-C2KU7DCL

Test Pattern 1 (tsmd=1)



Test Pattern 2 (tsmd=2)



Test Pattern 3 (tsmd=3)



Test Pattern 4 (tsmd=4)



B. FS-C4KU7DCL

Test Pattern 1 (tsmd=1)

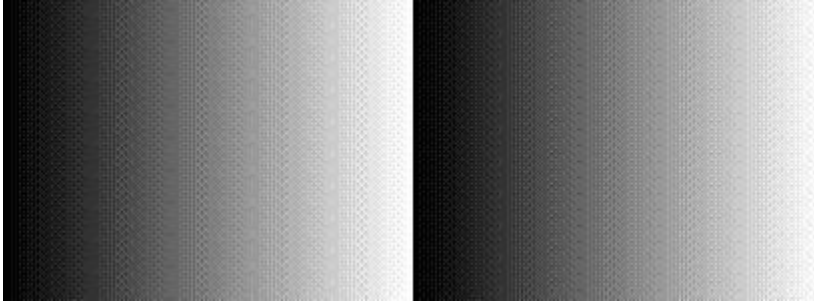

Test Pattern 2 (tsmd=2)

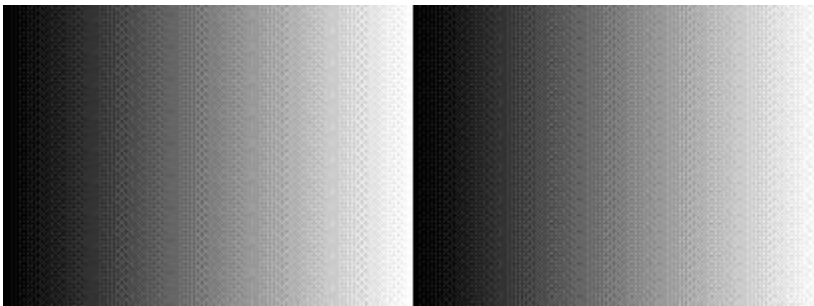

Test Pattern 3 (tsmd=3)

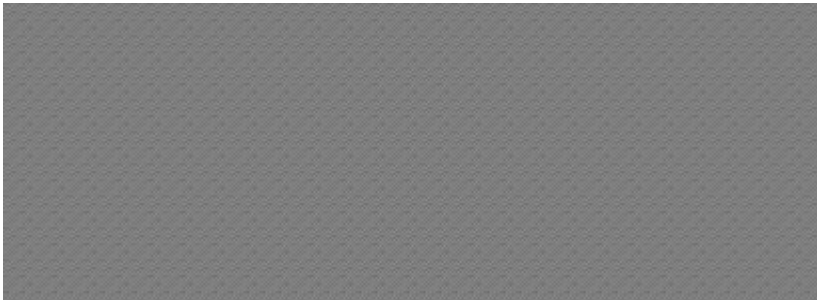

Test Pattern 4 (tsmd=4)

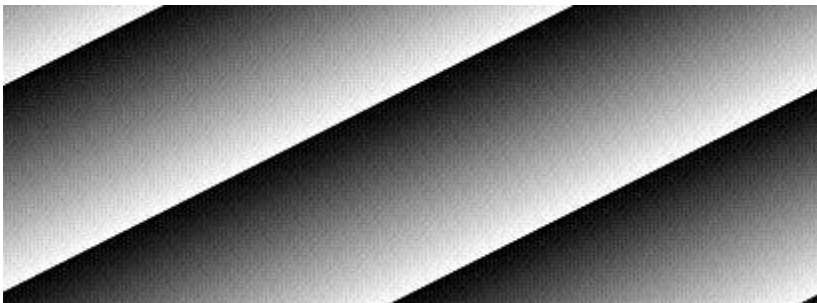

## XI. Quantum Efficiency

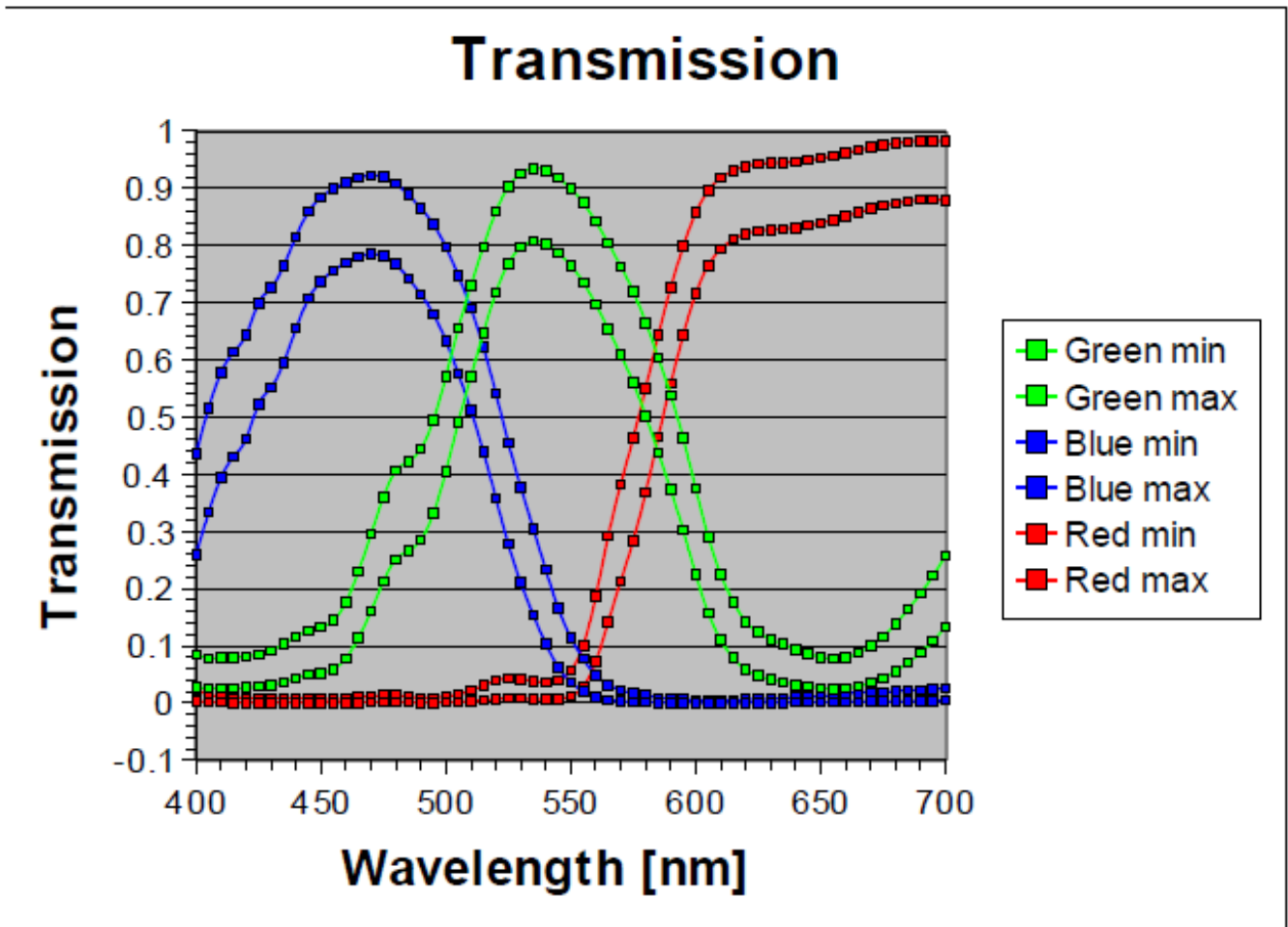

## XII. Dimensions

### A. FS-C2KU7DCL-C

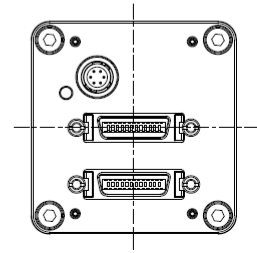
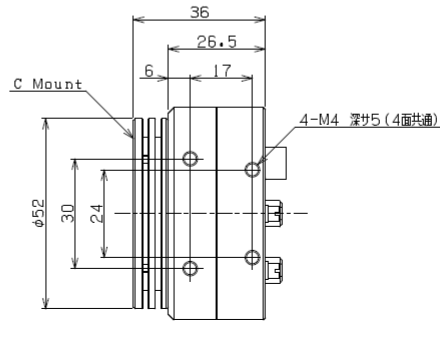
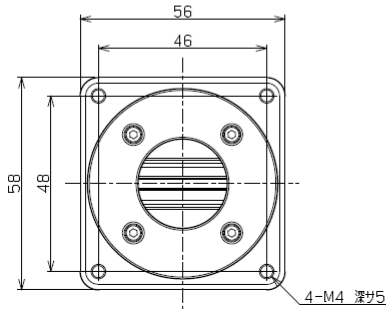
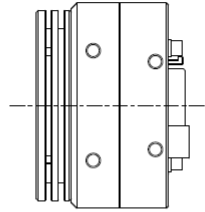
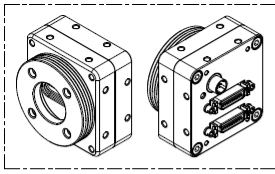

## B. FS-C2KU7DCL-F

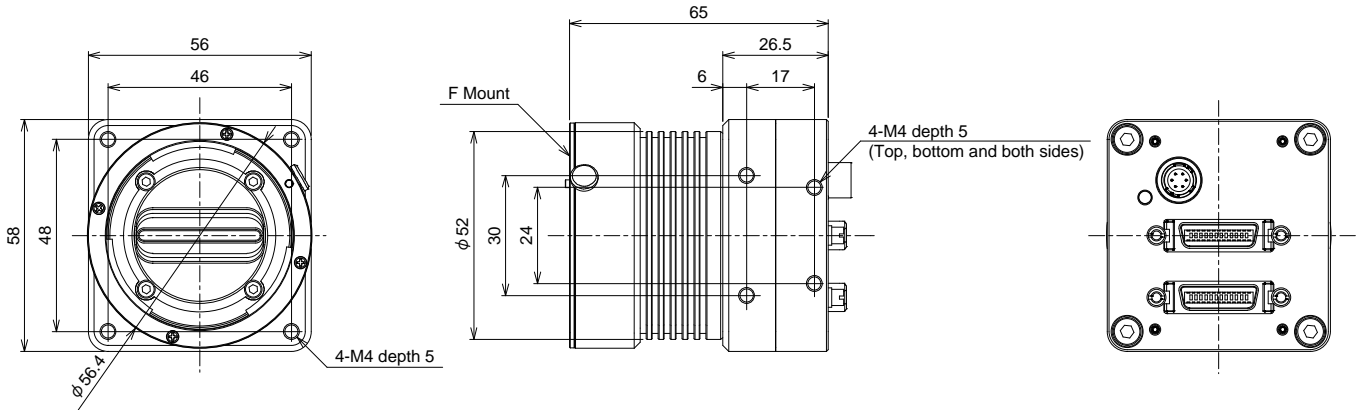
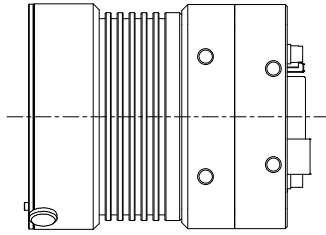
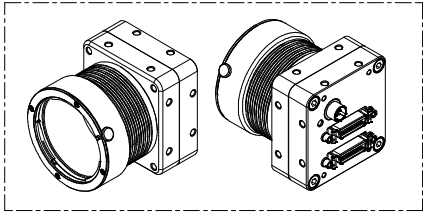

## C. FS-C4KU7DCL-F

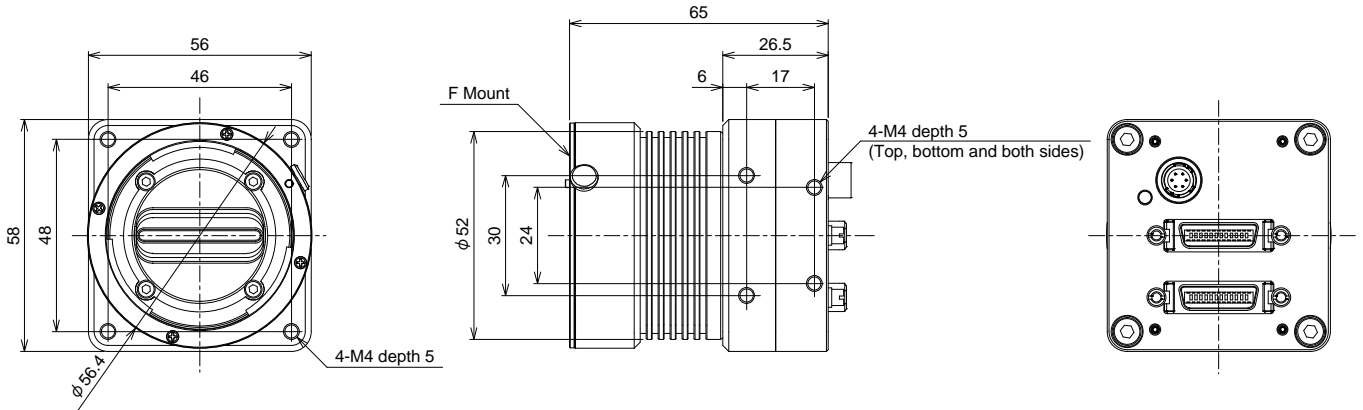
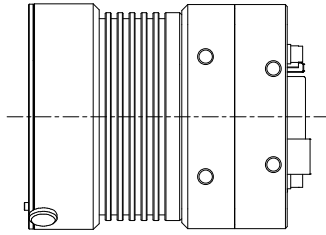
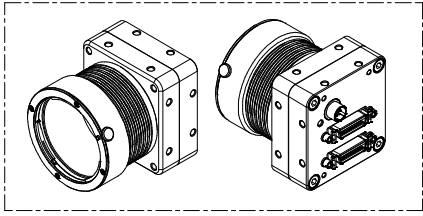

## D. FS-C8KU7DCL-M72

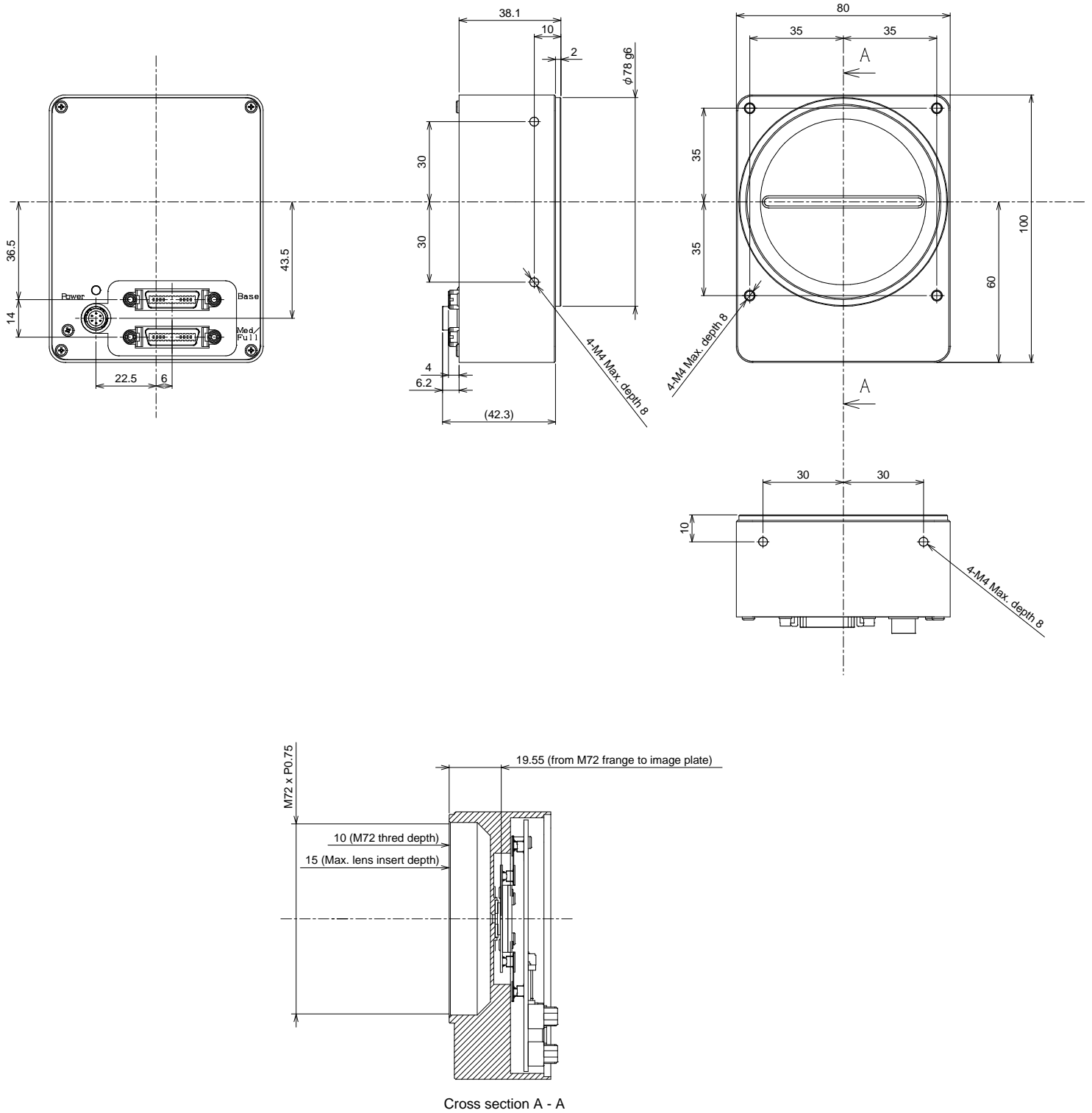

## Revisions

Rev	Date	Change	Notes
1.00	May 29, 2012	New Doc	
1.03	November 27, 2012	Update Added Explanations for Chapters 4,5,6 Revised Timing Charts	
1.04	January 23, 2013	Update	
1.05	April 24, 2013	Edited Version Number	
1.06	August 1, 2013	Update	

**Senor Technologies America, Inc.**

1345 Valwood Parkway, Suite 320  
Carrollton, Texas 75006-6891  
TEL (972)481-9223 FAX(972) 481-9209  
URL <http://www.sentechamerica.com/>

**Sensor Technology Co., Ltd.**

7F, Harada Center Building  
9-17, Naka cho 4 chome  
Atsugi-city, Kanagawa  
243-0018 Japan  
TEL +81-46-295-7061 FAX +81-46-295-7066  
URL <http://www.sentech.co.jp/>

**Taiwan Sensor Technology, Inc.**

3F-6, No. 9, Aiguo W, Rd., Jhong Jheng  
District Taipei City 100, Taiwan, R.O.C.  
TEL 886-2-2383-2331  
FAX 886-2-2370-8775  
EMAIL [sentech0501@yahoo.com.tw](mailto:sentech0501@yahoo.com.tw)