

Overview of SSRs

What Are SSRs?

Difference between SSRs and Mechanical Relays

SSRs (Solid State Relays) have no movable contacts. SSRs are not very different in operation from mechanical relays that have movable contacts. SSRs, however, employ semiconductor switching elements, such as thyristors, triacs, diodes, and transistors. Furthermore, SSRs employ optical semiconductors called photocouplers to isolate input and output signals. Photocouplers change electric signals into optical signals and relay the signals through space, thus fully isolating the input and output sections while relaying the signals at high speed.

SSRs consist of electronic parts with no mechanical contacts. Therefore, SSRs have a variety of features that mechanical relays do not incorporate. The greatest feature of SSRs is that SSRs do not use switching contacts that will physically wear out.

SSRs are ideal for a wide range of applications due to the following performance characteristics.

- They provide high-speed, high-frequency switching operations.
- They have no contact failures.
- They generate little noise.
- They have no operation noise.

Configuration of SSRs

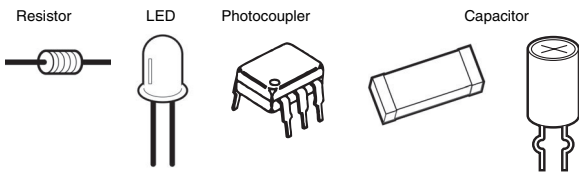
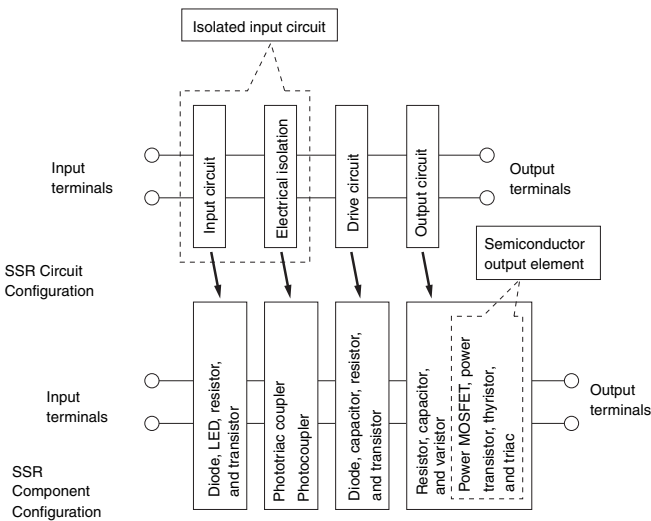

Power transistor (for DC loads)
 Power MOS FET (for AC and DC loads)
 Thyristor (for AC loads)
 Triac (for AC loads)

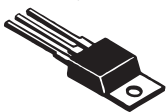

SSRs (Representative Example of Switching for AC Loads)

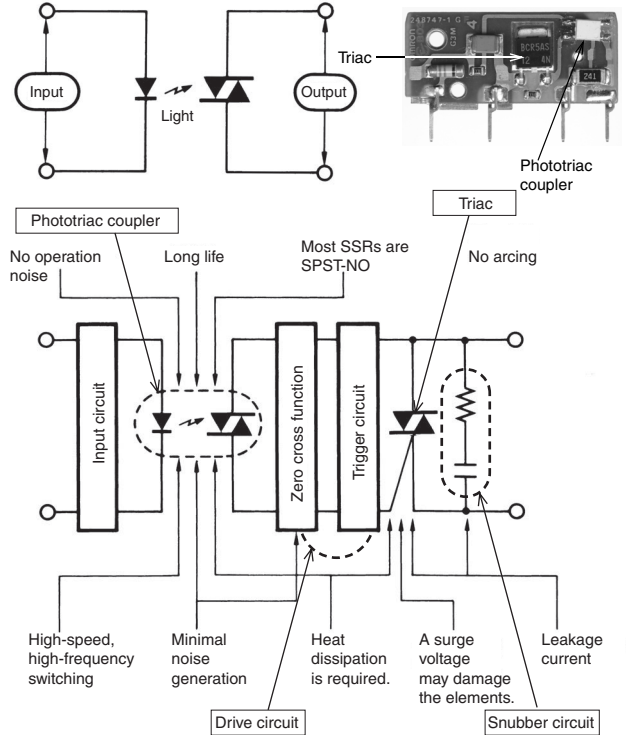

Electromagnetic Relay (EMR)

An EMR generates electromagnetic force when input voltage is applied to the coil. The electromagnetic force moves the armature that switches the contacts in synchronization. EMRs are not only mounted to control panels, but also used for a wide range of applications. The principle of the operation of EMRs is simple and it is possible to manufacture EMRs at low costs.

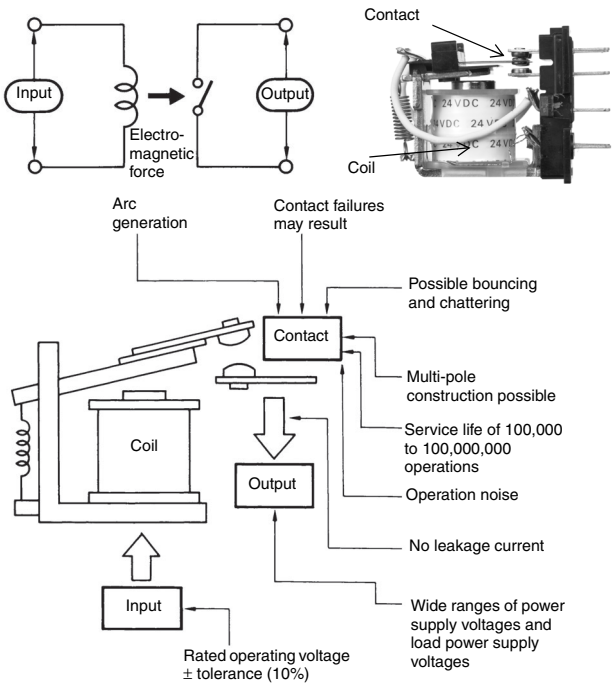

Control of SSRs (ON/OFF Control, Cycle Control, Optimum Cycle Control, Phase Control)

ON/OFF control is a form of control where a heater is turned ON or OFF by turning an SSR ON or OFF in response to voltage output signals from a Temperature Controller. The same kind of control is also possible with an electromagnetic relay but if control where the heater is turned ON and OFF at intervals of a few seconds over a period of several years, then an SSR must be used.

With cycle control (G32A-EA), output voltage is turned ON/OFF at a fixed interval of 0.2 s. Control is performed in response to current output from a Temperature Controller in the range 4 to 20 mA.

The basic principle used for optimum cycle control is zero cross control, which determines the ON/OFF status each half cycle. A waveform that accurately matches the average output time is output. The accuracy of the zero cross function is the same as for

conventionally zero cross control. With conventional zero cross control, however, the output remains ON continuously for a specific period of time, whereas with optimum cycle control, the ON/OFF status is determined each cycle to improve output accuracy.

Precaution for Cycle Control and Optimum Cycle Control

With cycle control, inrush current flows five times every second (because the control cycle is 0.2 s). With a transformer load, the following problems may occur due to the large inrush current (approximately 10 times the rated current), and controlling the power at the transformer primary side may not be possible.

1. The SSR may be destroyed if there is not sufficient leeway in the SSR rating.
2. The breaker on the load circuit may be tripped.

With phase control, output is changed every half-cycle in response to current output signals in the range 4 to 20 mA from a Temperature Controller. Using this form of control, high-precision temperature control is possible, and is used widely with semiconductor equipment.

ON/OFF Control

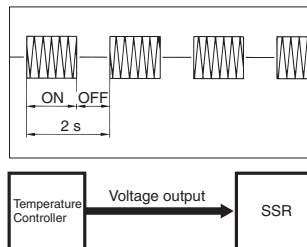

Enables low-cost, noiseless operation without maintenance requirements.

Cycle Control

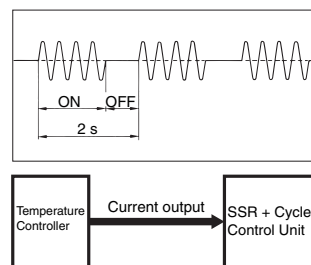

Enables noiseless operation with high-speed response.

Optimum Cycle Control (High-accuracy Zero Cross Control)

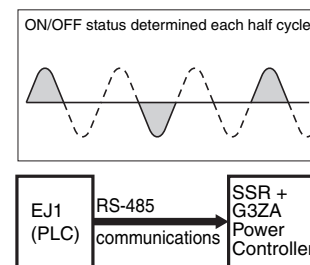

Many heaters can be control using communications. Enables noiseless operation with high-speed response.

Phase Control (Single Phase)

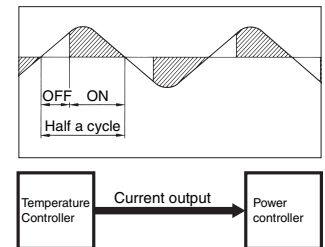

Enables precise temperature control and increases the heater's service life.

Configuration and Operating Principle of MOS FET Relays

MOS FET relays are SSRs that use power MOS FETs in output elements. In order to operate the power MOS FETs, photodiode arrays are used as light-receiving elements. When current flows into the input terminal, the LED lights. This light generates a photoelectromotive force in the photodiode array, and this acts as a gate voltage that turns ON the power MOS FET. By connecting 2 power MOS FETs using a source common, control of AC loads is possible. There are models for control of DC loads, which have just one power MOS FET.

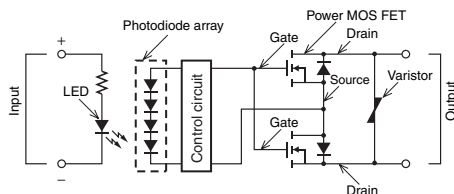

There is no varistor in the G3VM MOS FET relay for signalling.

MOS FET Relay Names

This type of product has a relatively short history, and companies use a variety of names and brands. The following table shows examples for signals (equivalent to the G3VM).

Manufacturer	Name in catalog
Toshiba	Photo Relay
Matsushita Electric Works	Photo MOS Relay
NEC	MOSFET Relay
OKI Electric Industry	Photo MOS Switch
Okita Works	Photo DMOS-FET Relay
HP	Solid-state Relay
OMRON	MOS FET Relay

■ SSR Internal Circuit Configuration Examples

Load specifications	Zero cross function	Isolation	Circuit configuration	Model
AC load	Yes (See note 1.)	Photo-coupler		G3H G3B G3F G3NA (AC input)
	No	Phototriac		G3NE G3J G3F G3H G3TA-OA
	Yes (See note 1.)	Phototriac		G3PA-VD G3PB (single phase) G3NA (DC input) G3NE
	Yes (See note 1.)	Phototriac		G3PB-2(N) (three phases) (See note 2.)
	Yes (See note 1.)	Phototriac		G3PB-3(N) (three phases) (See note 2.)
	Yes (See note 1.)	Photo-coupler		
DC load	---	Photo-coupler		G3FD, G3HD-X03 G3BD G3TA-OD G3NA-D
		Photo-diode coupler		G3HD-202SN
AC/DC load	No	Photo-diode coupler		G3FM

Note: 1. The zero cross function turns ON the SSR when the AC load voltage is 0 V or close to 0 V. SSRs with the zero cross function are effective in the following ways.

- Clicking noise when a load is turned ON is reduced.
- Effects on the power supply are reduced by suppressing inrush current with loads, such as lamps, heaters, and motors, thereby reducing inrush current protection circuits.

2. For 200-V models, use a triac on the output switching elements.

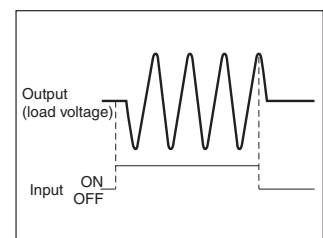

SSR Glossary

Glossary

Terms		Meaning
Circuit functions	Photocoupler	Transfers the input signal while insulating inputs and outputs.
	Phototriac coupler	
	Zero cross circuit (Refer to page 4.)	A circuit which starts operation with the AC load voltage at close to zero-phase.
	Trigger circuit	A circuit for controlling the triac trigger signal, which turns the load current ON and OFF.
	Snubber circuit	A circuit consisting of a resistor R and capacitor C that prevents faulty ignition from occurring in the SSR triac by suppressing a sudden rise in the voltage applied to the triac.
Input	Rated voltage	The voltage that serves as the standard value of an input signal voltage.
	Operating voltage	The permissible voltage range within which the voltage of an input signal voltage may fluctuate.
	Input impedance	The impedance of the input circuit and the resistance of current-limiting resistors used. Impedance varies with the input signal voltage for the constant current input method.
	Must operate voltage	Minimum input voltage when the output status changes from OFF to ON.
	Must release voltage	Maximum input voltage when the output status changes from ON to OFF.
	Input current	The current value when the rated voltage is applied.
Output	Load voltage	The effective supply voltage at which the SSR can be continuously energized with the output terminals connected to a load and power supply in series.
	Maximum load current	The effective value of the maximum current that can continuously flow into the output terminals under specified cooling conditions (such as the size, materials, thickness of the heat sink, and ambient temperature radiating conditions).
	Leakage current	The effective value of the current that can flow into the output terminals when a specified load voltage is applied to the SSR with the output turned OFF.
	Output ON voltage drop	The effective value of the AC voltage that appears across the output terminals when the maximum load current flows through the SSR under specified cooling conditions (such as the size, materials, thickness of heat sink, and ambient temperature radiation conditions).
	Minimum load current	The minimum load current at which the SSR can operate normally.
Characteristics	Operate time	A time lag between the moment a specified signal voltage is imposed to the input terminals and the output is turned ON.
	Release time	A time lag between the moment the imposed signal input is turned OFF and the output is turned OFF.
	Insulation resistance	The resistance between the input and output terminals or I/O terminals and metal housing (heat sink) when DC voltage is imposed.
	Dielectric strength	The effective AC voltage that the SSR can withstand when it is applied between the input terminals and output terminals or I/O terminals and metal housing (heat sink) for more than 1 minute.
	Ambient operating temperature and humidity	The ranges of temperature and humidity in which the SSR can operate normally under specified cooling, input/output voltage, and current conditions.
	Storage temperature	The temperature range in which the SSR can be stored without voltage imposition.
Others	Withstand surge current (See note.)	The maximum non-repeat current that can flow to the SSR. Expressed using the peak value at the commercial frequency in one cycle.
	Counter-electromotive force	Extremely steep voltage rise which occurs when the load is turned ON or OFF.
	Bleeder resistance	The resistance connected in parallel to the load in order to increase apparently small load currents, so that the ON/OFF of minute currents functions normally.

Note: This value was conventionally expressed as the “withstand inrush current”, but has been changed to “withstand surge current” because the former term was easily mistaken for inrush current of loads.

Precautions for Correct Use of SSRs

■ Before Actual Operation

1. The SSR in operation may cause an unexpected accident. Therefore it is necessary to test the SSR under the variety of conditions that are possible. As for the characteristics of the SSR, it is necessary to consider differences in characteristics between individual SSRs.
2. The ratings in this catalog are tested values in a temperature range between 15°C and 30°C, a relative humidity range between 25% and 85%, and an atmospheric pressure range between 88 and 106 kPa. It will be necessary to provide the above conditions as well as the load conditions if the user wants to confirm the ratings of specific SSRs.

■ Input Circuit

Input-side Connection

There is variation in the input impedance of SSRs. Therefore, do not connect multiple inputs in series. Otherwise malfunction may occur.

Input Noise

SSRs need only a small amount of power to operate. This is why the input terminals must shut out electrical noise as much as possible. Noise applied to the input terminals may result in malfunction. The following describes measures to be taken against pulse noise and inductive noise.

1. Pulse Noise

A combination of capacitor and resistor can absorb pulse noise effectively. The following is an example of a noise absorption circuit with capacitor C and resistor R connected to an SSR.

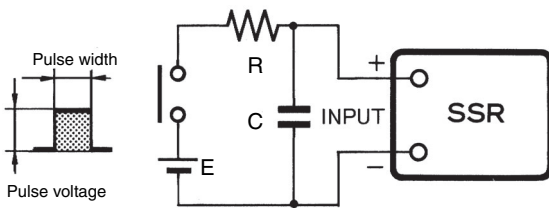

The value of R and C must be decided carefully. The value of R must not be too large or the supply voltage (E) will not be able to satisfy the required input voltage value. The larger the value of C is, the longer the release time will be, due to the time required for C to discharge electricity.

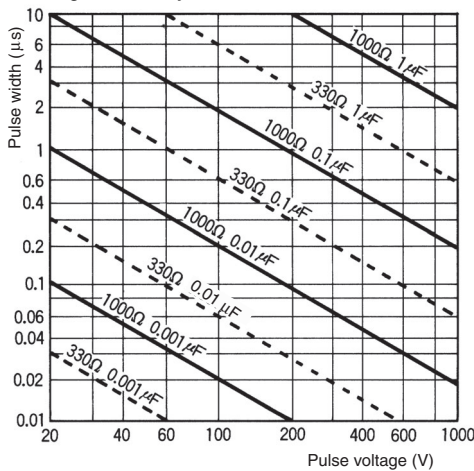

Note: For low-voltage models, sufficient voltage may not be applied to the SSR because of the relationship between C, R, and the internal impedance. When deciding on a value for R, check the input impedance for the SSR.

2. Inductive Noise

Do not wire power lines alongside the input lines. Inductive noise may cause the SSR to malfunction. If inductive noise is imposed on the input terminals of the SSR, use the following cables according to the type of inductive noise, and reduce the noise level to less than the reset voltage of the SSR.

Twisted-pair wires: For electromagnetic noise

Shielded cable: For static noise

A filter consisting of a combination of capacitor and resistor will effectively reduce noise generated from high-frequency equipment.

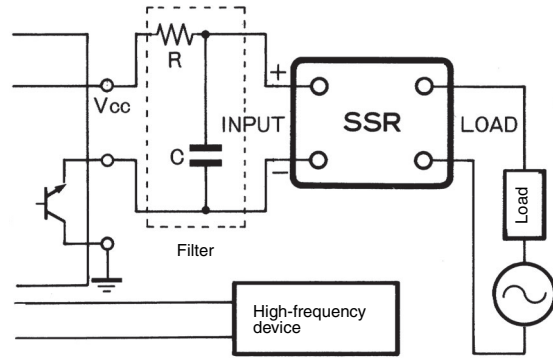

Note: R: 20 to 100 Ω
C: 0.01 to 1 μF

Input Conditions

1. Input Voltage Ripples

When there is a ripple in the input voltage, set so that the peak voltage is lower than the maximum operating voltage and the root voltage is above the minimum operating voltage.

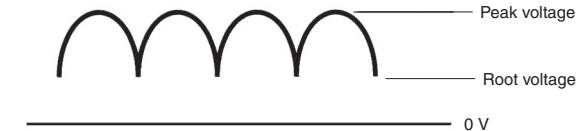

2. Countermeasures for Leakage Current

When the SSR is powered by transistor output, the reset voltage may be insufficient due to leakage current of transistor during power OFF. To counteract this, connect bleeder resistance R as shown in the diagram below and set the resistance so that the voltage applied to both ends of the resistance is less than half of the reset voltage of the SSR.

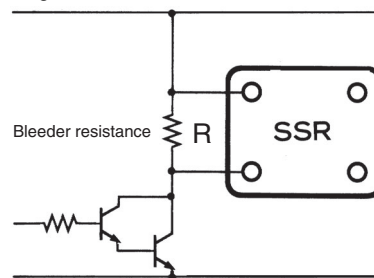

The bleeder resistance R can be obtained in the way shown below.

$$R \leq \frac{E}{I_L - I}$$

E: Voltage applied at both ends of the bleeder resistance = half of the reset voltage of the SSR

I_L: Leakage current of the transistor

I: Reset current of the SSR

The actual value of the reset current is not given in the datasheet and so when calculating the value of the bleeder resistance, use the following formula.

$$\text{Reset current for SSR} = \frac{\text{Minimum value of reset voltage}}{\text{Input impedance}}$$

For SSRs with constant-current input circuits (e.g., G3NA, G3PA, G3PB), calculation is performed at 0.1 mA.

The calculation for the G3M-202P DC24 is shown below as an example.

$$\text{Reset current } I = \frac{1 \text{ V}}{1.6 \text{ k}\Omega} = 0.625 \text{ mA}$$

$$\text{Bleeder resistance } R = \frac{1 \text{ V} \times 1/2}{I_L - 0.625 \text{ mA}}$$

3. ON/OFF Frequency

An SSR has delay times called the operating time and reset time. Loads, such as inductive loads, also have delay times called the operating time and reset time. These delays must all be considered when determining the switching frequency.

4. Input Impedance

In SSRs which have wide input voltages (such as G3F and G3H), the input impedance varies according to the input voltage and changes in the input current. For semiconductor-driven SSRs, changes in voltage can cause malfunction of the semiconductor, so be sure to check the actual device before usage. See the following examples.

Applicable Input Impedance for a Photocoupler-type SSR without Indicators (Example)
G3F, G3H (Without Indicators)

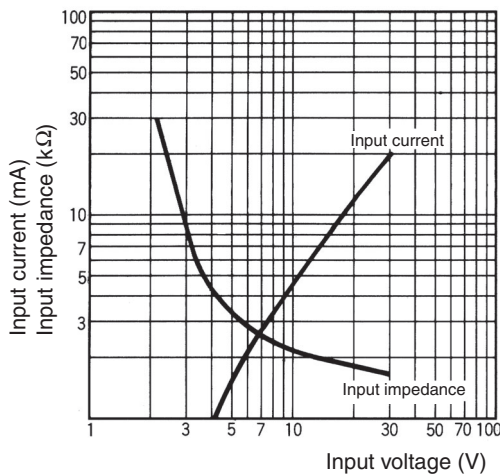

Applicable Input Impedance for a Photocoupler-type SSR with Indicators (Example)
G3B, G3F, G3H (With Indicators)

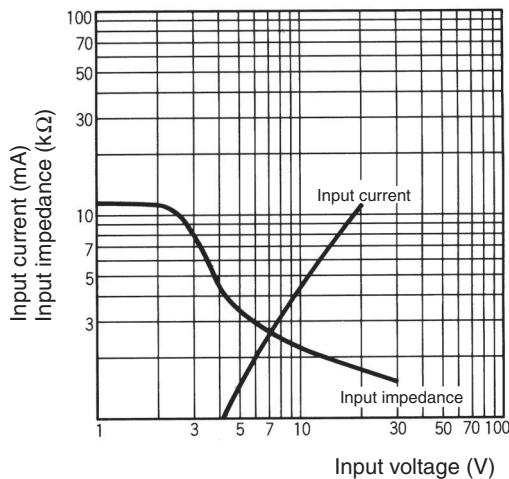

Applicable Input Impedance (Example)
G3CN

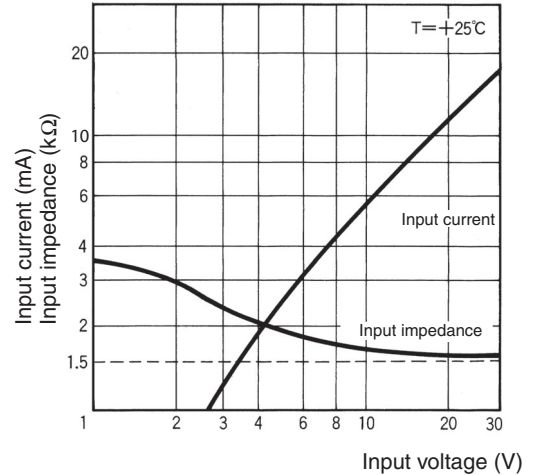

Output Circuit

AC ON/OFF SSR Output Noise Surges

- If there is a large voltage surge in the AC power supply where SSRs are used, the CR snubber circuit built into the SSR between the SSR load terminals will not be sufficient to suppress the surge, and the SSR transient peak element voltage will be exceeded, causing overvoltage damage to the SSR. Varistors should generally be added because measuring surges is often difficult (except when it has been confirmed that there is no surge immediately before use).
- Built-in surge absorption elements are included only with the G3NA, G3S, G3PA, G3PB, G3PC, G3NE, G3J, G3NH, G9H, G3DZ, G3RZ, and G3FM. When switching an inductive load ON and OFF, be sure to take countermeasures against surge, such as adding a surge absorbing element.
- The following is an example of measures in which a surge voltage absorption element has been added. OMRON confirmed the amount of resistance for the SSR output at the following impulse withstand voltage test conditions.
Conditions: Between all I/O terminals and heat sink: 6 kV
Between input terminals and output terminals: 4.5 kV
Between output terminals: 4.5 kV

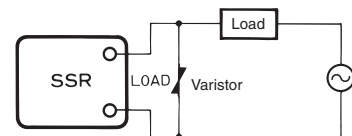

Select an element which meets the conditions in the table below as the surge absorbing element.

Voltage	Varistor voltage	Surge resistance
100 to 120 VAC	240 to 270 V	1,000 A min.
200 to 240 VAC	440 to 470 V	
380 to 480 VAC	820 to 1,000 V	

Output Connections

Do not connect SSR outputs in parallel. With SSRs, both sides of the output will not turn ON at the same time, so the load current cannot be increased by using parallel connections.

DC ON/OFF SSR Output Noise Surges

When an L load, such as a solenoid or electromagnetic valve is connected, connect a diode that prevents counter-electromotive force. If the counter-electromotive force exceeds the withstand voltage of the SSR output element, it could result in damage to the SSR output element. To prevent this, insert the element parallel to the load, as shown in the following diagram and table.

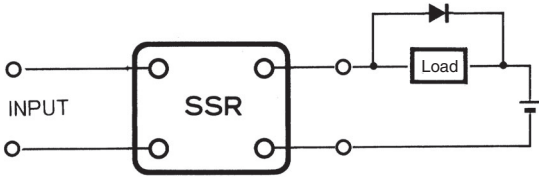

As an absorption element, the diode is the most effective at suppressing the counter-electromotive force. The release time for the solenoid or electromagnetic valve will, however, increase. Be sure to check the circuit before use. To shorten the time, connect a Zener diode and a regular diode in series. The release time will be shortened at the same rate that the Zener voltage (V_z) of the Zener diode is increased.

Table 1. Absorption Element Example

Absorption element				
	Diode	Diode + Zener diode	Varistor	CR
Effectiveness	○	○	△	×

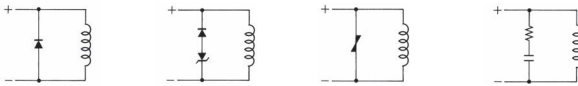

(Reference)

1. Selecting a Diode

Withstand voltage = $V_{RM} \geq$ Power supply voltage \times 2
Forward current = $I_F \geq$ Load current

2. Selecting a Zener Diode

Zener voltage = $V_z < (\text{SSR's connector} - \text{emitter voltage})^* - (\text{Power supply voltage} + 2 \text{ V})$
Zener surge reverse power = $P_{RSM} > V_z \times \text{Load current} \times \text{Safety factor (2 to 3)}$

Note: When the Zener voltage is increased (V_z), the Zener diode capacity (P_{RSM}) is also increased.

AND Circuits with DC Output SSRs

Use the G3DZ or G3RZ for the following type of circuit. Do not use standard SSRs, otherwise the circuit may not be reset

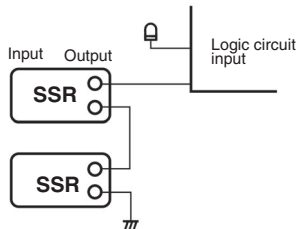

Self-holding Circuits

Self-holding circuits must use mechanical relays. SSRs cannot be used to design self-holding circuits.

Selecting an SSR with Differing Loads

The following provides examples of the inrush currents for different loads.

AC Load and Inrush Current

Load	Solenoid	Incan- descent lamp	Motor	Relay	Capaci- tor	Resis- tance load
Inrush current/ Normal current	Approx. 10 times	Approx. 10 to 15 times	Approx. 5 to 10 times	Approx. 2 to 3 times	Approx. 20 to 50 times	1
Wave- form						

1. Heater Load (Resistive Load)

Load without an inrush current. Generally used together with a voltage-output temperature controller for heater ON/OFF switching. When used with an SSR with zero cross function, suppresses most noise generated. This type of load does not, however, include all-metal and ceramic heaters. Since the resistance values at normal temperatures of all-metal and ceramic heaters are low, an overcurrent will occur in the SSR, causing damage. For switching of all-metal and ceramic heaters, select a Power Controller (G3PX) with a long soft-start time, or a constant-current type SSR.

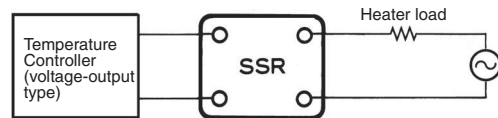

2. Lamp Load

Large inrush current flows through incandescent lamps, halogen lamps, and so on (approx. 10 to 15 times higher than the rated current value). Select an SSR so that the peak value of inrush current does not exceed half the withstand surge current of the SSR. Refer to "Repetitive" (indicated by dashed lines) shown in the following figure. When a repetitive inrush current of greater than half the withstand surge current is applied, the output element of the SSR may be damaged.

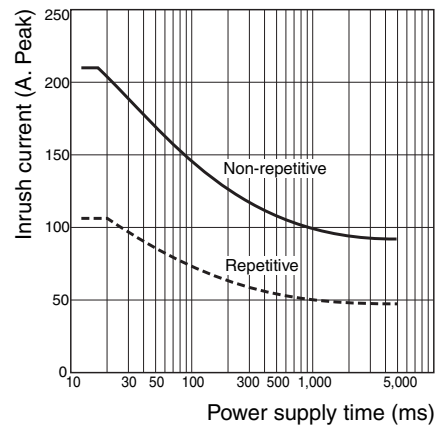

3. Motor Load

When a motor is started, an inrush current of 5 to 10 times the rated current flows and the inrush current flows for a longer time. In addition to measuring the startup time of the motor or the inrush current during use, ensure that the peak value of the inrush current is less than half the withstand surge current when selecting an SSR. The SSR may be damaged by counter-electromotive force from the motor when the SSR is turned OFF. Be sure to install overvoltage protection.

4. Transformer Load

When the SSR is switched ON, an energizing current of 10 to 20 times the rated current flows through the SSR for 10 to 500 ms. If there is no load in the secondary circuit, the energizing current will reach the maximum value. Select an SSR so that the energizing current does not exceed half the withstand surge current of the SSR.

5. Half-wave Rectified Circuit

AC electromagnetic counters and solenoids have built-in diodes, which act as half-wave rectifiers. For these types of loads, a half-wave AC voltage does not reach the SSR output. For SSRs with the zero cross function, this can cause them not to turn ON. Two methods for counteracting this problem are described below. These two methods, however, cannot be used to switch a half-wave rectified break coil. We recommend using an SSR that is designed to switch DC loads.

Refer to *DC ON/OFF SSR Output Noise Surges* on page 8 and implement countermeasures for counter-electromotive force. Application is not possible for 200-VAC half-wave rectified circuits (peak voltage of 283 V)

- (a) Connect a bleeder resistance with approximately 20% of the SSR load current.

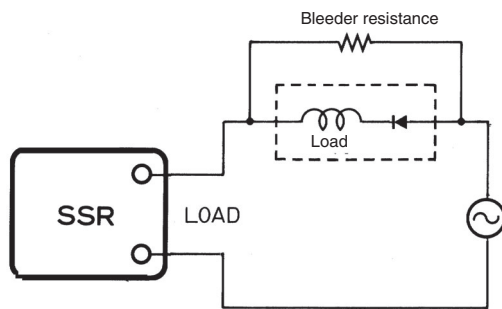

(b) Use SSRs without the zero cross function.

6. Full-wave Rectified Loads

AC electromagnetic counters and solenoids have built-in diodes which act as full-wave rectifiers. The load current for these types of loads has a rectangular wave pattern, as shown in the diagram below.

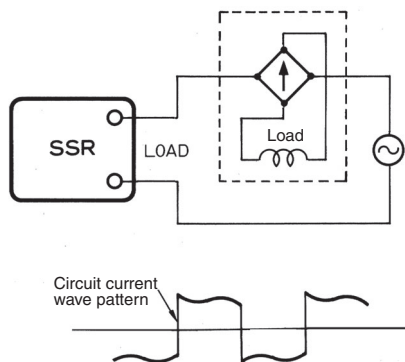

Accordingly, AC SSRs use a triac (which turns OFF the element only when the circuit current is 0 A) in the output element. If the load current waveform is rectangular, it will result in a SSR reset error. When switching ON and OFF a load whose waves are all rectified, use a -V model or Power MOS FET Relay.

-V-model SSRs: G3F-203SL-V, G3H-203SL-V
Power MOS FET Relay: G3DZ, G3RZ, G3FM

7. Small-capacity Loads

Even when there is no input signal to the SSR there is a small leakage current (I_L) from the SSR output (LOAD). If this leakage current is larger than the load release current, the SSR may fail to reset.

Connect the bleeder resistance R in parallel to increase the SSR switching current.

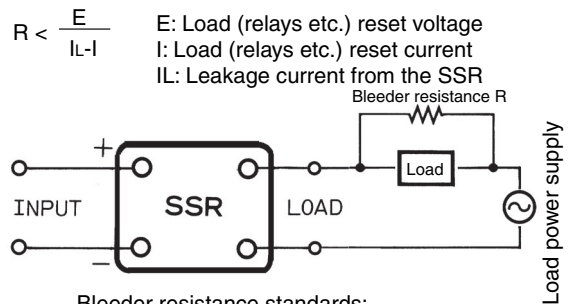

Bleeder resistance standards:
100-VAC power supply, 5 to 10 kΩ, 3 W
200-VAC power supply, 5 to 10 kΩ, 15 W

8. Inverter Load

Do not use an inverter-controlled power supply as the load power supply for the SSR. Inverter-controlled waveforms are rectangular. The extremely large dV/dt may cause the SSR to misfire and prevent it from resetting.

An inverter-controlled power supply may be used on the input side provided the effective voltage is within the normal operating voltage range of the SSR.

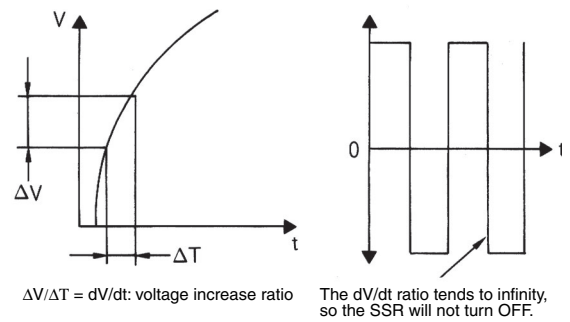

9. Capacitive Load

The supply voltage plus the charge voltage of the capacitor is applied to both ends of the SSR when it is OFF. Therefore, use an SSR model with an input voltage rating twice the size of the supply voltage.

Limit the charge current of the capacitor to less than half the withstand surge current of the SSR.

■ Load Power Supply

1. Rectified Currents

If a DC load power supply is used for full-wave or half-wave rectified AC currents, be sure that the peak load current does not exceed the maximum usage load power supply of the SSR. Otherwise, overvoltage will cause damage to the output element of the SSR.

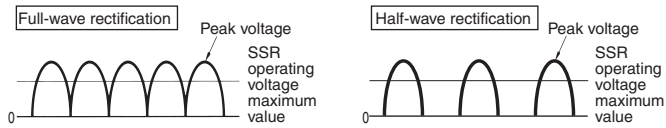

2. Operating Frequency for AC Load Power Supply

The operating frequency range for AC load power supply is 47 to 63 Hz.

3. Low AC Voltage Loads

If the load power supply is used under voltage below the minimum operating load voltage of the SSR, the loss time of the voltage applied to the load will become longer than that of the SSR operating voltage range. See the following load example. (The loss time is $A < B$.)

Make sure that this loss time will not cause problems, before operating the SSR.

If the load voltage falls below the trigger voltage, the SSR will not turn ON, so be sure to set the load voltage to 75 VAC min. (24 VAC for G3PA-VD and G3NA-2□□B.)

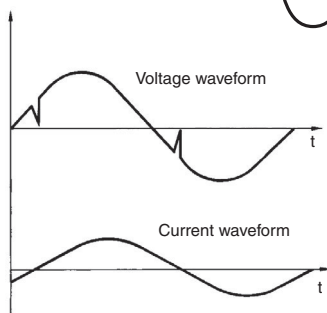
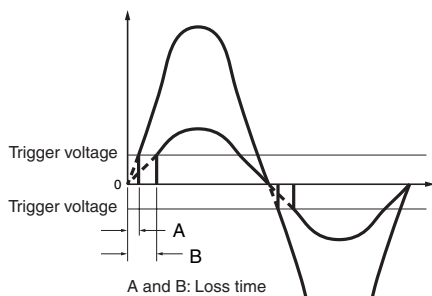

An inductance (L) load causes a current phase delay as shown above. Therefore, the loss is not as great as that caused by a resistive (R) load. This is because a high voltage is already imposed on the SSR when the input current to the SSR drops to zero and the SSR is turned OFF.

4. Phase-controlled AC Power Supplies

Phase-controlled power supply cannot be used.

■ Operation and Storage Environment Precautions

1. Ambient Operating Temperature

The rated value for the ambient operating temperature of the SSR is for when there is no heat build-up. For this reason, under conditions where heat dissipation is not good due to poor ventilation, and where heat may build up easily, the actual temperature of the SSR may exceed the rated value resulting in malfunction or burning.

When using the SSR, design the system to allow heat dissipation sufficient to stay below the Load Current vs. Ambient Temperature characteristic curve. Note also that the ambient temperature of the SSR may increase as a result of environmental conditions (e.g., climate or air-conditioning) and operating conditions (e.g., mounting in an airtight panel).

2. Operation and Storage Locations

Do not use or store the SSR in the following locations. Doing so may result in damage, malfunction, or deterioration of performance characteristics.

- Locations subject to direct sunlight
- Usage in locations subject to ambient temperatures outside the range specified for individual products
- Usage in locations subject to relative humidity outside the range specified for individual products or locations subject to condensation as the result of severe changes in temperature
- Storage in locations subject to ambient temperatures outside the range specified for individual products
- Locations subject to corrosive or flammable gases
- Locations subject to dust (especially iron dust) or salts
- Locations subject to shock or vibration
- Locations subject to exposure to water, oil, or chemicals

3. Extended Storage of the SSR

If the SSR is stored for an extended period of time, the terminal will be exposed to the air, reducing its solderability due to such effects as oxidation. Therefore, when installing a Relay onto a board after a long time in storage, check the state of the solder before use.

4. Vibration and Shock

Do not subject the SSR to excessive vibration or shock. Otherwise the SSR may malfunction or failure to operate may result due to deformation or damage to parts inside the SSR.

To prevent the SSR from abnormal vibration, do not install the Unit in locations or by means that will subject it to the vibrations from other devices, such as motors.

5. Solvents

Do not allow the SSR to come in contact with solvents, such as thinners or gasoline. Doing so will dissolve the markings on the SSR.

6. Oil

Do not allow the SSR terminal cover to come in contact with oil. Doing so will cause the cover to crack and become cloudy.

Working with SSRs

1. Leakage Current

A leakage current flows through a snubber circuit in the SSR even when there is no power input. Therefore, always turn OFF the power to the input or load and check that it is safe before replacing or wiring the SSR.

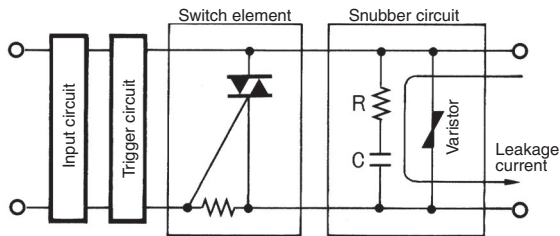

2. Screw Tightening Torque

Tighten the SSR terminal screws properly. If the screws are not tight, the SSR will be damaged by heat generated when the power is ON. Perform wiring using the tightening torque shown in the following table.

SSR Terminal Screw Tightening Torque

SSR model	Screw size	Recommended tightening torque
G3PC, G32A, Sockets, etc.	M3.5	0.78 to 1.18 N·m
G3NA, G3PA-10/20A	M4	0.98 to 1.37 N·m
G3NA, G3PA-40A	M5	1.57 to 2.35 N·m
G3HN-□□75	M6	3.92 to 4.9 N·m
G3HN-□□150	M8	8.82 to 9.8 N·m

Note: Excessive tightening may damage the screws. Tighten screws to within the above ranges.

3. SSR Mounting Panel Quality

If the G3NA, G3NE, or G3PB models with separate heat sinks are to be mounted directly onto the control panel, without the use of a heat sink, be sure to use a panel material with low thermal resistance, such as aluminum. Be sure to apply silicon grease for heat dissipation (e.g., the YG6260 from Toshiba or the G746 from Shin-Etsu) to the mounting surface.

Do not mount the SSR on a panel with high thermal resistance such as a panel coated with paint. Doing so will decrease the radiation efficiency of the SSR, causing heat damage to the SSR output element. Do not mount the SSR on a panel made of wood or any other flammable material. Otherwise the heat generated by the SSR will cause the wood to carbonize, and may cause a fire.

4. Surface-mounting Socket

1. Make sure that the surface-mounting socket screws are tightened securely when mounted. If the Unit is subjected to shock or vibration and the socket mounting screws are loose, the Socket and the SSR, or the lead wires may detach. The surface-mounting Sockets can be snapped on to the 35-mm DIN Track.
2. Use a holding bracket to ensure proper connection between the SSR and Socket. Otherwise the SSR may detach from the socket if an excessive vibration or shock is applied.

5. SSR Mounting and Dismounting

Direction

Mount or dismount the SSR from the Socket perpendicular to the Socket surface. If it is mounted or dismounted with an inclination from the diagonal line, terminals of the SSR may bend and the SSR may not be properly inserted in the Socket.



6. Wiring for Wrapping Terminal Socket

Refer to the following table and conduct wiring properly. Improper wiring may cause the lead wires to detach.

Model	Wrapping type	Model (bit)	Applicable wires		Sheath length to be removed (mm)	Number of effective turns	Standard terminal (mm)	Draw-out force (kg)	Applicable sleeve
			AWG	Dia.					
PY□QN	Single-turn wrapping of sheathed line	21-A	26	0.4	43 to 44	Ap- prox. 6	1 × 1	3 to 8	1-B
		22-A	24	0.5	36 to 37				
		23-A	22	0.65	41 to 42	Ap- prox. 6			
PT□QN	Normal wrapping	20-A	20	0.8	37 to 38	Ap- prox. 4	1.0 × 1.5	5 to 15	

Note: The PY□QN uses a 0.65-mm-dia. wire that can be turned six times.
The PT□QN uses a 0.8-mm-dia. wire that can be turned four times.

7. Tab Terminal Soldering Precautions

Do not solder the lead wires to the tab terminal. Otherwise the SSR (e.g., G3NE) components will be damaged.

8. Cutting Terminals

Do not cut the terminal using an auto-cutter. Cutting the terminal with devices such as an auto-cutter may damage the internal components.

9. Deformed Terminals

Do not attempt to repair or use a terminal that has been deformed. Otherwise excessive force will be applied to the SSR, and it will lose its original performance capabilities.

10. Hold-down Clips

Exercise care when pulling or inserting the hold-down clips so that their form is not distorted. Do not use a clip that has already been deformed. Otherwise excessive force will be applied to the SSR, causing it not to perform to its full capacity, and also it will not have enough holding power, causing the SSR to be loose, and resulting in damage to the contacts.

11. PCB SSR Soldering

- SSRs must be soldered at 260°C within five seconds. For models, however, that conform to separate conditions, perform soldering according to the specified requirements.
- Use a rosin-based non-corrosive flux that is compatible with the material of the SSR.

12. Ultrasonic Cleaning

Do not use ultrasonic cleaning. If the SSR is cleaned using ultrasonic cleaning after it has been mounted to the PCB, resonance due to ultrasonic waves may result in damage to the SSR's internal components.

SSR Troubleshooting

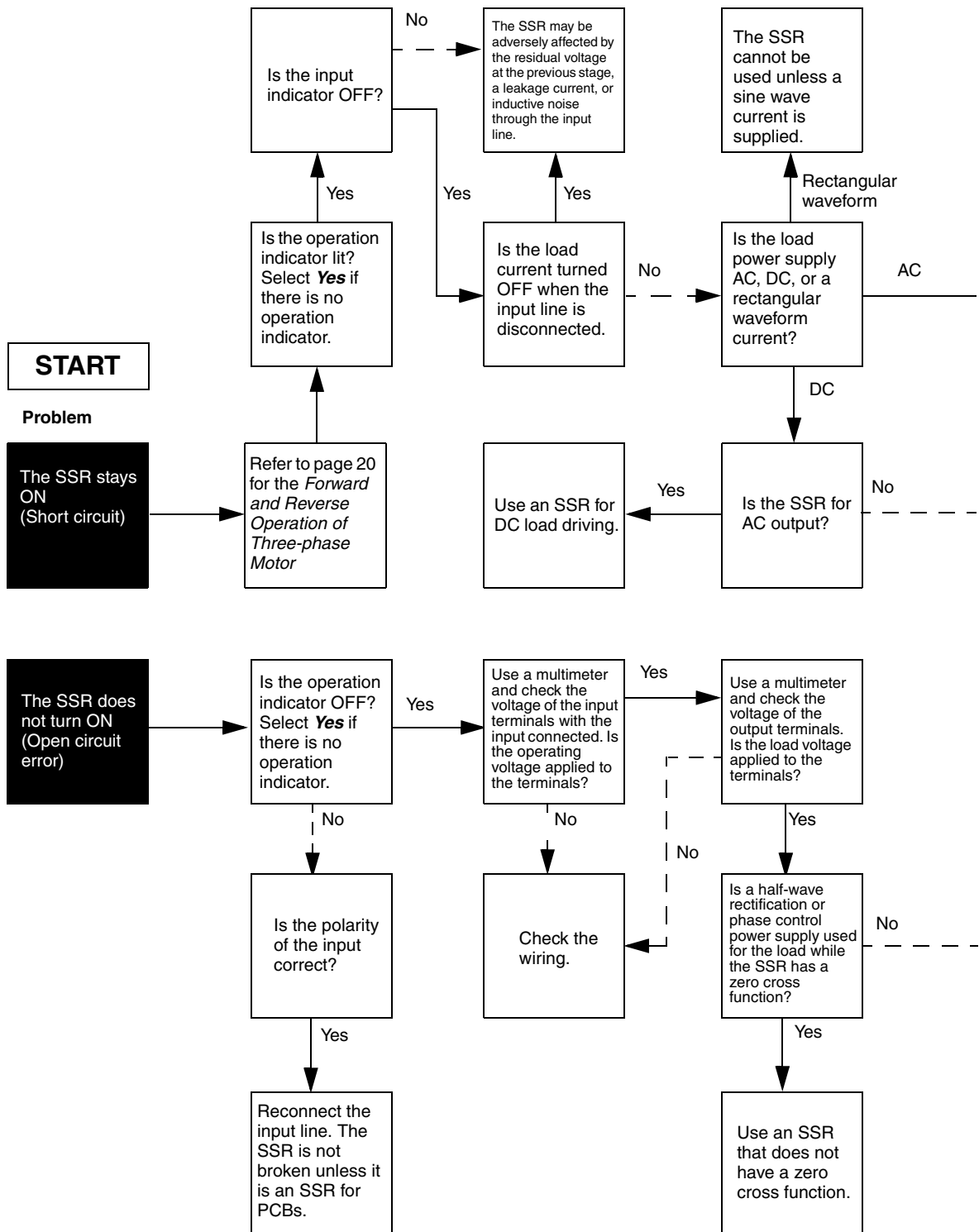

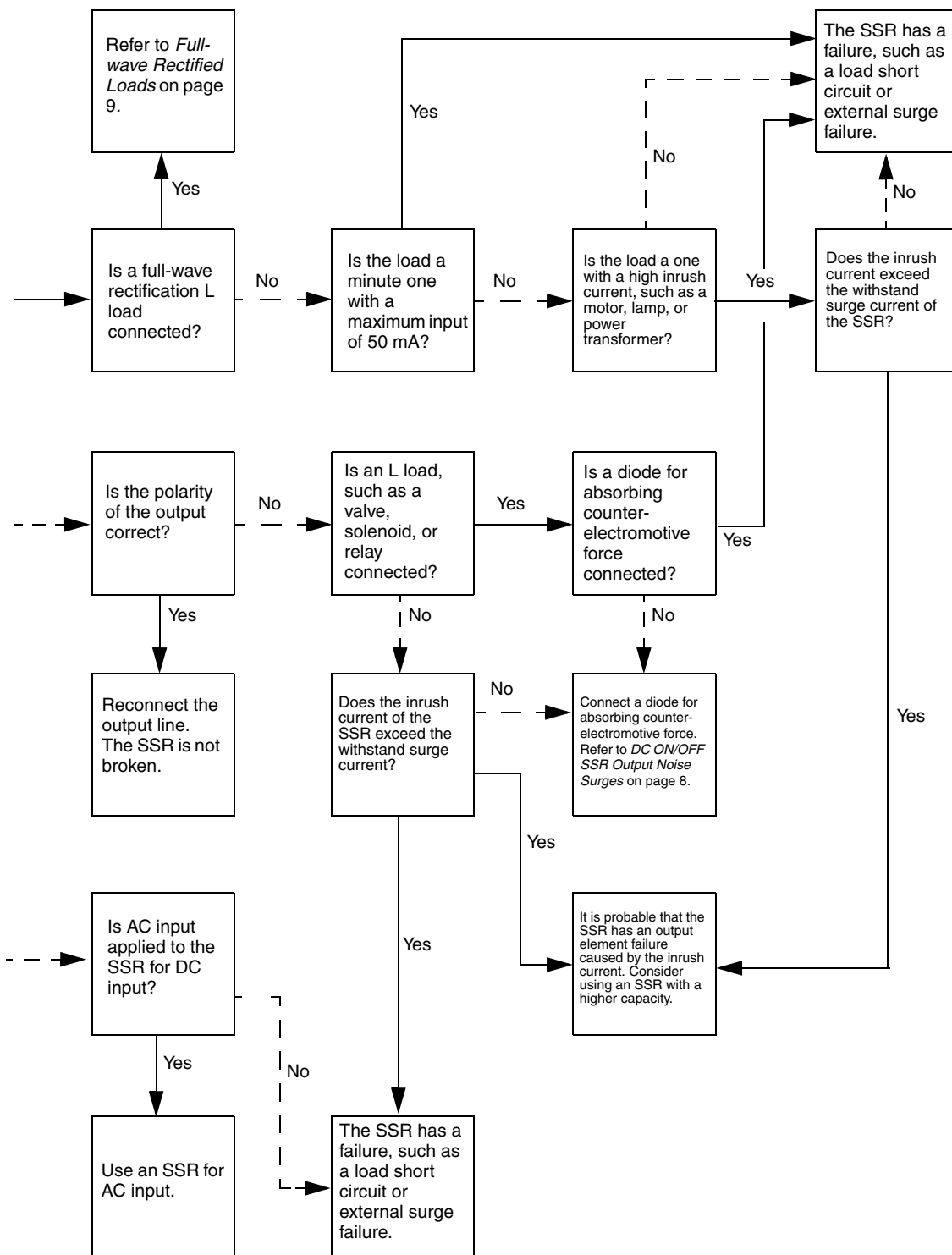

Q&A for SSRs

Q1 We think an SSR is faulty. Can a voltage tester be used to check an SSR to see if current is flowing?

A1 No, that is not possible. The voltage and current in the tester's internal circuits are too low to check the operation of the semiconductor element in the SSR (a triac or thyristor). The SSR can be tested as described below if a load is connected.

● Testing Method

Connect a load and power supply, and check the voltage of the load terminals with the input ON and OFF. The output voltage will be close to the load power supply voltage with the SSR turned OFF. The voltage will drop to approximately 1 V with the SSR turned ON. This is more clearly checked if the dummy load is a lamp with an output of about 100 W.

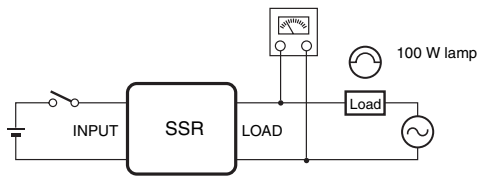

Q2 What kind of applications can power MOS FET relays be used for?

A2

- Applications where it is not known whether the load connected to the relay is AC or DC.
Example: Alarm output of robot controller.
- Applications with high-frequency switching of loads, such as for solenoid valves with internally, fully rectified waves, where the relay (e.g., G2R) has to be replaced frequently.
Power MOS FET relays have a longer lifetime than other relays and so the replacement frequency is less.
The terminals of the G3RZ are compatible with those of the G2R-1A-S and so these models can be exchanged.

Note: Confirm the input voltage, polarity, and output capacity before application.

- Applications with high-voltage DC loads.
In order to switch a 100-VDC, 1-A load with a relay, an MM2XP or equivalent is required. With the G3RZ power MOS FET relay, however, switching at this size is possible.
- Applications where SSRs are used with a bleeder resistance.
The leakage current for power MOS FET relays is very small (10 μ A max.) and so a bleeder resistance is not required.

Q3 What is the difference in switching with a thyristor and a triac?

A3 There is no difference between them as long as resistive loads are switched. For inductive loads, however, thyristors are superior to triacs due to the inverse parallel connection of the thyristors. For the switching element, an SSR uses either a triac or a pair of thyristors connected in an inverse parallel connection.

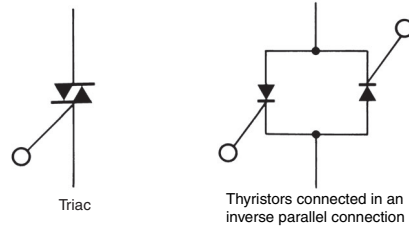

There is a difference between thyristors and triacs in response time to rapid voltage rises or drops. This difference is expressed by dv/dt (V/ μ s). This value of thyristors is larger than that of triacs. Triacs can switch inductive motor loads that are as high as 3.7 kW. Furthermore, a single triac can be the functional equivalent of a pair of thyristors connected in an inverse parallel connection and can thus be used to contribute to downsizing SSRs.

Note: dv/dt = Voltage rise rate.

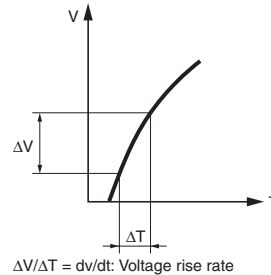

	Resistive load		Inductive load	
	40 A max.	Over 40 A	3.7 kW max.	Over 3.7 kW
Triac	OK	OK	OK	Not as good
Two thyristors	OK	OK	OK	OK

Q4 Is it possible to connect SSRs in series?

A4 Yes, it is. SSRs are connected in series mainly to prevent short circuit failures. Each SSR connected in series shares the burden of the surge voltage. The overvoltage is divided among the SSRs, reducing the load on each. A high operating voltage, however, cannot be applied to the SSRs connected in series. The reason is that the SSRs cannot share the burden of the load voltage due to the difference between the SSRs in operating time and reset time when the load is switched.

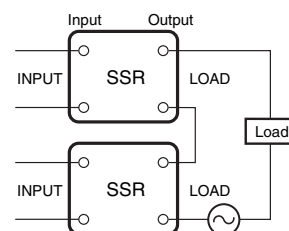

Q5 What needs to be done for surge absorption elements for SSRs for DC loads?

A5 Output Noise Surge Countermeasures for SSRs for DC Load Switching
 When an L load, such as a solenoid or electromagnetic valve, is connected, connect a diode that prevents counter-electromotive force. If the counter-electromotive force exceeds the withstand voltage of the SSR output element, it could result in damage to the SSR output element. To prevent this, insert the element parallel to the load, as shown in the following diagram and table.

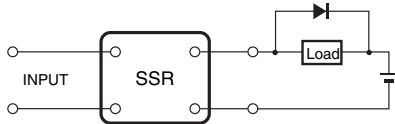

As an absorption element, the diode is the most effective at suppressing the counter-electromotive force. The release time for the solenoid or electromagnetic valve will, however, increase. Be sure to check the circuit before use. To shorten the time, connect a Zener diode and a regular diode in series. The release time will be shortened at the same rate that the Zener voltage (V_z) of the Zener diode is increased.

Table 1. Absorption Element Example

Absorption element				
Effectiveness	Most effective	Most effective	Somewhat effective	Ineffective

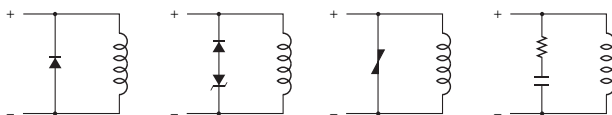

Reference

1. Selecting a Diode
 Withstand voltage = $V_{RM} \geq \text{Power supply voltage} \times 2$
 Forward current = $I_F \geq \text{load current}$
2. Selecting a Zener Diode
 Zener voltage =
 $V_z < (\text{Voltage between SSR's collector and emitter})^* - (\text{Power supply voltage} + 2 \text{ V})$
 Zener surge power =
 $P_{RSM} > V_z \times \text{Load current} \times \text{Safety factor (2 to 3)}$

Note: When the Zener voltage is increased (V_z), the Zener diode capacity (P_{RSM}) is also increased.

Q6 What is the zero cross function?

A6 The zero cross function turns ON the SSR when the AC load voltage is close to 0 V, thus suppressing the noise generation of the load current when the load current rises quickly. The generated noise will be partly imposed on the power line and the rest will be released in the air. The zero cross function effectively suppresses both noise paths. A high inrush current will flow when the lamp is turned ON, for example. When the zero cross function is used, the load current always starts from a point close to 0 V. This will suppress the inrush current more than SSRs without the zero cross function.

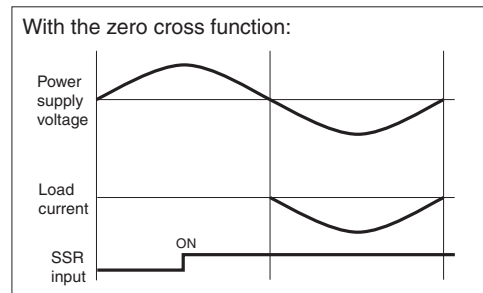
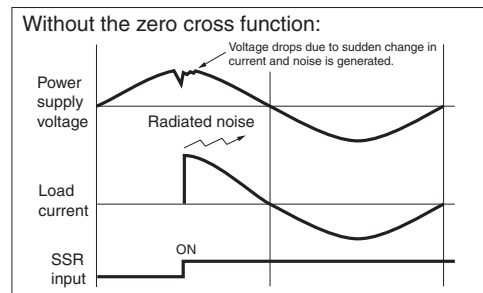

Q7 Is it possible to connect two 200-VAC SSRs in series to a 400-VAC load?

A7 No, it is not. The two SSRs are slightly different to each other in operating time. Therefore, 400 VAC will be imposed on the SSR with a longer operating time.

Q8**Is it possible to connect SSRs in parallel?****A8**

Yes, it is. SSRs are connected in parallel mainly to prevent open circuit failures. Usually, only one of the SSR is turned ON due to the difference in output ON voltage drop between the SSRs. Therefore, it is not possible to increase the load current by connecting the SSRs in parallel. If an ON-state SSR in operation is open, the other SSR will turn ON when the voltage is applied, thus maintaining the switching operation of the load. Do not connect two or more SSRs in parallel to drive a load exceeding the capacity each SSRs; the SSRs may fail to operate.

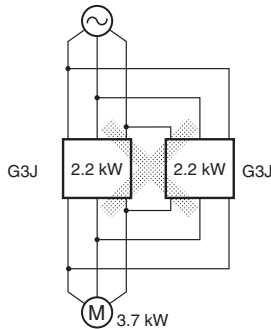

Example:
It is not possible to control a 3.7-kW heater with two SSRs for 2.2kW connected in parallel.

Q9**What is silicon grease?****A9**

Special silicon grease is used to aid heat dissipation. The heat conduction of this special compound is five to ten times higher than standard silicon grease. This special silicon grease is used to fill the space between a heat-radiating part, such as an SSR, and the heat sink to improve the heat conduction of the SSR.

Unless special silicon grease is applied, the generated heat of the SSR will not be radiated properly. As a result, the SSR may break or deteriorate due to overheating.

Available Silicon Grease Products for Heat Dissipation

Toshiba Silicone: YG6260
Shin-Etsu Silicones: G746

Q10**What precautions are necessary for forward/reverse operation of the singlephase motor?****A10**

Refer the following table for the protection of capacitor motors driven by SSRs.

Single-phase 100 V	Load current of recommended SSR	Protection of motor in forward/reverse operation
		R
25 W	AC 2 to 3 A	R = 6 Ω, 10 W
40 W		
60 W	AC 5 A	R = 4 Ω, 20 W
90 W		R = 3 Ω, 40 to 50 W

Single-phase 200 V	Load current of recommended SSR	Protection of motor in forward/reverse operation
		R
25 W	AC 2 to 3 A	R = 12 Ω, 10 W
40 W		
60 W	AC 5 A	R = 12 Ω, 20 W
90 W		R = 8 Ω, 40 W

Precautions for Forward/Reverse Operation

- In the following circuit, if SSR1 and SSR2 are turned ON simultaneously, the discharge current, i , of the capacitor may damage the SSRs. Therefore, a minimum 30-ms time lag is required to switch between SSR1 and SSR2. If the malfunction of the SSRs is possible due to external noise or the counter-electromotive force of the motor, connect L or r in series with either SSR1 or SSR2 whichever is less frequently use. A CR absorber (consisting of 0.1-μF capacitor withstanding 630 V and 22-Ω resistor withstanding 2 W) can be connected in parallel to each SSR so that the malfunctioning of the SSRs will be suppressed.

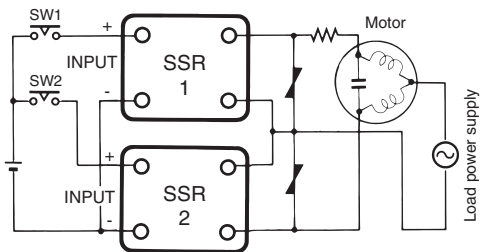

- When the motor is in forward/reverse operation, a voltage that is twice as high as the power supply voltage may be imposed on an SSR that is OFF due to the LC resonance of the motor. When selecting an SSR, be careful that this voltage does not exceed the rated load voltage of the SSR. (It is necessary to determine whether use is possible by measuring the actual voltage applied to the SSR on the OFF side.)

Q11 Does an SSR have a mounting direction?

A11 An SSR consists of semiconductor elements. Therefore, unlike mechanical relays that incorporate movable parts, gravity changes have no influence on the characteristics of the SSR. Changes in the heat radiation of an SSR may, however, limit the carry current of the SSR. An SSR should be mounted vertically. If the SSR has to be mounted horizontally, check with the SSR's datasheet. If there is no data available for the SSR, use with a load current at least 30% lower than the rated load current.

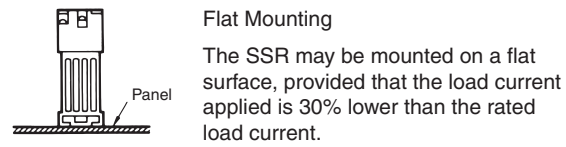
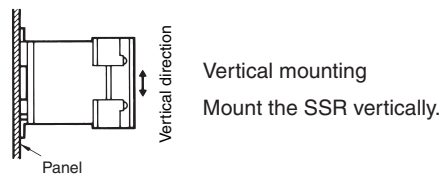
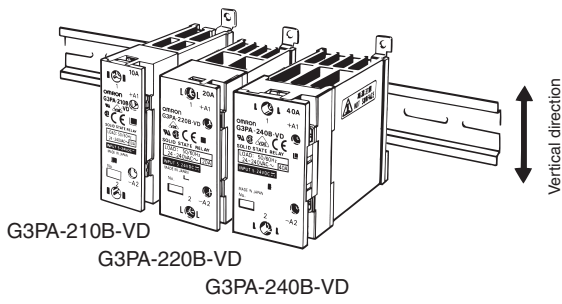

Q12 What precautions are required for high-density mounting or gang mounting?

A12 In the case of high-density or gang mounting of SSRs, check the relevant data in the SSR datasheet. If there is no data, check that the load current applied is 70% of the rated load current. A 100% load current can be applied if groups of three SSRs are mounted in a single row with a space as wide as a single SSR between adjacent groups. If the SSRs are mounted in two or more rows, it is necessary to confirm the temperature rise of the SSR separately. With side-by-side high-density or gang mounting of SSRs with heat sinks, reduce the load current to 80% of the rated load current. Refer to the SSR's datasheet for details.

G3PA

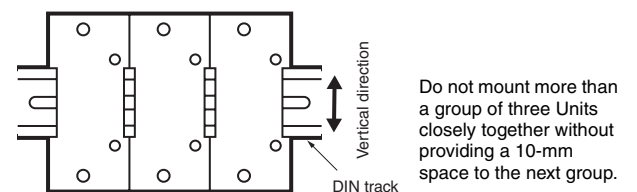

G3PE

Characteristic Data High-density or Gang Mounting (3 or 8 Units)

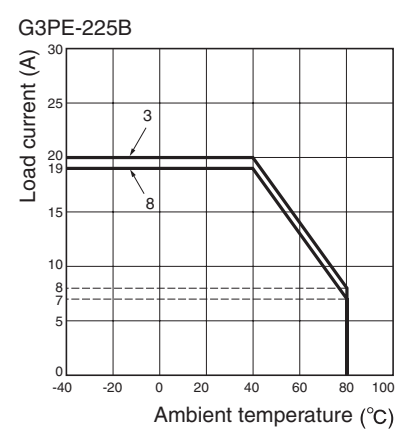
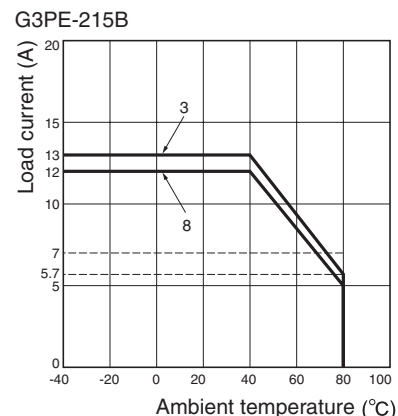

Example of high-density or gang mounting

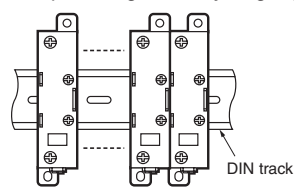

Q13 What is the non-repetitive inrush current?

A13 The datasheet of an SSR gives the non-repetitive inrush current of the SSR. The concept of the non-repetitive inrush current of an SSR is the same as an absolute maximum rating of an element. Once the inrush current exceeds the level of the non-repetitive inrush current, the SSR will be destroyed. Therefore, check that the maximum inrush current of the SSR in usual ON/OFF operation is 1/2 of the non-repetitive inrush current. Unlike mechanical relays that may result in contact abrasion, the SSR will provide good performance as long as the actual inrush current is a maximum of 1/2 of the non-repetitive inrush current. If the SSR is in continuous ON/OFF operation and a current exceeding the rated value flows frequently, however, the SSR may overheat and a malfunction may result. Check that the SSR is operated with no overheating. Roughly speaking, inrush currents that are less than the non-repetitive inrush current and greater than the repetitive inrush current can be withstood once or twice a day (e.g., this level of inrush current can be withstood in cases where power is supplied to devices once a day).

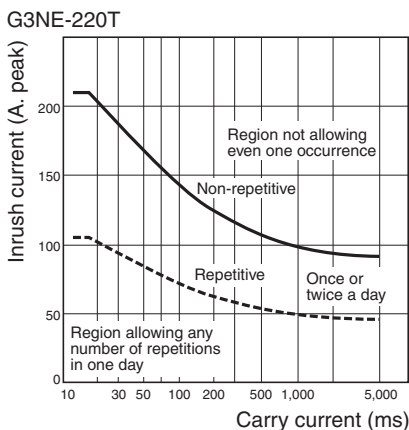

Q14 What kind of failure do SSRs have most frequently?

A14 OMRON's data indicates that most failures are caused by overvoltage or overcurrent as a result of the short-circuiting of SSRs. This data is based on SSR output conditions, which include those resulting from the open or short circuit failures on the input side.

	Failure	Load condition
Input	Short	Does not turn ON.
	Open	Does not turn ON.
Output	Output triac short circuit (80% of failures)	Does not turn OFF.
	Output triac open circuit (20% of failures)	Does not turn ON.

Q15 Why can MOS FET relays be used for both AC and DC loads?

A15 With power MOS FET relays, because 2 MOS FET relays are connected in series in the way shown on the right, the load power supply can be connected in either direction. Also, because power MOS FET elements have a high dielectric strength, they can be used for AC loads, where the polarity changes every cycle.

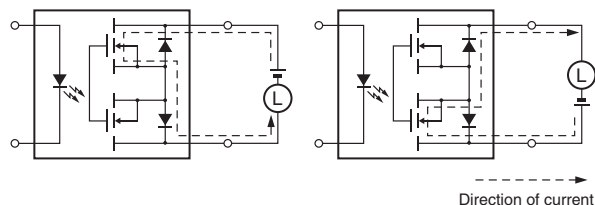

Q16 What are the differences between SSRs and power MOS FET relays?

A16 Number 1: There are SSRs for DC loads and SSRs for AC loads.

SSR for DC Loads (e.g., G3HD)

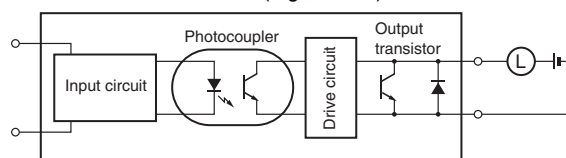

SSR for AC Loads (e.g., G3H)

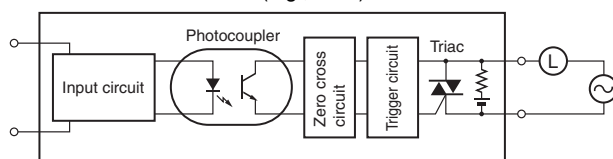

Power MOS FET relays can be used for both DC loads and AC loads.

Number 2: The leakage current for power MOS FET relays is small compared to that for SSRs.

SSRs
The lamp (see below) is faintly light by the leakage current. A bleeder resistance is added to prevent this. With SSRs, a snubber circuit is required to protect the output element.

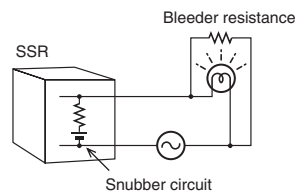

Power MOS FET Relays

The leakage current is very small (10 μA max.) and so the lamp does not light. This is because a snubber circuit is not required to protect the MOS FET output element. A varistor is used to protect the MOS FET.

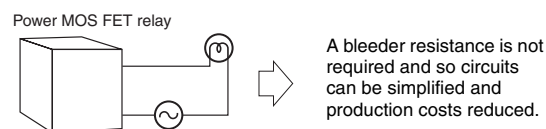

Installing, Maintaining, and Inspecting SSRs

Fail-safe Concept

1. Error Mode

The SSR is an optimum relay for high-frequency switching and high-speed switching, but misuse or mishandling of the SSR may damage the elements and cause other problems. The SSR consists of semiconductor elements, and will break down if these elements are damaged by surge voltage or overcurrent. Most faults associated with the elements are short-circuit malfunctions, whereby the load cannot be turned OFF.

Therefore, to provide a fail-safe feature for a control circuit using an SSR, design a circuit in which a contactor or circuit breaker on the load power supply side will turn OFF the load when the SSR causes an error. Do not design a circuit that only turns OFF the load power supply with the SSR. For example, if the SSR causes a half-wave error in a circuit in which an AC motor is connected as a load, DC energizing may cause overcurrent to flow through the motor, thus burning the motor. To prevent this from occurring, design a circuit in which a circuit breaker stops overcurrent to the motor.

Location	Cause	Result
Input area	Overvoltage	Input element damage
Output area	Overvoltage	Output element damage
	Overcurrent	
Whole Unit	Ambient temperature exceeding maximum	Output element damage
	Poor heat radiation	

2. Overcurrent Protection

A short-circuit current or an overcurrent flowing through the load of the SSR will damage the output element of the SSR. Connect a quick-break fuse in series with the load as an overcurrent protection measure.

Design a circuit so that the protection coordination conditions for the quick-break fuse satisfy the relationship between the SSR surge resistance (I_s), quick-break fuse current-limiting feature (I_f), and the load inrush current (I_L), shown in the following chart.

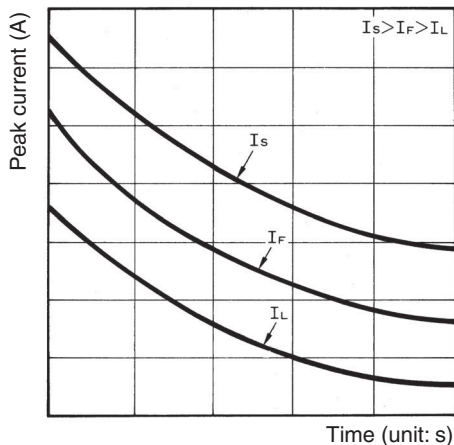

Note: Provide an appropriate non-fuse breaker to each machine for the overcurrent protection of the machine.

3. Operation Indicator

The operation indicator turns ON when current flows through the input circuit. It does not indicate that the output element is ON.

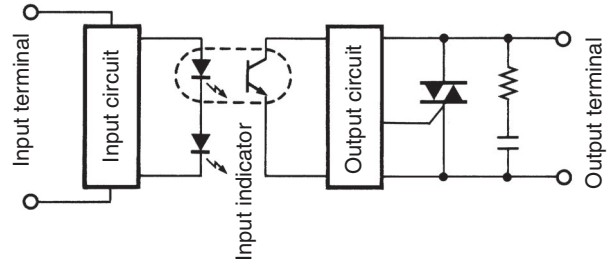

Application Circuit Examples

1. Connection to Sensor

The SSR connects directly to the Proximity Sensor and Photoelectric Sensor.

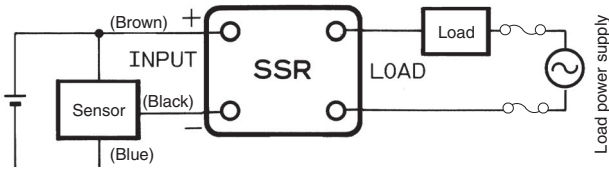

2. Switching Control of Incandescent Lamp

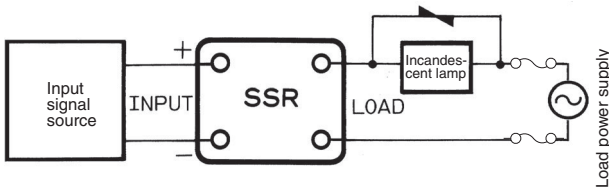

3. Temperature Control of Electric Furnace

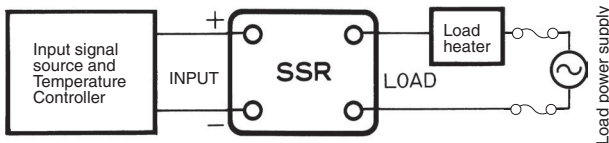

4. Forward and Reverse Operation of Single-phase Motor

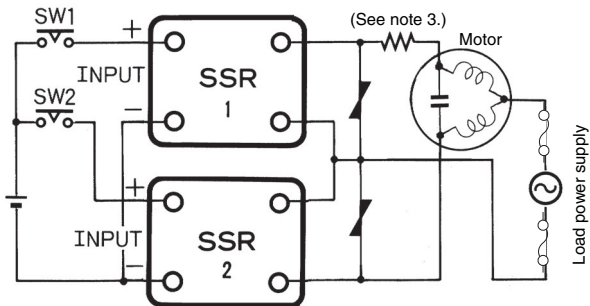

Note: 1. The voltage between the load terminals of either SSR 1 or SSR 2 turned OFF is approximately twice as high as the supply voltage due to LC coupling. Be sure to apply an SSR model with a rated output voltage of at least twice the supply voltage.

For example, if forward/reverse operation is to be performed on a single-phase inductive motor with a supply voltage of 100 VAC, the SSR must have an output voltage of 200 VAC or higher.

2. Make sure that there is a time lag of 30 ms or more to switch over SW1 and SW2.
3. Resistor to limit advanced phase capacitor discharge current. To select a suitable resistor, consult with the manufacturer of the motor.

5. ON/OFF Control of Three-phase Inductive Motor

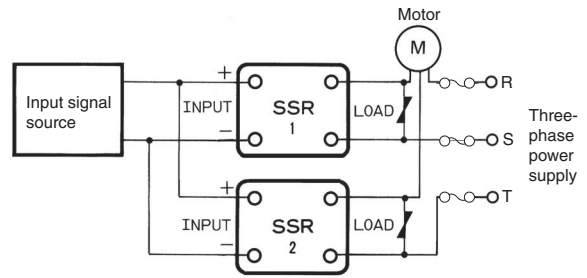

6. Forward and Reverse Operation of Three-phase Motor

Make sure that signals input into the SSR Units are proper if the SSR Units are applied to the forward and reverse operation of a three-phase motor. If SW1 and SW2 as shown in the following circuit diagram are switched over simultaneously, a phase short-circuit will result on the load side, which may damage the output elements of the SSR Units. This is because the SSR has a triac as an output element that is turned ON until the load current becomes zero regardless of the absence of input signals into the SSR.

Therefore, make sure that there is a time lag of 30 ms or more to switch over SW1 and SW2.

The SSR may be damaged due to phase short-circuiting if the SSR malfunctions with noise in the input circuit of the SSR. To protect the SSR from phase short-circuiting damage, the protective resistance R may be inserted into the circuit.

The value of the protective resistance R must be determined according to the withstand surge current of the SSR. For example, the G3NA-220B withstands an inrush current of 220 A. The value of the protective resistance R is obtained from the following.

$$R > 220 \text{ V} \times \sqrt{2} / 200 \text{ A} = 1.4 \Omega$$

Considering the circuit current and ON time, insert the protective resistance into the side that reduces the current consumption.

Obtain the consumption power of the resistance from the following.

$$P = I^2 R \times \text{Safety factor}$$

$$(I = \text{Load current}, R = \text{Protective resistance}, \text{Safety factor} = 3 \text{ to } 5)$$

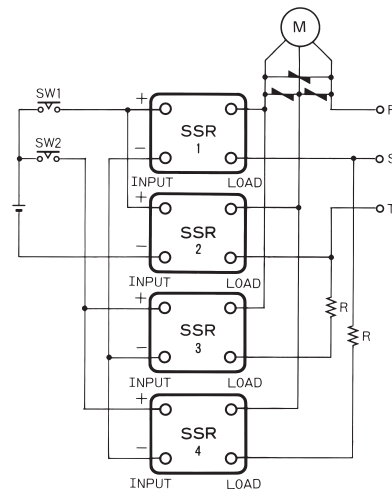

7. Inrush Currents to Transformer

Loads

The inrush current from a transformer load will reach its peak when the secondary side of the transformer is open, when no mutual reactance will work. It will take half a cycle of the power supply frequency for the inrush current to reach its peak, the measurement of which without an oscilloscope will be difficult.

The inrush current can be, however, estimated by measuring the DC resistance of primary side of the transformer.

Due to the self-reactance of the transformer in actual operation, the actual inrush current will be less than the calculated value.

$$I_{\text{peak}} = V_{\text{peak}}/R = (\sqrt{2} \times V) / R$$

If the transformer has a DC resistance of 3 Ω and the load power supply voltage is 220 V, the following inrush current will flow.

$$I_{\text{peak}} = (1.414 \times 220)/3 = 103.7 \text{ A}$$

The withstand surge current of OMRON's SSRs is specified on condition that the SSRs are in non-repetitive operation (one or two operations). If your application requires repetitive SSR switching, use an SSR with an inrush current resistance twice as high as the rated value (I peak).

In the case above, use the G3□□-220□ with an withstand surge current of 207.4 A or more.

The DC resistance of primary side of the transformer can be calculated back from the withstand surge current by using the following formula.

$$R = V_{\text{peak}}/I_{\text{peak}} = (\sqrt{2} \times V) / I_{\text{peak}}$$

For applicable SSRs based on the DC resistance of the primary side of the transformer, refer to the tables below.

These tables list SSRs with corresponding inrush current conditions. When using SSRs to actual applications, however, check that the steady-state currents of the transformers satisfy the rated current requirement of each SSR.

SSR Rated Current

G3□□-240□

The underlined two digits refer to the rated current (i.e., 40 A in the case of the above model).

Three digits may be used for the G3NH only.

G3NH: G3NH-□075B = 75 A
G3NH-□150B = 150 A

Condition 1: The ambient temperature of the SSR (the temperature inside the panel) is within the rated value specified.

Condition 2: The right heat sink is provided to the SSR.

Load Power Supply Voltage: 100 V

Transformer DC resistance (Ω)	Inrush current (A)	SSR inrush current resistance (A)	Applicable SSR			
			G3P□	G3NA	G3NE	G3NH
4.8 min.	30	60	---	-205□	-205□	---
1.9 to 4.7	75	150	-210□ -215□	-210□	-210□	---
1.3 to 1.8	110	220	-220□ -225□	-220□	-220□	---
0.65 to 1.2	220	440	-235□ -240□ -245□ -260□	-240□	---	---
0.36 to 0.64	400	800	---	---	---	-2075□
0.16 to 0.35	900	1,800	---	---	---	-2150□

Load Power Supply Voltage: 110 V

Transformer DC resistance (Ω)	Inrush current (A)	SSR inrush current resistance (A)	Applicable SSR			
			G3P□	G3NA	G3NE	G3NH
5.2 min.	30	60	---	-205□	-205□	---
2.1 to 5.1	75	150	-210□ -215□	-210□	-210□	---
1.5 to 2.0	110	220	-220□ -225□	-220□	-220□	---
0.71 to 1.4	220	440	-235□ -240□ -245□ -260□	-240□	---	---
0.39 to 0.70	400	800	---	---	---	-2075□
0.18 to 0.38	900	1,800	---	---	---	-2150□

Load Power Supply Voltage: 120 V

Transformer DC resistance (Ω)	Inrush current (A)	SSR inrush current resistance (A)	Applicable SSR			
			G3P□	G3NA	G3NE	G3NH
5.7 min.	30	60	---	-205□	-205□	---
2.3 to 5.6	75	150	-210□ -215□	-210□	-210□	---
1.6 to 2.2	110	220	-220□ -225□	-220□	-220□	---
0.78 to 1.5	220	440	-235□ -240□ -245□ -260□	-240□	---	---
0.43 to 0.77	400	800	---	---	---	-2075□
0.19 to 0.42	900	1,800	---	---	---	-2150□

Load Power Supply Voltage: 200 V

Transformer DC resistance (Ω)	Inrush current (A)	SSR inrush current resistance (A)	Applicable SSR			
			G3P□	G3NA	G3NE	G3NH
9.5 min.	30	60	---	-205□	-205□	---
3.8 to 9.4	75	150	-210□ -215□	-210□	-210□	---
2.6 to 3.7	110	220	-220□ -225□	-220□	-220□	---
1.3 to 2.5	220	440	-235□ -240□ -245□ -260□	-240□	---	---
0.71 to 1.2	400	800	---	---	---	-2075□
0.32 to 0.70	900	1,800	---	---	---	-2150□

Load Power Supply Voltage: 220 V

Transformer DC resistance (Ω)	Inrush current (A)	SSR inrush current resistance (A)	Applicable SSR			
			G3P□	G3NA	G3NE	G3NH
10.4 min.	30	60	---	-205□	-205□	---
4.2 to 10.3	75	150	-210□ -215□	-210□	-210□	---
2.9 to 4.1	110	220	-220□ -225□	-220□	-220□	---
1.5 to 2.8	220	440	-235□ -240□ -245□ -260□	-240□	---	---
0.78 to 1.4	400	800	---	---	---	-2075□
0.35 to 0.77	900	1,800	---	---	---	-2150□

Load Power Supply Voltage: 240 V

Transformer DC resistance (Ω)	Inrush current (A)	SSR inrush current resistance (A)	Applicable SSR			
			G3P□	G3NA	G3NE	G3NH
11.4 min.	30	60	---	-205□	-205□	---
4.6 to 11.3	75	150	-210□ -215□	-210□	-210□	---
3.1 to 4.5	110	220	-220□ -225□	-220□	-220□	---
1.6 to 3.0	220	440	-235□ -240□ -245□ -260□	-240□	---	---
0.85 to 1.5	400	800	---	---	---	-2075□
0.38 to 0.84	900	1,800	---	---	---	-2150□

Load Power Supply Voltage: 400 V

Transformer DC resistance (Ω)	Inrush current (A)	SSR inrush current resistance (A)	Applicable SSR			
			G3P□	G3NA	G3NE	G3NH
7.6 min.	75	150	---	-410□	---	---
5.2 to 7.5	110	220	-420□ -430□	-420□	---	---
2.6 to 5.1	220	440	-435□ -445□	---	---	---
1.5 to 2.5	400	800	---	---	---	-4075□
0.63 to 1.4	900	1,800	---	---	---	-4150□

Load Power Supply Voltage: 440 V

Transformer DC resistance (Ω)	Inrush current (A)	SSR inrush current resistance (A)	Applicable SSR			
			G3P□	G3NA	G3NE	G3NH
8.3 min.	75	150	---	-410□	---	---
5.7 to 8.2	110	220	-420□ -430□	-420□	---	---
2.9 to 5.6	220	440	-435□ -450□	---	---	---
1.6 to 2.8	400	800	---	---	---	-4075□
0.70 to 1.5	900	1,800	---	---	---	-4150□

Load Power Supply Voltage: 480 V

Transformer DC resistance (Ω)	Inrush current (A)	SSR inrush current resistance (A)	Applicable SSR			
			G3P□	G3NA	G3NE	G3NH
9.1 min.	75	150	---	-410□	---	---
6.2 to 9.0	110	220	-420□ -430□	-420□	---	---
3.1 to 6.1	220	440	-450□	---	---	---

8. Transformer Tap Selection

SSRs can be used to switch between transformer taps. In this case, however, be aware of voltage induced on the OFF-side SSR. The induced voltage increases in proportion to the number of turns of the winding that is almost equivalent to the tap voltage.

See the following example. The power supply voltage is at 200 V, N1 is 100, N2 is 100, and SSR2 is ON. Then the difference in voltage between output terminals of SSR1 is at 400 V (i.e., twice as high as the power supply voltage).

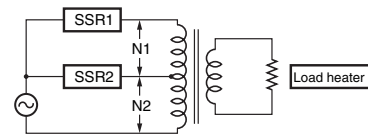

■ Designing SSR Circuits

Heat Radiation Designing

1. SSR Heat Radiation

Triacs, thyristors, and power transistors are semiconductors that can be used for an SSR output circuit. These semiconductors have a residual voltage internally when the SSR is turned ON. This is called output-ON voltage drop. If the SSR has a load current, the Joule heating of the SSR will result consequently. The heating value P (W) is obtained from the following formula.

Heating value P (W) = Output-ON voltage drop (V) × Carry current (A)

For example, if a load current of 8 A flows from the G3NA-210B, the following heating value will be obtained.

$$P = 1.6 \text{ V} \times 8 \text{ A} = 12.8 \text{ W}$$

If the SSR employs power MOS FET for SSR output, the heating value is calculated from the ON-state resistance of the power MOS FET instead.

In that case, the heating value P (W) will be obtained from the following formula.

$$P (\text{W}) = \text{Load current}^2 (\text{A}) \times \text{ON-state resistance} (\Omega)$$

If the G3RZ with a load current of 0.5 A is used, the following heating value will be obtained.

$$P (\text{W}) = 0.5^2 \text{ A} \times 2.4 \Omega = 0.6 \text{ W}$$

The ON-state resistance of a power MOS FET rises with an increase in the junction temperature of a power MOS FET. Therefore, the ON-state resistance varies while the SSR is in operation. If the load current is 80% of the load current or higher, as a simple method, the ON-state resistance will be multiplied by 1.5.

$$P (\text{W}) = 1^2 \text{ A} \times 2.4 \Omega \times 1.5 = 3.6 \text{ W}$$

The SSR in usual operation switches a current of approximately 5 A with no heat sink used. If the SSR must switch a higher current, a heat sink will be required. The higher the load current is, the larger the heat sink size will be. If the switching current is 10 A or more, the size of the SSR with a heat sink will exceed a single mechanical relay. This is a disadvantage of SSRs for circuit downsizing purposes.

2. Heat Sink Selection

SSR models with no heat sinks incorporated (i.e., the G3NA, G3NE, and three-phase G3PB) need external heat sinks. When using any of these SSRs, select an ideal combination of the SSR and heat sink according to the load current.

The following combinations are ideal, for example.

G3NA-220B: Y92B-N100
 G3NE-210T(L): Y92B-N50
 G3PB-235B-3H-VD: Y92B-P200

A standard heat sink equivalent to an OMRON-made one can be used, on condition that the thermal resistance of the heat sink is lower than that of the OMRON-made one.

For example, the Y92B-N100 has a thermal resistance of 1.63°C/W. If the thermal resistance of the standard heat sink is lower than this value (i.e., 1.5°C/W, for example), the standard heat sink can be used for the G3NA-220B.

Thermal resistance indicates a temperature rise per unit (W). The smaller the value is, the higher the efficiency of heat radiation will be.

3. Calculating Heat Sink Area

An SSR with an external heat sink can be directly mounted to control panels under the following conditions.

- If the heat sink is made of steel used for standard panels, do not apply a current as high as or higher than 10 A, because the heat conductivity of steel is less than that of aluminum. Heat conductivity (in units of W·m·°C) varies with the material as described below.

Steel: 20 to 50

Aluminum: 150 to 220

The use of an aluminum-made heat sink is recommended if the SSR is directly mounted to control panels. Refer to the data sheet of the SSR for the required heat sink area.

- Apply heat-radiation silicon grease (e.g., the YG6260 from Toshiba or the G746 from Shin-Etsu) or a heat conductive sheet between the SSR and heat sink. There will be a space between the SSR and heat sink attached to the SSR. Therefore, the generated heat of the SSR cannot be radiated properly without the grease. As a result, the SSR may be overheated and damaged or deteriorated.

The heat dissipation capacity of a heat conduction sheet is generally inferior to that of silicon grease. If a heat conduction sheet is used, reduce the load current by approximately 10% from the *Load Current vs. Ambient Temperature Characteristics* graph.

4. Control Panel Heat Radiation

Designing

Control equipment using semiconductors will generate heat, regardless of whether SSRs are used or not. The failure rate of semiconductors greatly increases when the ambient temperature rises. It is said that the failure rate of semiconductors will be doubled when the temperature rises 10°C (Arrhenius model).

Therefore, it is absolutely necessary to suppress the interior temperature rise of the control panel in order to ensure the long, reliable operation of the control equipment.

Heat-radiating devices in a wide variety exists in the control panel. As a matter of course, it is necessary to consider the total temperature rise as well as local temperature rise of the control panel. The following description provides information on the total heat radiation designing of the control panel.

As shown below, the heat conductivity Q will be obtained from the following formula, provided that t_h and t_c are the temperature of the hot fluid and that of the cool fluid separated by the fixed wall.

$$Q = k (t_h - t_c) A$$

Where, k is an overall heat transfer coefficient (W/m²·°C). This formula is called a formula of overall heat transfer.

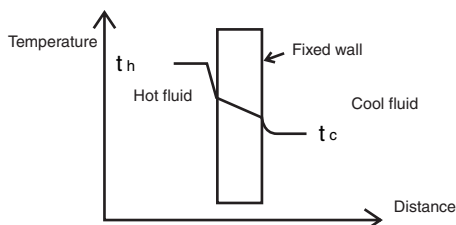

When this formula is applicable to the heat conductivity of the control panel under the following conditions, the heat conductivity Q will be obtained as shown below.

Average rate of overall heat transfer of control panel: k (W/m²·°C)

Internal temperature of control panel: T_h (°C)

Ambient temperature: T_c (°C)

Surface area of control panel: S (m²)

$$Q = k \times (T_h - T_c) \times S$$

The required cooling capacity is obtained from the following formula under the following conditions.

Desired internal temperature of control panel: T_h (°C)

Total internal heat radiation of control panel: P_1 (W)

Required cooling capacity: P_2 (W)

$$P_2 = P_1 - k \times (T_h - T_c) \times S$$

The overall heat transfer coefficient k of a standard fixed wall in a place with natural air ventilation will be 4 to 12 (W/m²·°C). In the case of a standard control panel with no cooling fan, it is an empirically known fact that a coefficient of 4 to 6 (W/m²·°C) is practically applicable. Based on this, the required cooling capacity of the control panel is obtained as shown below.

Example

- Desired internal temperature of control panel: 40°C

- Ambient temperature: 30°C

- Control panel size 2.5 × 2 × 0.5 m (W × H × D)
 Self-sustained control panel (with the bottom area excluded from the calculation of the surface area)

- SSR: 20 G3PA-240B Units in continuous operation at 30 A.

- Total heat radiation of all control devices except SSRs: 500 W

Total heat radiation of control panel: P_1

$$P_1 = \text{Output-ON voltage drop } 1.6 \text{ V} \times \text{Load current } 30 \text{ A} \times 20 \text{ SSRs} + \text{Total heat radiation of all control devices except SSRs} = 960 \text{ W} + 500 \text{ W} = 1460 \text{ W}$$

Heat radiation from control panel: Q_2

$$Q_2 = \text{Rate of overall heat transfer } 5 \times (40^\circ\text{C} - 30^\circ\text{C}) \times (2.5 \text{ m} \times 2 \text{ m} \times 2 + 0.5 \text{ m} \times 2 \text{ m} \times 2 + 2.5 \text{ m} \times 0.5 \text{ m}) = 662.5 \text{ W}$$

Therefore, the required cooling capacity P_2 will be obtained from the following formula.

$$P_2 = 1,460 - 663 = 797 \text{ W}$$

Therefore, heat radiation from the surface of the control panel is insufficient. More than a heat quantity of 797 W needs to be radiated outside the control panel.

Usually, a ventilation fan with a required capacity will be installed. If the fan is not sufficient, an air conditioner for the control panel will be installed. The air conditioner is ideal for the long-time operation of the control panel because it will effectively dehumidify the interior of the control panel and eliminate dust gathering in the control panel.

Axial-flow fan: OMRON's R87B, R87F, and R87T Series

Air conditioner for control panel: Apiste's ENC Series

5. Types of Cooling Device

Axial-flow Fans (for Ventilation)

These products are used for normal types of cooling and ventilation. OMRON's Axial-flow Fan lineup includes the R87F and R87T Series.



Heat Exchangers

Heat exchangers dissipate the heat inside control panels along heat pipes. Using a heat exchanger enables the inside and outside of the control panel to be mutually isolated, allowing use in locations subject to dust or oil mist.

Note: OMRON does not produce heat exchangers.



Air Conditioners for Control Panels

Not only do these products offer the highest cooling capacity, they also offer resistance to dust and humidity by mutually isolating the inside and outside of the control panel.

Note: OMRON does not produce air conditioners for control panels.



■ Mounting and Installation

Panel Mounting

If SSRs are mounted inside an enclosed panel, the radiated heat of the SSR will stay inside, thus not only dropping the carry-current capacity of the SSRs but also adversely affecting other electronic device mounted inside. Open some ventilation holes on the upper and lower sides of the control panel before use.

The following illustrations provide a recommended mounting example of G3PA Units. They provide only a rough guide and so be sure to confirm operating conditions using the procedure detailed in (4) Confirmation after Installation on page 26.

1. SSR Mounting Pitch

Panel Mounting

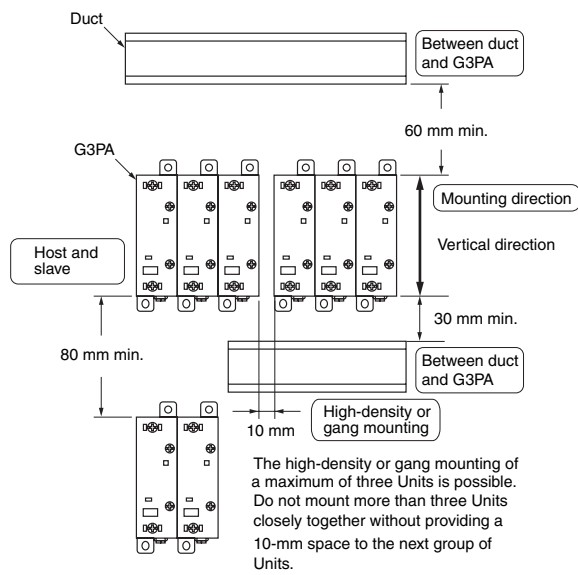

2. Relationship between SSRs and Ducts

Duct Depth

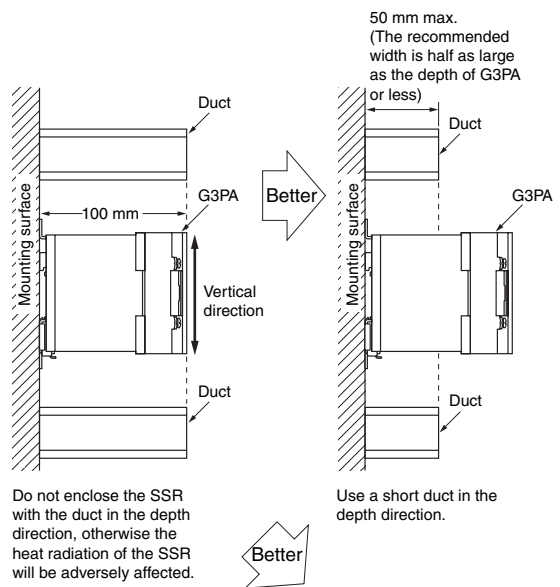

3. Ventilation

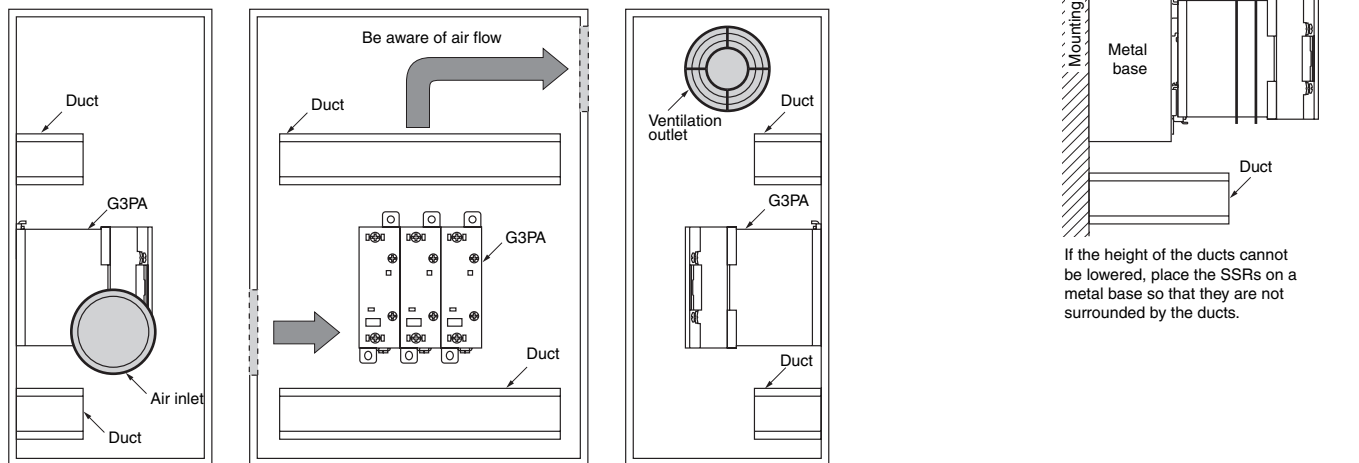

If the air inlet or air outlet has a filter, clean the filter regularly to prevent it from clogging and ensure an efficient flow of air.

Do not locate any objects around the air inlet or air outlet, or otherwise the objects may obstruct the proper ventilation of the control panel.

A heat exchanger, if used, should be located in front of the G3PA Units to ensure the efficiency of the heat exchanger.

4. Confirmation after Installation

The above conditions are typical examples confirmed by OMRON. The application environment may affect conditions and ultimately the ambient temperature must be measured under power application to confirm that the load current-ambient temperature ratings are satisfied for each model.

Ambient Temperature Measurement Conditions

1. Measure the ambient temperature under the power application conditions that will produce the highest temperature in the control panel and after the ambient temperature has become saturated.
2. Refer to *Figure 1* for the measurement position. If there is a duct or other equipment within the measurement distance of 100 mm, refer to *Figure 2*. If the side temperature cannot be measured, refer to *Figure 3*.

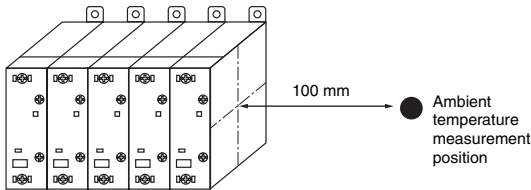

Figure 1: Basic Measurement Position for Ambient Temperature

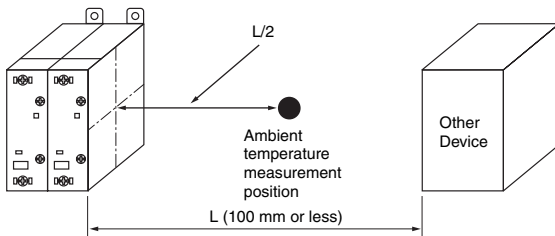

Figure 2: Measurement Position when a Duct or Other Device is Present

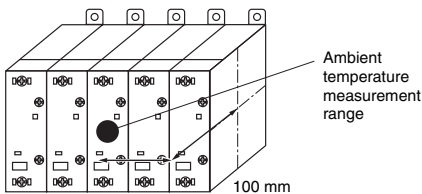

Figure 3: Measurement Position when Side Temperature Cannot be Measured

3. If more than one row of SSRs are mounted in the control panel, measure the ambient temperature of each row, and use the position with the highest temperature. Consult your OMRON dealer, however, if the measurement conditions are different from those given above.

Definition of Ambient Temperature

SSRs basically dissipate heat by natural convection. Therefore, the ambient temperature is the temperature of the air that dissipates the heat of the SSR.

ALL DIMENSIONS SHOWN ARE IN MILLIMETERS.

To convert millimeters into inches, multiply by 0.03937. To convert grams into ounces, multiply by 0.03527.

In the interest of product improvement, specifications are subject to change without notice.