

SENTECH

FS-B2KU7CL

FS-B4KU7CL

FS-B4KU35CL

FS-B8KU7CL

FS-B8KU35CL

FS-B16KU35CL

Monochrome Line Scanning
Camera Link Camera

Safety Precautions

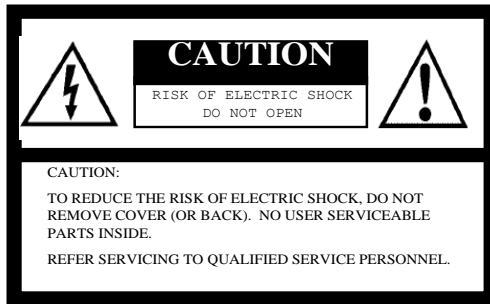

The lightning flash with arrowhead symbol, within an equilateral triangle, is intended to alert the user to the presence of uninsulated “dangerous voltage” within the product’s enclosure that may be of sufficient magnitude to constitute a risk of electric shock to persons.



The exclamation point within an equilateral triangle is intended to alert the user to the presence of important operating and maintenance (servicing) instructions in the literature accompanying the appliance.

For U.S.A.

Warning:

This equipment generates and uses radio frequency energy and if not installed and used properly, i.e., in strict accordance with the instruction manual, may cause harmful interference to radio communications. It has been tested and found to comply with the limits for a Class A computing device pursuant to Subpart J of Part 15 of FCC Rules, which are designed to provide reasonable protection against such interference when operated in a commercial environment.

For Canada

Warning:

This digital apparatus does not exceed the Class A limits for radio noise emissions from digital apparatus set out in the Radio Interference Regulations of the Canadian Department of Communications.

WARNING:

TO PREVENT FIRE OR SHOCK HAZARD, DO NOT EXPOSE THIS APPLIANCE TO RAIN OR MOISTURE.

Product Precautions

- Handle the camera with care. Do not abuse the camera. Avoid striking or shaking it. Improper handling or storage could damage the camera.
- Do not pull or damage the camera cable.
- During camera use, do not wrap the unit in any material. This will cause the internal temperature of the unit to increase.
- Do not expose the camera to moisture, or do not try to operate it in wet areas.
- Do not operate the camera beyond its temperature, humidity and power source ratings.
- While the camera is not being used, keep the lens or lens cap on the camera to prevent dust or contamination from getting in the CCD or filter area and scratching or damaging this area.
- Do not keep the camera under the following conditions:
 - In wet, moist, and high humidity areas
 - Under hot direct sunlight
 - In high temperature areas
 - Near an object that releases a strong magnetic or electric field
 - Areas with strong vibrations
- Use a soft cloth to clean the camera. Use pressured air spray to clean the surface of the glass. DO not scratch the surface of the glass.

Copyright & Disclaimer

Sensor Technologies America, Inc. (DBA Sentech America) believes the contents and specifications of its website, catalog, documentation and ads are correct; however, Sentech America provides no representation or warranty regarding such information or product(s) contained therein. It is requested that Sentech America be given appropriate acknowledgement in any subsequent use of such work by a third party.

While every effort has been made to ensure that the details contained in Sentech America's website and all documentation are correct and up-to-date, Sentech America assumes no liability, legal or otherwise for any errors in listings, specifications, part numbers, process, software or model applications. Sentech America reserves the right to change specifications, product descriptions, product quality, pricing and application at any time without prior written or oral notice. Any party using such information assumes all risk for any and all damaged caused to themselves, a third party and/or property by virtue of incorrect information and/or failure of these products. By installing and/or using a Sentech America software development kit or other similar product and/or information obtained from Sentech America's website, catalog, documentation or ads, you hereby accept and understand these stated terms and conditions.

Contents

I. Electronic Specifications / Mechanical Specifications / Environmental Specifications.....	5-6
II. Product Numbering	7
III. Connector Specifications	8-13
IV. Timing Chart	14-15
A. Exposure Time	14-16
V. Output Mode.....	17-29
VI. Communication Settings	30-33
VII. Command Description.....	34-40
VIII. Others.....	41-42
A. Outline on the camera memories-related CPU.....	41
B. Outline on the camera memories-related FFC.....	42
IX. Test Patterns.....	43-45
X. Quantum Efficiency	46
XI. Dimensions	47-49

I. Electronic Specifications / Mechanical Specifications / Environmental Specifications

Product		FS-B16KU35CL	FS-B8KU7CL	FS-B8KU35CL	FS-B4KU7CL	FS-B4KU35CL	FS-B2KU7CL
Image Sensor		16k CMOS image sensor DR-16k-3.5 (AWAIBA)	8k CMOS image sensor DR-8k-7 (AWAIBA)	8k CMOS image sensor DR-8k-3.5 (AWAIBA)	4k CMOS image sensor DR-4k-7 (AWAIBA)	4k CMOS image sensor DR-4k-3.5 (AWAIBA)	2k CMOS image sensor DR-2k-7 (AWAIBA)
Active Pixels		16,384 pixels	8,192 pixels		4,096 pixels		2,048 pixels
Pixel Size		3.5 (H) x 3.5 (V) um (3.5 um pitch)	7 (H) x 7 (V) um (7 um pitch)	3.5 (H) x 3.5 (V) um (3.5 um pitch)	7 (H) x 7 (V) um (7 um pitch)	3.5 (H) x 3.5 (V) um (3.5 um pitch)	7 (H) x 7 (V) um (7 um pitch)
Photo Array Length		57.344 mm		28.672 mm		14.336 mm	
Total Data Rate	Camera Link Full	85MHz x 8 TAP	680 MHz				
		80MHz x 8 TAP	640 MHz				
		50MHz x 8 TAP	400 MHz				
	Camera Link Medium	85MHz x 4 TAP	340 MHz				
		80MHz x 4 TAP	320 MHz				
		50MHz x 4 TAP	200 MHz				
	Camera Link Base	85MHz x 2 TAP	170 MHz				
		80MHz x 2 TAP	160 MHz				
		50MHz x 2 TAP	100 MHz				
Maximum Line Rate	Camera Link Full	85MHz x 8 TAP	40kHz	80kHz			
		80MHz x 8 TAP	38.5kHz	75kHz			
		50MHz x 8 TAP	24kHz	47kHz			
	Camera Link Medium	85MHz x 4 TAP	20.5kHz	40kHz	80kHz		
		80MHz x 4 TAP	19kHz	38kHz	75kHz		
		50MHz x 4 TAP	12kHz	24kHz	47kHz		
	Camera Link Base	85MHz x 2 TAP	10kHz	20kHz	40kHz	80kHz	
		80MHz x 2 TAP	9.5kHz	19kHz	38kHz	75kHz	
		50MHz x 2 TAP	6kHz	12kHz	24kHz	47kHz	
Video Output	Camera Link Full	8 bit					
	Camera Link Medium	8 bit / 10 bit					
	Camera Link Base	8 bit / 10 bit					
Power	Input Voltage	+12 Vdc to +24 Vdc					
	Consumption	7.2W (TYP)	4.3W (TYP)		2.8W (TYP)		
Communication		RS232 via Camera Link connector					
Functions		Anti-Blooming High Speed Exposure Control External Trigger Control Field Flat Correction (FFC)					

Optical Specifications

Product	FS-B16KU35CL	FS-B8KU7CL	FS-B8KU35CL	FS-B4KU7CL	FS-B4KU35CL	FS-B2KU7CL
Fill Factor	100%					
Responsivity (except opck=11) gbdt=1	9DN/nj/cm2 (@8bit)	19DN/nj/cm2 (@8bit)	9DN/nj/cm2 (@8bit)	19DN/nj/cm2 (@8bit)	9DN/nj/cm2 (@8bit)	19DN/nj/cm2 (@8bit)
Responsivity (except opck=11) gbdt=0	38DN/nj/cm2 (@8bit)	77DN/nj/cm2 (@8bit)	38DN/nj/cm2 (@8bit)	77DN/nj/cm2 (@8bit)	38DN/nj/cm2 (@8bit)	77DN/nj/cm2 (@8bit)
Responsivity (opck=11) gbdt=1	19DN/nj/cm2 (@8bit)	38DN/nj/cm2 (@8bit)	19DN/nj/cm2 (@8bit)	38DN/nj/cm2 (@8bit)	19DN/nj/cm2 (@8bit)	38DN/nj/cm2 (@8bit)
Responsivity (opck=11) gbdt=0	77DN/nj/cm2 (@8bit)	155Dn/nj/cm2 (@8bit)	77DN/nj/cm2 (@8bit)	155Dn/nj/cm2 (@8bit)	77DN/nj/cm2 (@8bit)	155Dn/nj/cm2 (@8bit)

Mechanical Specifications

Product	FS-B16KU35CL	FS-B8KU7CL	FS-B8KU35CL	FS-B4KU7CL	FS-B4KU35CL	FS-B2KU7CL
Dimensions	80 (W) x 100 (H) x 38.1 (D) mm (excluding connector)		56 (W) x 58 (H) x 26.5 (D) mm			
Lens Mount	M72, P=0.75 mm		F Mount		F Mount, C Mount	
Weight	Approx. 453 g		Approx. 250g			
Interface Connectors	Camera Link connector (MDR) x 2 Power connector (6pin connector)					

Environmental Specifications

Product	FS-B16KU35CL	FS-B8KU7CL	FS-B8KU35CL	FS-B4KU7CL	FS-B4KU35CL	FS-B2KU7CL
RoHS	RoHS compliant					
Operating Temperature	0 to 40 deg. C					
Storage Temperature	-30 to 65 deg. C					

II. Product Numbering

Product Number:

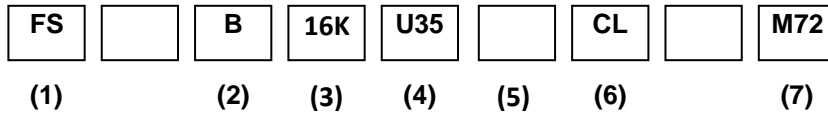

- (1) Series
- (2) BW / Color
 - B: Black and White
 - C: Color
- (3) Number of pixels
 - 16: 16K
 - 8: 8K
 - 4: 4K
 - 2: 2K
- (4) Pixel Size
 - U14: 14um
 - U35: 35um
 - U7: 7um
- (5) Line Number
 - None: 1 line (single)
 - D: 2 lines (dual)
 - Q: 4 lines (Quad)
- (6) Output type
 - CL: Camera link
 - GE: GigE Vision
 - CX: CoaXPress
- (7) Mount type
 - C: C mount
 - F: F mount
 - M72: M72 mount

Order Number

FS-B16KU35CL-M72
FS-B8KU7CL-M72
FS-B8KU35CL-F
FS-B4KU7CL-F
FS-B4KU35CL-F
FS-B2KU7CL-F
FS-B2KU7CL-C

III. Connector Specifications

A. FS-B2KU7CL

C. Power connector

LED

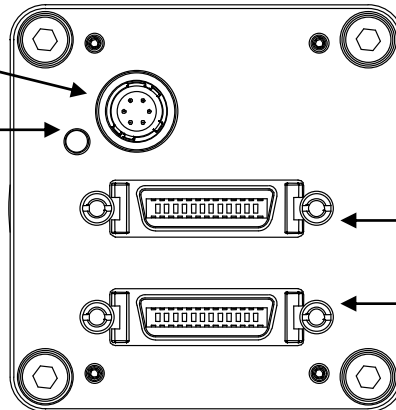

B. Don't use

A. Camera Link (Base)

A. Camera Link connector (Base):

B. Don't Use

C. Power Connector

This connector is for 12Vdc power input.

The RED LED light indicates that the camera is powered-on.

MDR Receptacle (3M)

HR10A-7R-6PB (Hirose)

B. FS-B8KU35CL, FS-B4KU7CL, FS-B4KU35CL

C. Power connector

LED

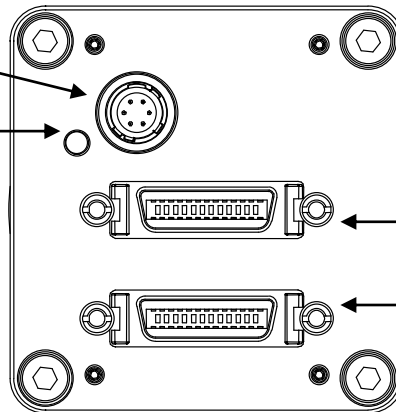

B. Camera Link (Full/Medium)

A. Camera Link (Base)

A. Camera Link connector (Base):

B. Camera Link connector (Medium/Full):

C. Power Connector

This connector is for 12Vdc power input.

The RED LED light indicates that the camera is powered-on.

MDR Receptacle (3M)

MDR Receptacle (3M)

HR10A-7R-6PB (Hirose)

C. FS-B8KU7CL, FS-B16KU35CL

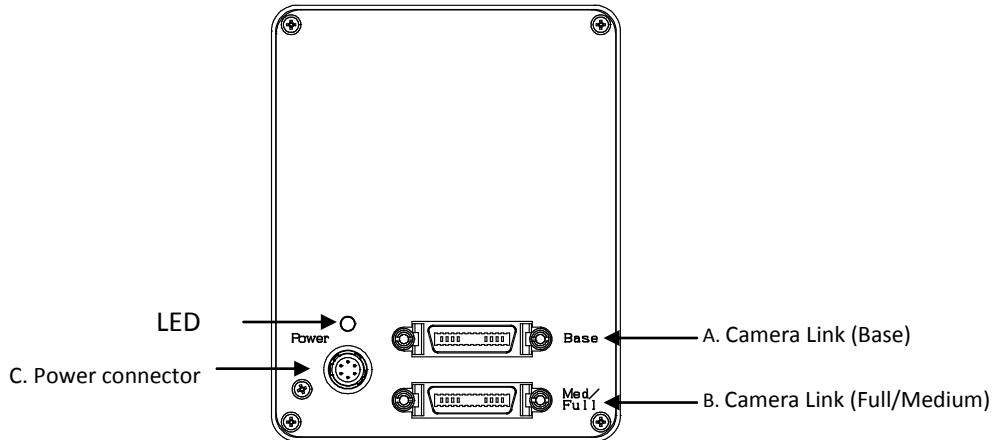

A. Camera Link connector (Base):

B. Camera Link connector (Medium/Full):

C. Power Connector

MDR Receptacle (3M)

MDR Receptacle (3M)

HR10A-7R-6PB (Hirose)

This connector is for 12Vdc power input.

The RED LED light indicates that the camera is powered-on.

D. Pin Assignment of the Connectors

1. Camera Link connector (Base): MDR Receptacle (3M)

Pin No.	Signal name	Pin No.	Signal name
1	GND	14	GND
2	X0-	15	X0+
3	X1-	16	X1+
4	X2-	17	X2+
5	Xclk-	18	Xclk+
6	X3-	19	X3+
7	SerTC+	20	SerTC-
8	SerTFG-	21	SerTFG+
9	CC1- (for the external sync signal input)	22	CC1+ (for the external sync signal input)
10	CC2+	23	CC2-
11	CC3-	24	CC3+
12	CC4+	25	CC4-
13	GND	26	GND

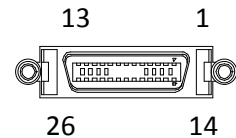

2. Camera Link connector (Medium): MDR Receptacle (3M)

Pin No.	Signal name	Pin No.	Signal name
1	GND	14	GND
2	Y0-	15	Y0+
3	Y1-	16	Y1+
4	Y2-	17	Y2+
5	Yclk-	18	Yclk+
6	Y3-	19	Y3+
7	100 Ohm terminated	20	100 Ohm terminated
8	Z0-	21	Z0+
9	Z1-	22	Z1+
10	Z2-	23	Z2+
11	Zclk-	24	Zclk+
12	Z3-	25	Z3+
13	GND	26	GND

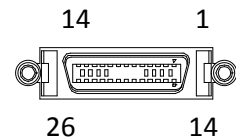

signal name	I/O	explanation
CC1	I	Ext TRG. Refer to section 5.
CC2	-	Spare
CC3	-	Spare
CC4	-	Spare
SerTC	I	Serial communication from the frame grabber.
SerTFG	O	Serial communication to the frame grabber.

3. Power Connector: HR10A-7R-6PB (Hirose or equivalent) (Cable connector: HR10A-7P-6S or equivalent)

Pin No.	Signal name	IN/OUT	Voltage
1	+12 V	IN	+12 V
2	+12 V	IN	+12 V
3	+12 V	IN	+12 V
4	GND		
5	GND		
6	GND		

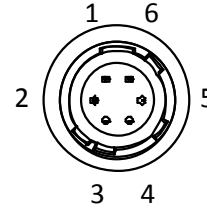

E. Bit Assignment

1. "Full Configuration"

Base connector			
Port/bit	8-bit x 8	Port/bit	8-bit x8
Port A0	A0	Port C0	C0
Port A1	A1	Port C1	C1
Port A2	A2	Port C2	C2
Port A3	A3	Port C3	C3
Port A4	A4	Port C4	C4
Port A5	A5	Port C5	C5
Port A6	A6	Port C6	C6
Port A7	A7	Port C7	C7
Port B0	B0		
Port B1	B1		
Port B2	B2		
Port B3	B3		
Port B4	B4		
Port B5	B5		
Port B6	B6		
Port B7	B7		

Full connector					
Port/bit	8-bit x 8	Port/bit	8-bit x8	Port/bit	8-bit x8
Port D0	D0	Port F0	F0	Port H0	H0
Port D1	D1	Port F1	F1	Port H1	H1
Port D2	D2	Port F2	F2	Port H2	H2
Port D3	D3	Port F3	F3	Port H3	H3
Port D4	D4	Port F4	F4	Port H4	H4
Port D5	D5	Port F5	F5	Port H5	H5
Port D6	D6	Port F6	F6	Port H6	H6
Port D7	D7	Port F7	F7	Port H7	H7
Port E0	E0	Port G0	G0		
Port E1	E1	Port G1	G1		
Port E2	E2	Port G2	G2		
Port E3	E3	Port G3	G3		
Port E4	E4	Port G4	G4		
Port E5	E5	Port G5	G5		
Port E6	E6	Port G6	G6		
Port E7	E7	Port G7	G7		

2. "Medium Configuration"

10 bit mode

Base connector			
Port/bit	10-bit x 4taps	Port/bit	10-bit x 4taps
Port A0	A0	Port C0	B0
Port A1	A1	Port C1	B1
Port A2	A2	Port C2	B2
Port A3	A3	Port C3	B3
Port A4	A4	Port C4	B4
Port A5	A5	Port C5	B5
Port A6	A6	Port C6	B6
Port A7	A7	Port C7	B7
Port B0	A8		
Port B1	A9		
Port B2	nc		
Port B3	nc		
Port B4	B8		
Port B5	B9		
Port B6	nc		
Port B7	nc		

Medium connector			
Port/bit	10-bit x 4taps	Port/bit	10-bit x 4taps
Port D0	D0	Port F0	C8
Port D1	D1	Port F1	C9
Port D2	D2	Port F2	nc
Port D3	D3	Port F3	nc
Port D4	D4	Port F4	D8
Port D5	D5	Port F5	D9
Port D6	D6	Port F6	nc
Port D7	D7	Port F7	nc
Port E0	C0		
Port E1	C1		
Port E2	C2		
Port E3	C3		
Port E4	C4		
Port E5	C5		
Port E6	C6		
Port E7	C7		

8 bit mode

Base connector			
Port/bit	8-bit x 4taps	Port/bit	8-bit x 4taps
Port A0	A0	Port C0	C0
Port A1	A1	Port C1	C1
Port A2	A2	Port C2	C2
Port A3	A3	Port C3	C3
Port A4	A4	Port C4	C4
Port A5	A5	Port C5	C5
Port A6	A6	Port C6	C6
Port A7	A7	Port C7	C7
Port B0	B0		
Port B1	B1		
Port B2	B2		
Port B3	B3		
Port B4	B4		
Port B5	B5		
Port B6	B6		
Port B7	B7		

Medium connector			
Port/bit	8-bit x 4taps	Port/bit	8-bit x 4taps
Port D0	D0	Port F0	nc
Port D1	D1	Port F1	nc
Port D2	D2	Port F2	nc
Port D3	D3	Port F3	nc
Port D4	D4	Port F4	nc
Port D5	D5	Port F5	nc
Port D6	D6	Port F6	nc
Port D7	D7	Port F7	nc
Port E0	nc		
Port E1	nc		
Port E2	nc		
Port E3	nc		
Port E4	nc		
Port E5	nc		
Port E6	nc		
Port E7	nc		

3. "Base Configuration"

10 bit mode

Base connector			
Port/bit	10-bit x 2taps	Port/bit	10-bit x 2taps
Port A0	A0	Port C0	B0
Port A1	A1	Port C1	B1
Port A2	A2	Port C2	B2
Port A3	A3	Port C3	B3
Port A4	A4	Port C4	B4
Port A5	A5	Port C5	B5
Port A6	A6	Port C6	B6
Port A7	A7	Port C7	B7
Port B0	A8		
Port B1	A9		
Port B2	nc		
Port B3	nc		
Port B4	B8		
Port B5	B9		
Port B6	nc		
Port B7	nc		

8 bit mode

Base connector			
Port/bit	8-bit x 2taps	Port/bit	8-bit x 2taps
Port A0	A0	Port C0	nc
Port A1	A1	Port C1	nc
Port A2	A2	Port C2	nc
Port A3	A3	Port C3	nc
Port A4	A4	Port C4	nc
Port A5	A5	Port C5	nc
Port A6	A6	Port C6	nc
Port A7	A7	Port C7	nc
Port B0	B0		
Port B1	B1		
Port B2	B2		
Port B3	B3		
Port B4	B4		
Port B5	B5		
Port B6	B6		
Port B7	B7		

IV. Timing Chart

Caution: Camera does not accept any commands without sync signal. When External Trigger Mode (limd=1) is used through the Hyper Terminal, please send the commands on Internal Sync mode. And send the next command after receiving OK.

A. Exposure Time

EXT LINE

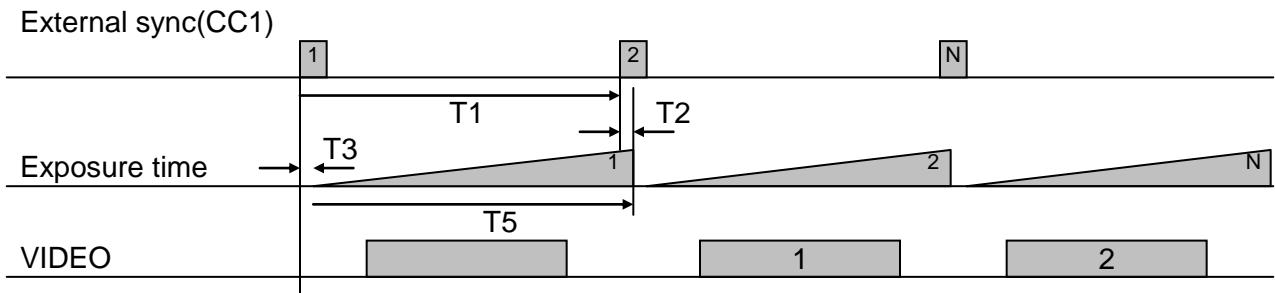

EXT FIX MODE

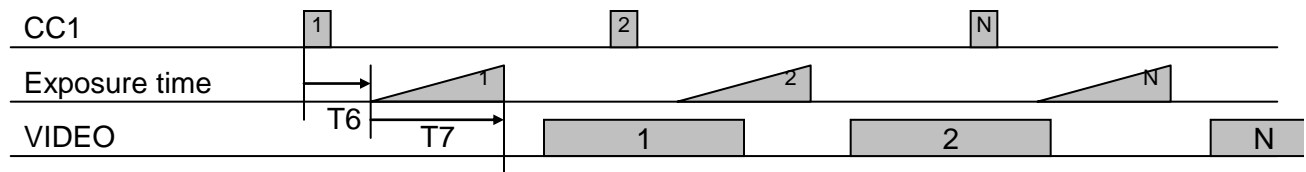

PULSE MODE

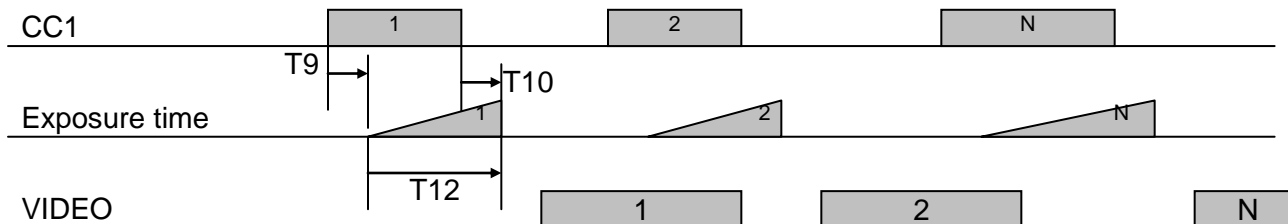

INTERNAL MODE

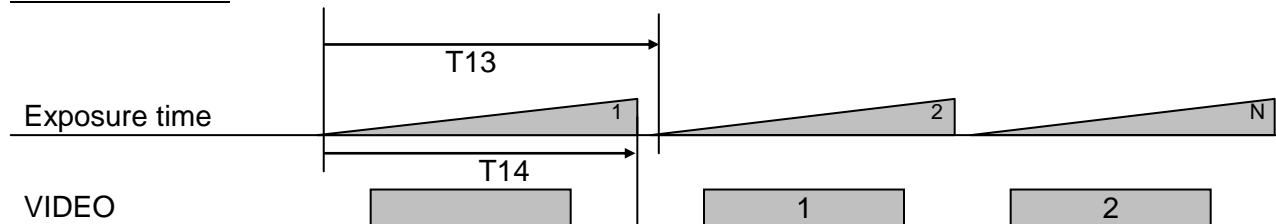

Label	Description	Value [us]
T1	Line interval	External sync : CC1 line period
T2	Sync rise to exposure end	$(6 \times B) + 1$
T3	Sync rise to exposure start	B16K : $(18 \times B) + 2$ Except B16K: $(18 \times B) + 1$
T5	Exposure time(EXT_LINE)	B16K : $T1 - (12 \times B) - 3$ Except B16K : $T1 - (12 \times B) - 2$
T6	CC1 rise to exposure start (EXT_FIX)	$(6 \times B) + 2$
T7	Exposure time (EXT_FIX)	B16K : $((\text{intu} \times 256 + \text{intl}) \times C) + 5$ Except B16K : $((\text{intu} \times 256 + \text{intl}) \times C) + 2$ min setting : intu = 0, intl = 0 Maximum Exposure Time: Line period - 3us
T9	CC1 rise to exposure start PULSE)	$(5 \times B) + 2$
T10	CC1 fall to exposure end PULSE)	$(5 \times B) + 1$
T12	Exposure time (PULSE)	Pulse width of CC1(High) – 1
T13	Line interval (INTERNAL)	$((\text{intu} \times 256 + \text{intl}) \times C) + A$ A : Minimum line period
T14	Exposure time (INTERNAL)	B16K : $T13 - 3 - (12 \times B)$ Except B16K : $T13 - 2 - (12 \times B)$

*Parameter A, B and C are different for each camera model. Please refer to the actual number on the table below.

**Intu, intl and opck are camera control ASCII commands. For details please refer to the Command Descriptions.

The min and max of T12 follows.

The min of T12=3us

The max of T12= the line period – 2us

A: Minimum line period [us]

opck	FS-B16KU35CL	FS-B8KU35CL, FS-B8KU7CL	FS-B4KU7CL, FS-B4KU35CL	FS-B2KU7CL
0	25.4 us	13.2 us	13.2 us	13.2 us
1	41.6 us	21.1 us	21.1 us	21.1 us
2	48.6 us	24.5 us	24.5 us	-
3	82.6 us	41.6 us	41.6 us	-
4	96.8 us	48.6 us	-	-
5	164.5 us	82.6 us	-	-
8	26 us	13.2 us	13.2 us	13.2 us
9	51.6 us	25 us	25 us	-
10	102.8 us	51.6 us	-	-
11	25 us	12.5 us	12.5 us	12.5 us
23	25.4 us	13.2 us	-	-
24	26 us	13.2 us	-	-
25	41.6 us	21.1 us	-	-
26	25.4 us	13.2 us	13.2 us	13.2 us
27	26 us	13.2 us	13.2 us	13.2 us
28	41.6	21.1 us	21.1 us	21.1 us

B: CLK period

Model	Value [us]
FS-B16KU35CL	0.0235
Except for FS-B16KU35CL	0.0117

C: Amount of change time per step

Model	Value [us]
FS-B16KU35CL	0.4
Except for FS-B16KU35CL	0.2

V. Output mode

A. FS-B2KU7CL

Four rate modes can be selected using command: opck.

opck	Maximum line rate	Total data rate	Camera Link Configuration
0	75kHz	170MHz (85MHzx2TAP)	Base
1	47kHz	100MHz (50MHzx2TAP)	Base
2-7	Don't use		
8	75kHz	160MHz (80MHzx2TAP)	Base
9-10	Don't use		
11	80kHz	170MHz (85MHzx2TAP)	Base
12-25	Don't use		
26	75kHz	170MHz (85MHzx2TAP)	AOI mode (Base)
27	75kHz	160MHz (80MHzx2TAP)	AOI mode (Base)
28	47kHz	100MHz (50MHzx2TAP)	AOI mode (Base)
29-255	Don't use		

1. Output Timing "Base"



2. Output Timing "AOI Mode (BASE)"

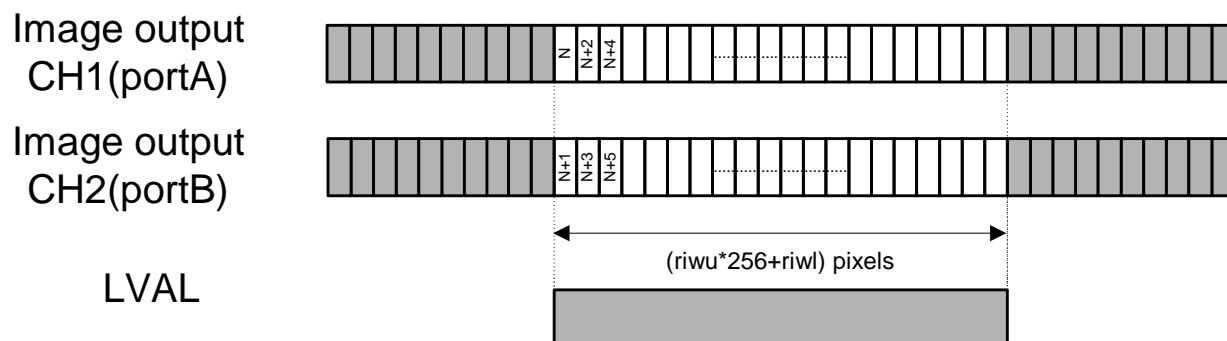

$$N = (risu * 256 + risl) * 2 + 1$$

B. FS-B4KU35CL

Seven Data rate modes can be selected using command: opck.

opck	Maximum line rate	Total data rate	Camera Link Configuration
0	75kHz	340MHz (85MHzx4TAP)	Medium
1	47kHz	200MHz (50MHzx4TAP)	Medium
2	40kHz	170MHz (85MHzx2TAP)	Base
3	24kHz	100MHz (50MHzx2TAP)	Base
4-7	Don't use		
8	75kHz	320MHz (80MHzx4TAP)	Medium
9	38kHz	160MHz (80MHzx2TAP)	Base
10	Don't use		
11	80kHz	340MHz (85MHzx4TAP)	Medium
12-25	Don't use		
26	75kHz	170MHz (85MHzx2TAP)	AOI mode (Base)
27	75kHz	160MHz (80MHzx2TAP)	AOI mode (Base)
28	47kHz	100MHz (50MHzx2TAP)	AOI mode (Base)
29-255	Don't use		

1. Output Timing “Medium configuration”

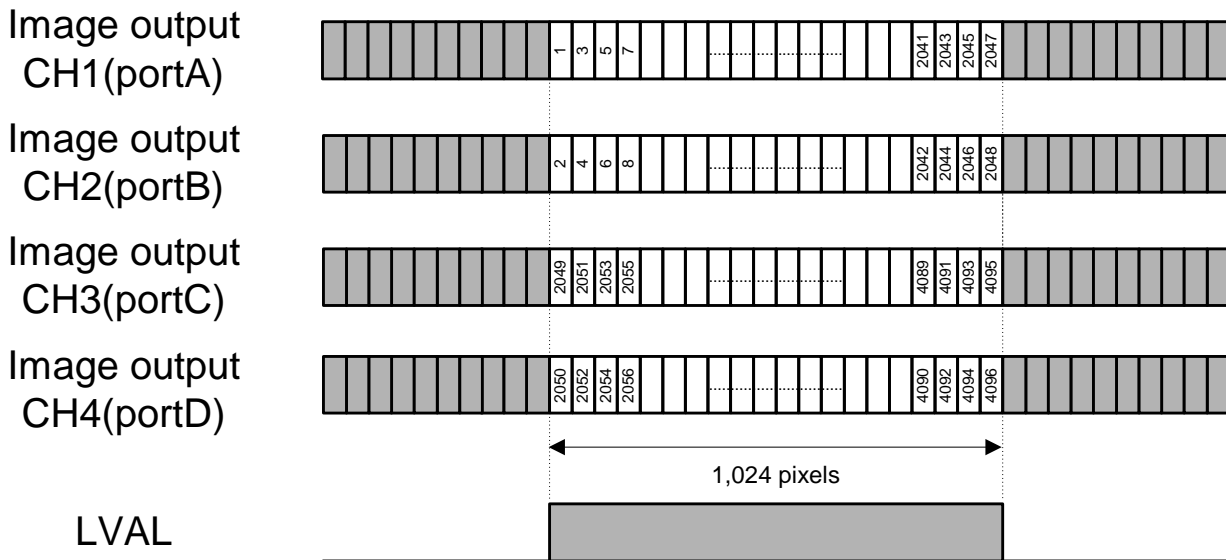

2. Output Timing “Base configuration”

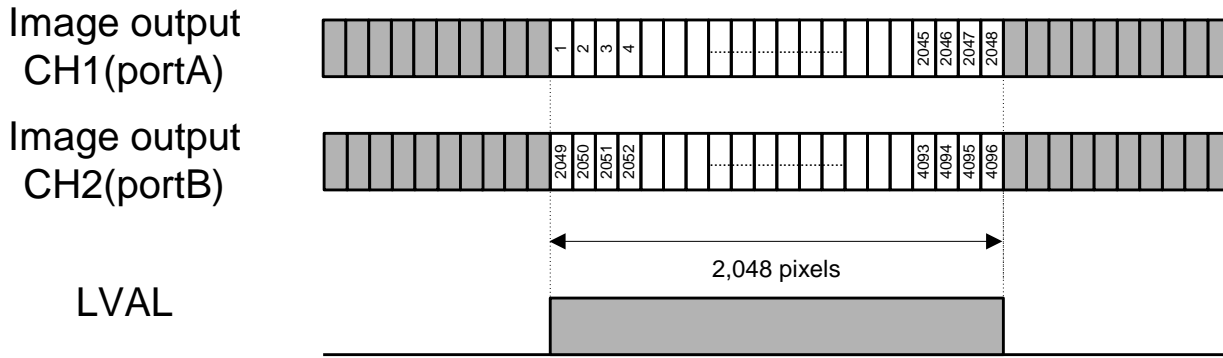

3. Output Timing “AOI Mode (Base)”

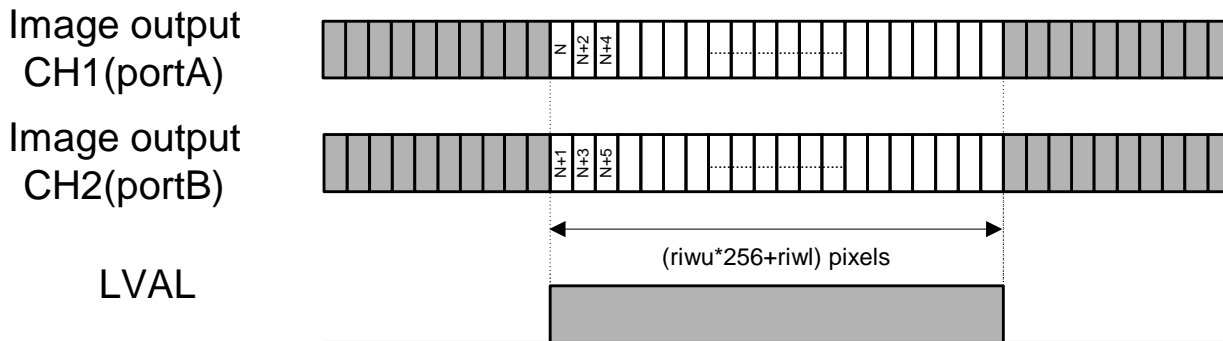

Product number	The start pixel output
FS-B4KU35CL	$N = (risu \cdot 256 + risl) \cdot 4 + 1$
FS-B4KU7CL	$N = (risu \cdot 256 + risl) \cdot 2 + 1$

C. FS-B8KU35CL, FS-B8KU7CL

You can change ten modes of data rate by opck command.

opck	Maximum line rate	Total data rate	Camera Link Configuration
0	75kHz	680MHz (85MHzx8TAP)	Full Format1
1	47kHz	400MHz (50MHzx8TAP)	Full Format1
2	40kHz	340MHz (85MHzx4TAP)	Medium
3	24kHz	200MHz (50MHzx4TAP)	Medium
4	20kHz	170MHz (85MHzx2TAP)	Base
5	12kHz	100MHz (50MHzx2TAP)	Base
6-7	Don't use		
8	75kHz	640MHz (80MHzx8TAP)	Full Format1
9	38kHz	320MHz (80MHzx4TAP)	Medium
10	19kHz	160MHz (80MHzx2TAP)	Base
11	80kHz	680MHz (85MHzx8TAP)	Full Format1
12-22	Don't use		
23	75kHz	680MHz (85MHzx8TAP)	Full Format2
24	75kHz	640MHz (80MHzx8TAP)	Full Format2
25	47kHz	400MHz (50MHzx8TAP)	Full Format2
26	75kHz	170MHz (85MHzx2TAP)	AOI mode (Base)
27	75kHz	160MHz (80MHzx2TAP)	AOI mode (Base)
28	47kHz	100MHz (50MHzx2TAP)	AOI mode (Base)

1. Output Timing "Full Configuration Format1"

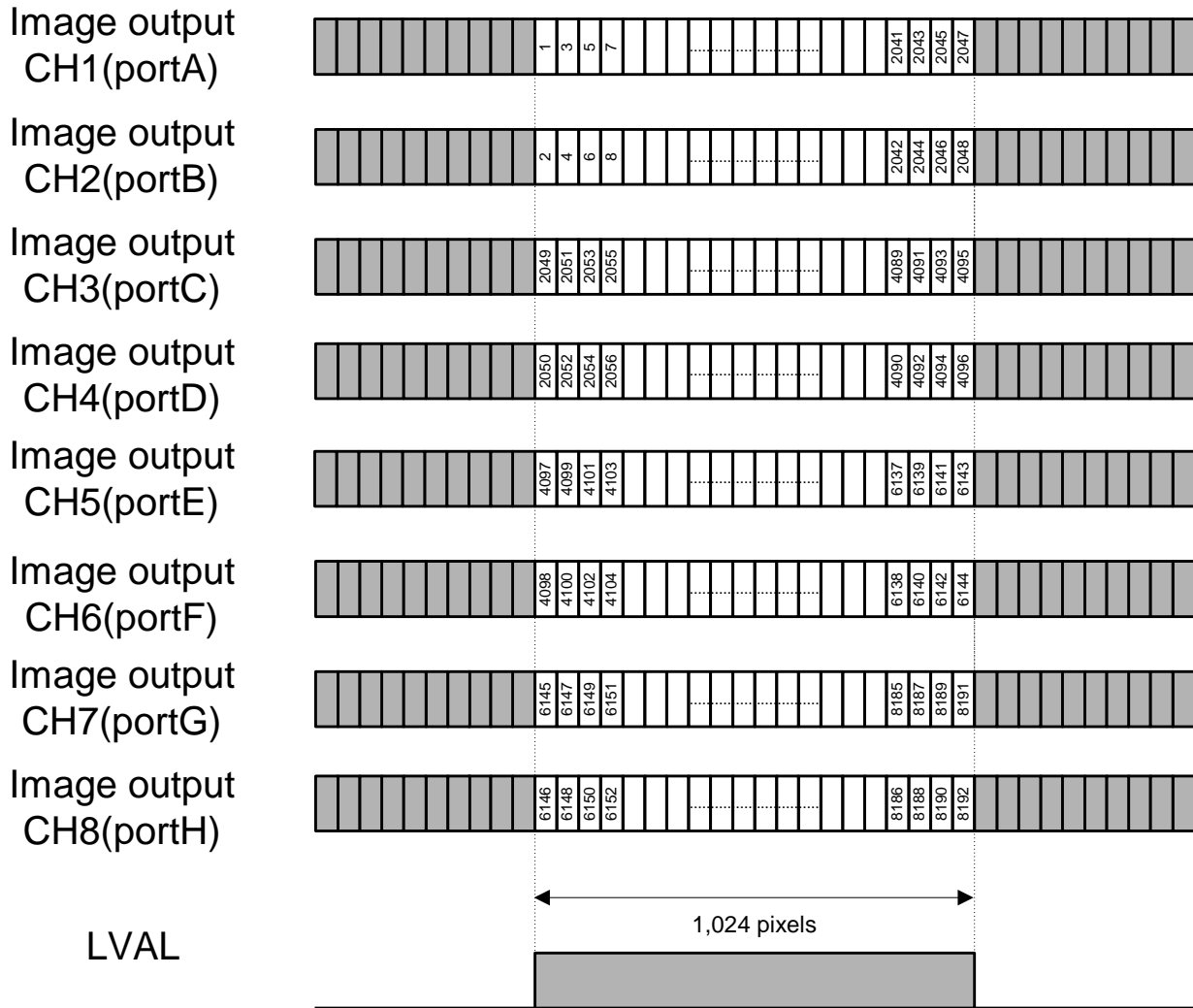

2. Output Timing "Full Configuration Format2"

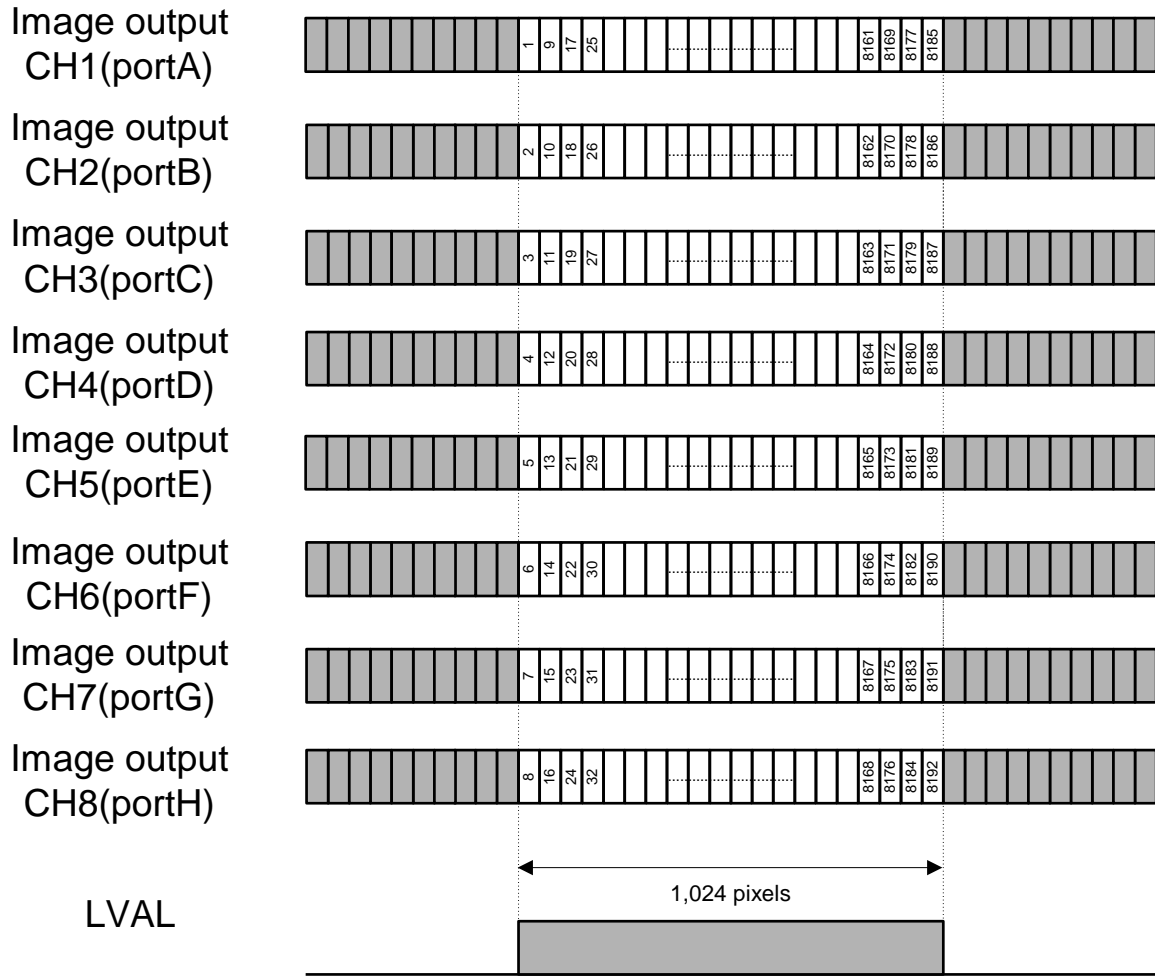

3. Output Timing "Medium Configuration"

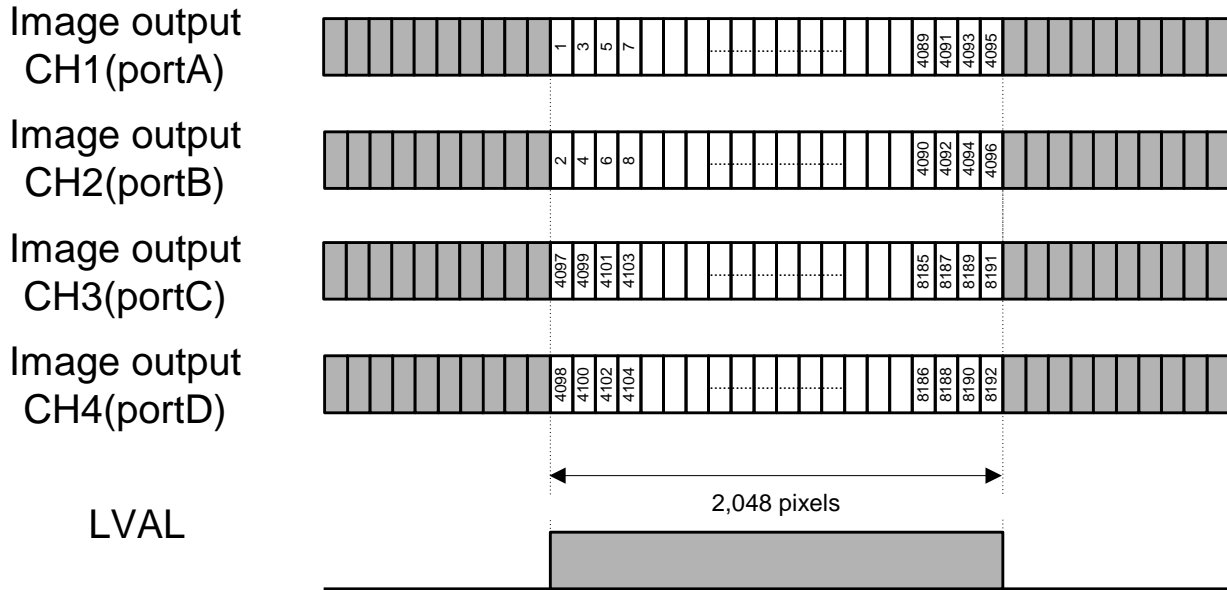

4. Output Timing "Base Configuration"

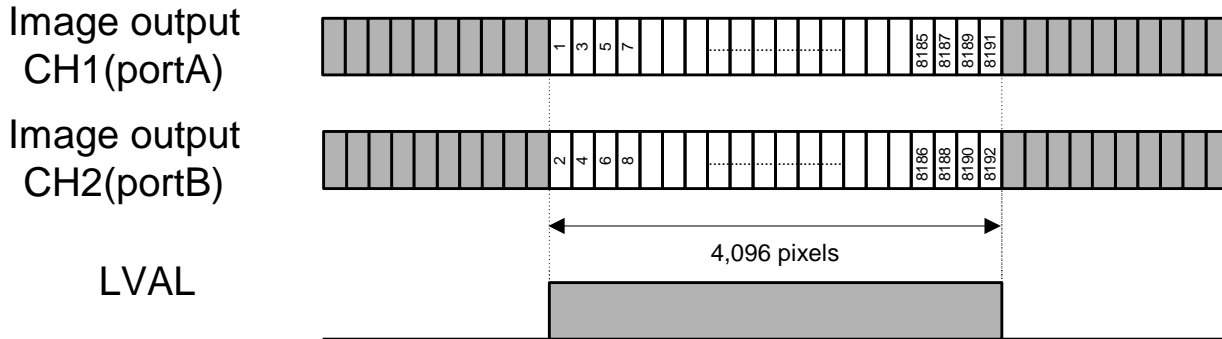

5. Output Timing "AOI Mode (Base)"

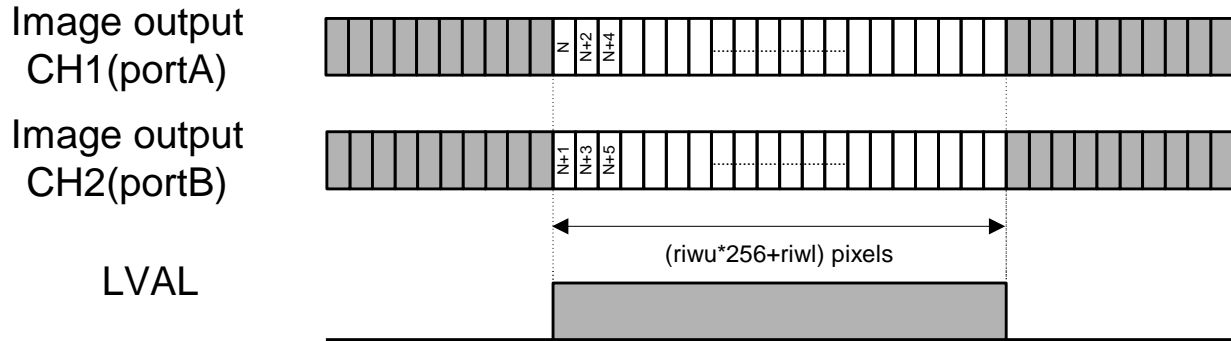

Product number	The start pixel output
FS-B8KU35CL	$N = (risu \cdot 256 + risl) \cdot 4 + 1$
FS-B8KU7CL	$N = (risu \cdot 256 + risl) \cdot 2 + 1$

D. FS-B16U35CL

You can change nine modes of data rate by opck command.

opck	Maximum line rate	Total data rate	Camera Link Configuration
0	39kHz	680MHz (85MHzx8TAP)	Full Format1
1	24kHz	400MHz (50MHzx8TAP)	Full Format1
2	20.5kHz	340MHz (85MHzx4TAP)	Medium
3	12kHz	200MHz (50MHzx4TAP)	Medium
4	10kHz	170MHz (85MHzx2TAP)	Base
5	6kHz	100MHz (50MHzx2TAP)	Base
6-7	Don't use		
8	38.5kHz	640MHz (80MHzx8TAP)	Full Format1
9	19kHz	320MHz (80MHzx4TAP)	Medium
10	9.5kHz	160MHz (80MHzx2TAP)	Base
11	40kHz	680MHz (85MHzx8TAP)	Full Format1
12-22	Don't use		
23	39kHz	680MHz (85MHzx8TAP)	Full Format2
24	38.5kHz	640MHz (80MHzx8TAP)	Full Format2
25	24kHz	400MHz (50MHzx8TAP)	Full Format2
26	40kHz	170MHz (85MHzx2TAP)	AOI mode (Base)
27	38.5kHz	160MHz (80MHzx2TAP)	AOI mode (Base)
28	24kHz	100MHz (50MHzx2TAP)	AOI mode (Base)
29-255	Don't use		

1. Output Timing "Full Configuration Format1"

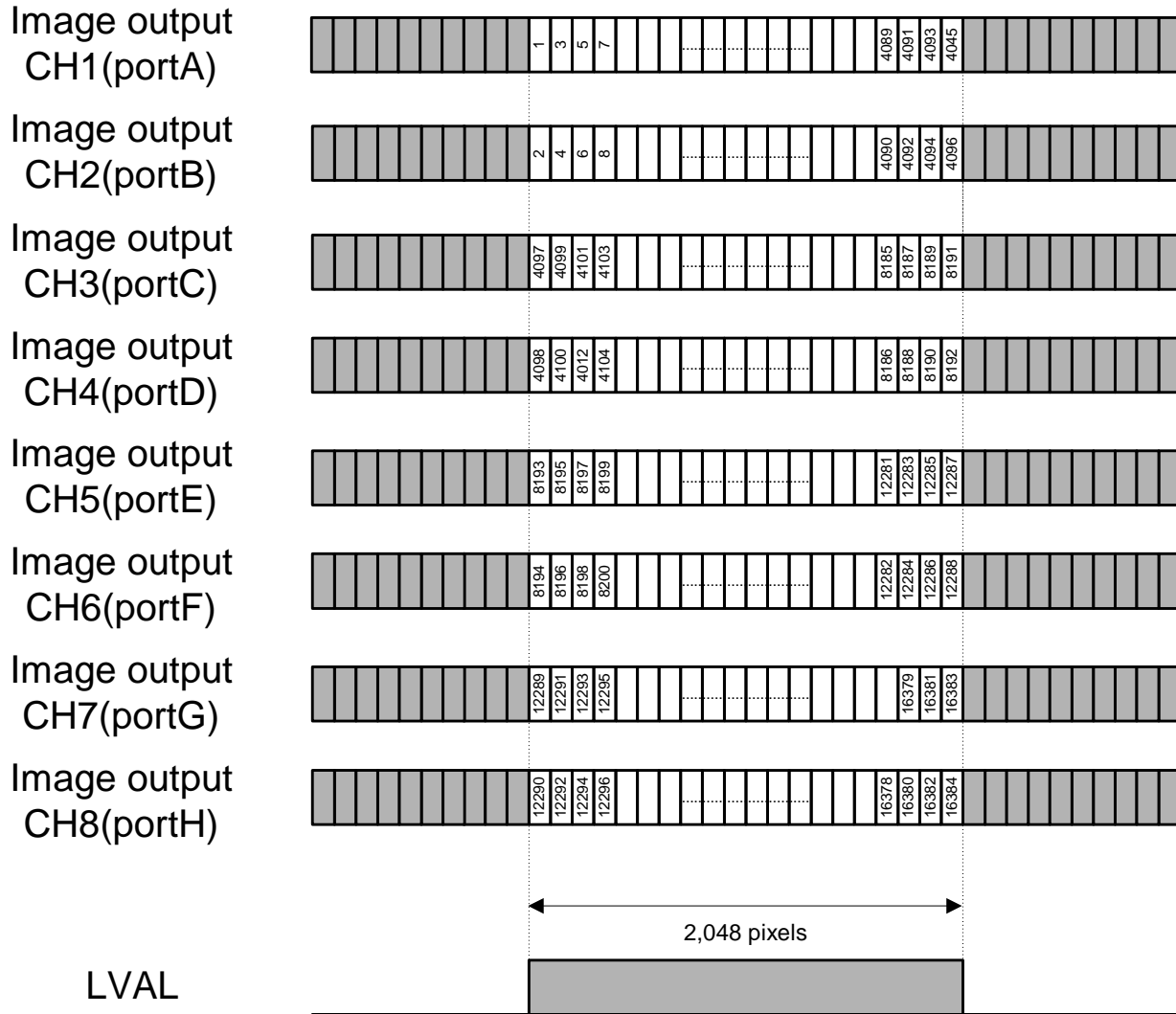

2. Output Timing "Full configuration Format2"

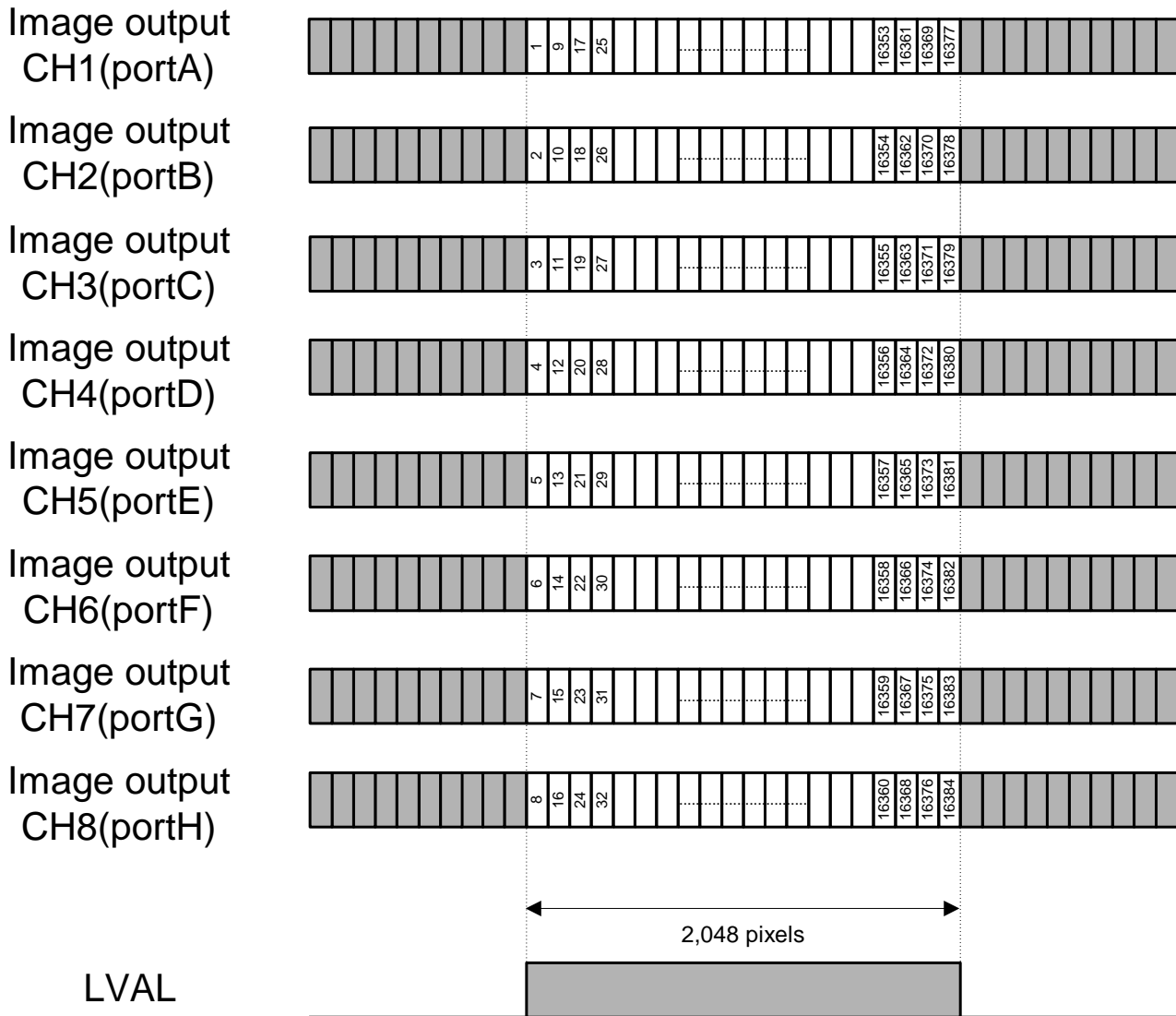

3. Output Timing "Medium Configuration"

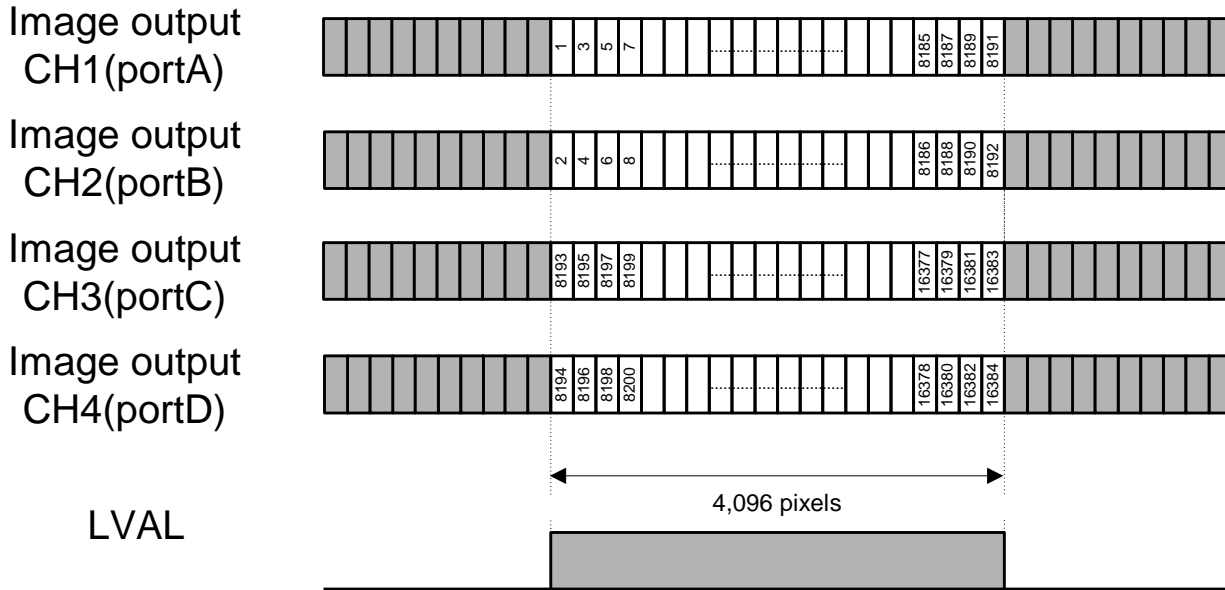

4. Output Timing "Base Configuration"

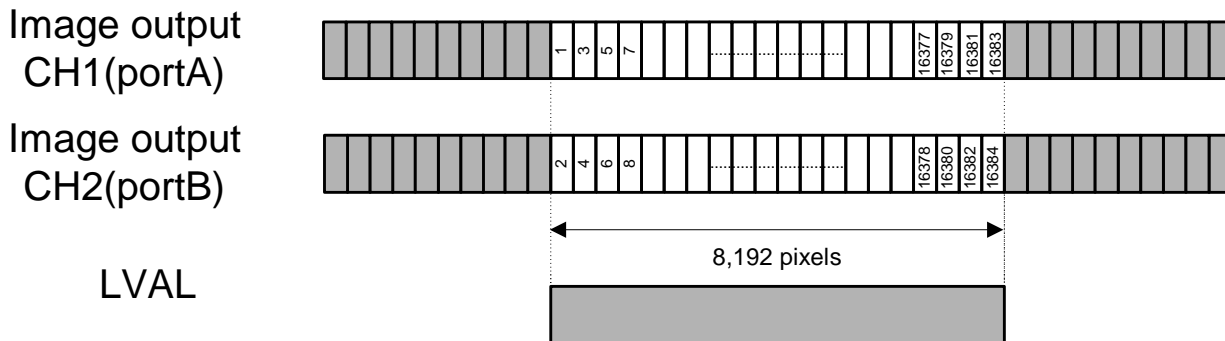

5. Output Timing "AOI Mode (Base)"

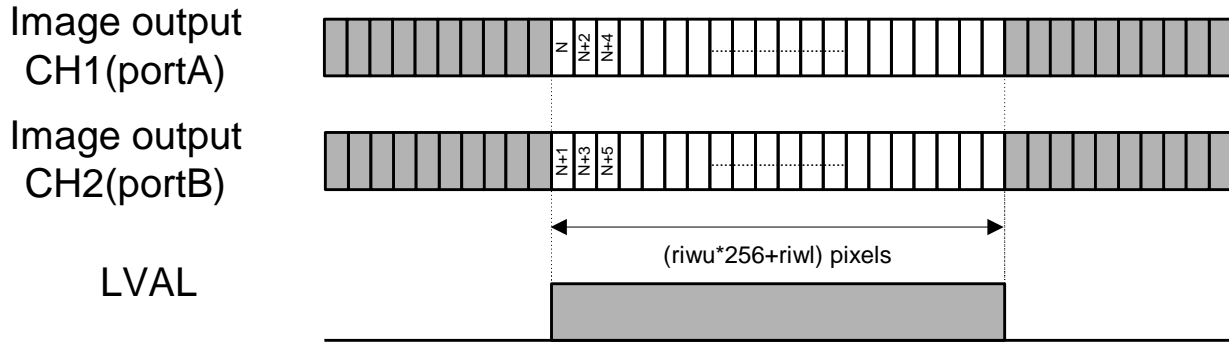

$$N = (risu * 256 + risl) * 2 + 1$$

VI. Communication Specifications

-Communication format

Baud Rate: 9600bps
Data Length: 8 bit
Start Bit: 1 bit
Stop Bit: 1 bit
Parity: None
Xob/Xoff Control: None

-Communication

usid?<CR> Reads the camera ID from the Camera
limd=1<CR> Sets the external sync system to the camera

-Glossary

[] Omissible
<CR> Carriage Return

-Notes

1. The command name has to be lower-case. Upper case characters are invalid.
2. The command has to be a one byte character. Double byte characters are invalid.
3. A blank space (spacebar) is invalid.
4. The newline code is indicated by "CR(0x0D)".
LF(0x0A) and CR + LF are usable for the newline code.
However, the newline code at the returning command is always as "CR".
5. Retyping the command is necessary when using the hyper terminal and a command input error is received.
(The command corrects by the cursor moving is invalid)
6. Descriptions of exceptional cases:
-"NG" is returned when a non-exist command is input or an input error is received.

e.g. A command input error (Gain A level number is not designated)

Input command: ga01=96
Returned command: NG

e.g. A none-exist command is input

Input command: ff
Returned command: NG

-"NE" is returned when a numeric value input error is received.

e.g. The numeric value input error (Input value is out of the setting range)

Input command: galv=96
Returned command: NE

e.g. The numeric value input error (Input value is out of the setting range)

Input command: ga01=2000
Returned command: NE

All commands are in lower-case. The default values are underlined.

	Command Name	Format	Argument	Return value	Explanation
User	Get ID (Note.1)	usid[?]<CR>	N/A	ID (Default: <u>0</u>)	Get the camera ID (For multiple camera management)
	Set ID (Note.1)	usid=N<CR>	N: 0-255	OK	Set the camera ID (For multiple camera management)
Sync Selection	Get Sync	limd[?]<CR>	N/A	1: Ext Sync 2: Int Sync	Get the sync system of the camera
	Set Sync	limd=N<CR>	N=1: Ext Sync N=2: Int Sync	OK	Set the sync system of the camera CC1 is the external sync pulse
Exposure control	Get Exposure Control	inmd[?]<CR>	N/A	0: Line cycle 1: Fixed Time Exposure 2: Pulse Width Exposure	Get the exposure control status
	Set Exposure Control	inmd=N<CR>	N=0: Line cycle N=1: Fixed Time Exposure N=2: Pulse Width Exposure	OK	Set the exposure control status
Exposure Time	Get Exposure Time	intu[?]<CR> intl[?]<CR>	N/A	1-255 (Default: <u>0</u>) 0-255 (Default: <u>0</u>)	Get the exposure time
	Set Exposure Time	intu=N<CR> intl=N<CR>	N=1-255 N=0-255	OK	Set the exposure time
Output Bit	Get width of output	opbt<CR>	N/A	8: 8bit 10: 10bit	Get width of video output.
	Set width of output	opbt=N<CR>	N=8: 8bit N=10: 10bit	OK	Set width of video output.
System	Check	cmck<CR>	N/A	OK	Communication test
	Save	cmsv<CR>	N/A	OK	Save settings to the EEPROM
	Load	cmld<CR>	N/A	OK	Load settings from the EEPROM
	Version	fivr<CR>	N/A	CPU Version	Get the version number of the program for the microcomputer control
	Model	cmmo<CR>	N/A	Model	Get the camera model
	Revision	fpvr<CR>	N/A	FPGA Revision	Get the version number of FPGA
	config	cmcf<CR>	N/A	(Data output)	Get the all current settings
	clear	cmcl<CR>	N/A	OK	Clear current command settings of EEPROM
	Command list	cmcm<CR>	N/A	command list	active command list
Data Rate control	Get Data Rate Mode	opck[?]<CR>	N/A	0-255 (Default: <u>0</u>)	Get Data Rate Mode
	Set Data Rate Mode	opck=N<CR>	0-255	OK	Set Data Rate Mode

Command Name	Format	Argument	Return value	Explanation
FFC Control Mode	ffmd=N<CR>	N=0: OFF	OK	Shade control mode value reference/setting
		N=1: ON		
		N=2: Data out (Note.2)		
		N=3: Data in (by pixel)		
		N=4: Data in (all)		
		N=5: Auto shade for gain		
		N=6: Auto shade for offset		
	ffmd[?]<CR>	N/A	0: OFF 1: ON 2: Data out (Note.2) 3: Data in (by pixel) 4: Data in (all) 5: Auto shade for gain 6: Auto shade for offset	
Select Gain/Offset	ffgo=N<CR>	N=0: OFF N=1: Gain N=2: Offset	OK	Setting target value reference/setting (Note.3)
	ffgo[?]<CR>	N/A		
			0: OFF 1: Gain 2: Offset	
Lower Pixel Address	ffpl=N<CR>	N: 0-255	OK	Correction target pixel (The lower rank address) value reference/setting (Note.4)
	ffpl[?]<CR>	N/A		
Upper Pixel Address	ffpu=N<CR>	N: 0-255	OK	Correction target pixel (The upper rank address) value reference/setting (Note.4)
	ffpu[?]<CR>	N/A		
FFC Coeff	ffdt=N<CR>	N: 0-255	OK	Set the upper 8bit data of FFC coefficients (12bit).
	ffdtl=N<CR>	N: 16-240	OK	Set the lower 4bit data of FFC coefficients(12bit) This value has to be a multiple of 16 The remainder of N divided by 16 is ignored
	ffdt[?]<CR>	N/A	0-255 (Default: 0)	Get the upper 8bit data of FFC coefficients (12bit)
	ffdtl[?]<CR>	N/A	16-240 (Default: 16)	Get the lower 4bit data of FFC coefficients(12bit). This value is multiple of 16
Black Level Target	ffto=N<CR>	N: 0-255	OK	Correction target level value reference/setting for black level (Note.4)
	ffto[?]<CR>	N/A		
Gray Level Target	fftg=N<CR>	N: 0-255	OK	Correction target level value reference/setting for gray level (Note.4)
	fftg[?]<CR>	N/A		
Set Data	ffds<CR>	N/A	OK	Set data
Get Selected Output	fful<CR>	N/A	0: upper 8 bits 1: lower 4 bits	Select upper 8 bits or lower 4 bits of the shade correction value to be put on the video output line when ffmd=4
Set Selected Output	fful=N<CR>	0: upper 8 bits 1: lower 4 bits	OK	
EEPROM Load From User Bank	ffld<CR>	N/A	OK	Load shade data (Gain and Offset) from EEPROM user bank
EEPROM Save To user Bank	ffsv<CR>	N/A	OK	Save shade data(Gain and Offset) to EEPROM user bank
EEPROM Load From Factory Bank	fflf<CR>	N/A	OK	Load shade data (Gain and Offset) from EEPROM factory bank
RAM clear	ffcg<CR>	Non	OK	Clear shade data(Gain) to 0
	ffco<CR>	Non	OK	Clear shade data(Offset) to 3200(12bit)

FFC

	Command Name	Format	Argument	Return value	Explanation
FFC	Get User Mode	ffum[?]<CR>	N/A	0:user mode OFF 1:user mode ON	User BANK mode ON/OFF ON: save/load FFC coefficient to User BANK
	Set User Mode	ffum=N<CR>	0:user mode OFF 1:user mode ON	OK	OFF: " Normal BANK
	Get FFC coefficient bank	ffsb[?]<CR>	N/A	0-7 (Default: 0)	Get User BANK
	Set FFC coefficient bank	ffsb=N<CR>	0-7 (Default: 0)	OK	Set User BANK
Test Pattern	Get Test Pattern	tsmd[?]<CR>	N/A	0: OFF 1: test pattern 1 2: test pattern 2 3: test pattern 3	Get test pattern mode
	Set Test Pattern	tsmd=N<CR>	N=0: OFF N=1: test pattern 1 N=2: test pattern 2 N=3: test pattern 3	OK	Set test pattern mode
Digital Gain	Get Gain A Data	gadt<CR>	N/A	0-255 (Default: 0)	Get Digital Gain Data
	Set Gain A Data	gadt=N<CR>	N: 0-255	OK	Set Digital Gain Data
Gain B	Get Gain B Mode	gbdt<CR>	N/A	0 or 1(Default: 0)	Get Gain B Mode
	Set Gain B Mode	gbdt=N<CR>	N=0: OFF N=1: ON	OK	Set Gain B Mode
Anti Blooming	Get Anti Blooming Mode	abmd<CR>	N/A	0 or 1(Default: 0)	Get Anti Blooming Mode
	Set Anti Blooming Mode	abmd=N<CR>	N=0: OFF N=1: ON	OK	Set Anti Blooming Mode
AOI	Get start pixel of AOI	risu<CR>	N/A	0-255 (Default: 0)	Get start pixel of AOI (The upper rank address)
		risl<CR>	N/A	0-255 (Default: 0)	Get start pixel of AOI (The lower rank address)
	Set start pixel of AOI	risu=N<CR>	N=0-255 (Default: 0)	OK	Set start pixel of AOI (The upper rank address)
		risl=N<CR>	N=0-255 (Default: 0)	OK	Set start pixel of AOI (The lower rank address)
	Get the length of LVAL	riwu<CR>	N/A	0-255 (Default: 4)	Get the length of LVAL (The upper rank)
		riwl<CR>	N/A	0-255 (Default: 0)	Get the length of LVAL (The lower rank)
Set the length of LVAL	riwu=N<CR>	N=0-255 (Default: 4)	OK	Set the length of LVAL (The upper rank)	
	riwl=N<CR>	N=0-255 (Default: 0)	OK	Set the length of LVAL (The lower rank)	

Note 1: The camera ID can be saved in the user area of the EEPROM, but cannot be cleared by a clear command.

Note 2: Gain or offset value (coeff) will be put on the video output instead of the image data.

Note 3: Gain or Offset must be set prior to "Set Data".

Note 4: Correction target pixel address = $ffpu \times 256 + ffpl$.

VII. Command Description

A. Sync / Exposure Control (limd / inmd)

limd: Change sync control mode.

Inmd: Change exposure control mode.

B. Sync and Exposure Mode

Four operating modes can be selected using limd in *Sync Selection* and inmd in *Exposure Control*.

inmd \ limd		1	2
		External	Internal
0	LINE	EXT_LINE	Internal
1	FIX	EXT_FIX	
2	PLS	Pulse	Don't use

1. EXT_LINE mode

SYNC: External Sync

EXPOSURE TIME: Line Cycle (Refer to III-A)

$$\text{Exposure time [us]} = \text{Line period} - (2 + (12 \times B))$$

B: CLK period (different by model)

Model	Value [us]
FS-B16KU35CL	0.0235
Except for FS-B16KU35CL	0.0117

2. EXT_FIX mode

SYNC: External Sync

EXPOSURE TIME: Programmable with intu and intl (refer to III-A)

$$\text{Exposure time [us]} = ((\text{intu} \times 256 + \text{intl}) \times C) + 2$$

C: Amount of change time per step

Model	Value [us]
FS-B16KU35CL	0.4
Except for FS-B16KU35CL	0.2

3. INTERNAL mode

SYNC: Internal Sync Only

EXPOSURE TIME: Line Cycle (Refer to III-A)

Exposure time [us] = ((intu x 256 + intl) x C) + A - (2 + (12 x B))

Line period [us] = ((intu x 256 +intl) x C) + A

A: Minimum line period (different by model).

opck	FS-B16KU35CL	FS-B8KU35CL, FS-B8KU7CL	FS-B4KU7CL, FS-B4KU35CL	FS-B2KU7CL
0	25 us	13.2 us	13.2 us	13.2 us
1	41.6 us	21.1 us	21.1 us	21.1 us
2	48.6 us	24.5 us	24.5 us	-
3	82.6 us	41.6 us	41.6 us	-
4	96.8 us	48.6 us	-	-
5	164.5 us	82.6 us	-	-
8	26 us	13.2 us	13.2 us	13.2 us
9	51.6 us	25 us	25 us	-
10	102.8 us	51.6 us	-	-
11	25 us	12.5 us	12.5 us	12.5 us
23	25.4 us	13.2 us	-	-
24	26 us	13.2 us	-	-
25	41.6 us	21.1 us	-	-
26	25.4 us	13.2 us	13.2 us	13.2 us
27	26 us	13.2 us	13.2 us	13.2 us
28	41.6	21.1 us	21.1 us	21.1 us

B: CLK period (different by model).

Model	Value [us]
FS-B16KU35CL	0.0235
Except for FS-B16KU35CL	0.0117

C: Amount of change time per step.

Model	Value [us]
FS-B16KU35CL	0.4
Except for FS-B16KU35CL	0.2

4. PULSE mode

SYNC: External Sync

EXPOSURE TIME: Pulse Width

Exposure time [us] = Pulse width of CC1 (High) - 1

C. Exposure Time Setting (intu / intl)

When the exposure control mode is programmable, set the exposure time. When sync control is Internal, exposure time becomes a Line period, so you can change the Line period of camera by this setting value of "exposure time". The calculation of the exposure time is different from Sync / Exposure control mode, which is described in the Sync / Exposure control section.

intu: Change the upper byte of exposure time. The valid values are 0-255.

intl: Change the lower byte of exposure time. The valid values are 0-255.

The setting value of exposure time = (intu x 256) + intl

D. Data Rate Control (opck)

opck;

Change Camera Link clock speed and the Camera Link output format (Full/Medium/Base). The number and variation of active modes depends on the camera model. See each model's active modes in the following list.

	Camera Link Configure	Maximum Line rate	Data rate	Camera Link Configure	Maximum Line rate	Data rate	Camera Link Configure	Maximum Line rate	Data rate	Camera Link Configure	Maximum Line rate	Data rate
0	Full Format1	39kHz	85MHz x 8tap	Full Format1	75kHz	85MHz x 8tap	Medium	75kHz	85MHz x 4tap	Base	75kHz	85MHz x 2tap
1	Full Format1	24kHz	50MHz x 8tap	Full Format1	47kHz	50MHz x 8tap	Medium	47kHz	50MHz x 4tap	Base	47kHz	50MHz x 2tap
2	Medium	20.5kHz	85MHz x 4tap	Medium	40.5kHz	85MHz x 4tap	Base	40.5kHz	85MHz x 2tap	-	-	-
3	Medium	12kHz	50MHz x 4tap	Medium	24kHz	50MHz x 4tap	Base	24kHz	50MHz x 2tap	-	-	-
4	Base	10.3kHz	85MHz x 2tap	Base	20.5kHz	85MHz x 2tap	-	-	-	-	-	-
5	Base	6kHz	50MHz x 2tap	Base	12kHz	50MHz x 2tap	-	-	-	-	-	-
6	-	-	-	-	-	-	-	-	-	-	-	-
7	-	-	-	-	-	-	-	-	-	-	-	-
8	Full Format1	38.4kHz	80MHz x 8tap	Full Format1	75kHz	80MHz x 8tap	Medium	75kHz	80MHz x 4tap	Base	75kHz	80MHz x 2tap
9	Medium	19kHz	80MHz x 4tap	Medium	38.5kHz	80MHz x 4tap	Base	38.5kHz	80MHz x 2tap	-	-	-
10	Base	9.5kHz	80MHz x 2tap	Base	19kHz	80MHz x 2tap	-	-	-	-	-	-
11	Full Format1 (*1)	40kHz	85MHz x 8tap	Full Format1 (*1)	80kHz	85MHz x 8tap	Medium (*1)	80kHz	85MHz x 4tap	Base (*1)	80kHz	85MHz x 2tap
23	Full Format2	39kHz	85MHzx8TAP	Full Format2	75kHz	85MHzx8TAP	-	-	-	-	-	-
24	Full Format2	38.5kHz	80MHzx8TAP	Full Format2	75kHz	80MHzx8TAP	-	-	-	-	-	-
25	Full Format2	24kHz	50MHzx8TAP	Full Format2	47kHz	50MHzx8TAP	-	-	-	-	-	-
26	AOI mode (Base)	40kHz	85MHzx2TAP	AOI mode (Base)	75kHz	85MHzx2TAP	AOI mode (Base)	75kHz	85MHzx2TAP	AOI mode (Base)	75kHz	85MHzx2TAP
27	AOI mode (Base)	38.5kHz	80MHzx2TAP	AOI mode (Base)	75kHz	80MHzx2TAP	AOI mode (Base)	75kHz	80MHzx2TAP	AOI mode (Base)	75kHz	80MHzx2TAP
28	AOI mode (Base)	24kHz	50MHzx2TAP	AOI mode (Base)	47kHz	50MHzx2TAP	AOI mode (Base)	47kHz	50MHzx2TAP	AOI mode (Base)	47kHz	50MHzx2TAP

*1...The output width of the CMOS sensor is 9 bit when opck = 11 (denoted by [opck=11]), and it is 10 bit when opck ≠ 11 (denoted by [except 11]). If opck is changed from [11] to [except 11] and vice-versa, the correction value of the FFC will be loaded from EEPROM automatically each time as the behavior of the CMOS sensor is different between [opck=11] and [except 11].

*2...There are several clock speeds and output formats. A user can select clock speed and output format depending on the length of a camera link cable, the speed of a grabber-board, and the total cost.

E. Digital Gain Control (gadt)

gadt;

Set the digital gain.

The possible values are 0-255.

The maximum magnification is four time the gain (in gadt=255).

This is a function of the FPGA.

Digital gain formula is the following.

$$Yw' = (1 + gadt / 64) x (Yw - ffto) + ffto$$

Yw': Level after the digital gain

Yw: Level before the digital gain

ffto: "Offset" target level of FFC

F. Analog Gain Control (gbdt)

gbdt:

This sets the analog gain

On: 4-fold

Off: 1-fold

This is a function of the CMOS sensor. The value will be sent to the corresponding CMOS sensor register.

G. Output bit setting (opbt)

opbt:

This sets the width of the video output.

8: 8 bit

10: 10 bit

H. Check Communication Establishment

cmck:

This checks that the RS232 communication is running.

If you have received the message "OK" the RS232 communication is working.

I. Save / Load / Clear Camera Settings (cmsv / cml d / cmcl)

cmsv: The "CPU RAM" settings stored in the user area of the "CPU EEPROM"

cml d: Load the "CPU EEPROM" settings of the user area into the "CPU RAM"

cmcl: Reset the user area of the "CPU EEPROM". The "CPU RAM" is set to the factory default.

J. To see the "Model", "Firm / FPGA Version" (cmmo / fivr / fpvr)

cmmo: You can see the model number of the camera that is currently connected.

Model number	Product number
37	FS-B2KU7CL
39	FS-B4KU35CL
36	FS-B4KU7CL
35	FS-B8KU35CL
34	FS-B8KU7CL
33	FS-B16KU35CL

fivr: You can see the CPU version of the camera that is currently connected.

fpvr: You can see the FPGA version of the camera that is currently connected.

K. To see active commands (only HyperTerminal) (cmcm)

cmcm;

A list of the active commands will be displayed on the HyperTerminal

Please use only when you communicate with HyperTerminal

Inspection software commands will not be displayed.

L. To see all camera settings (only HyperTerminal) (cmcf)

cmcf:

A list of all the settings will be displayed in HyperTerminal.
Please use only when you communicate with HyperTerminal.
Inspection software commands will not be displayed.

M. Flat Field Correction (FFC)

Shade correction is used for correcting non-uniformity of image brightness resulting from the lens or the imager.

In using this camera, Shade Correction should be used because the imager has fixed pattern noise.

In addition, default setting of the shade correction is ON (ffmd=1)

When we ship this camera, we have shade coefficients in ROM.

The coefficients are automatically loaded at power on.

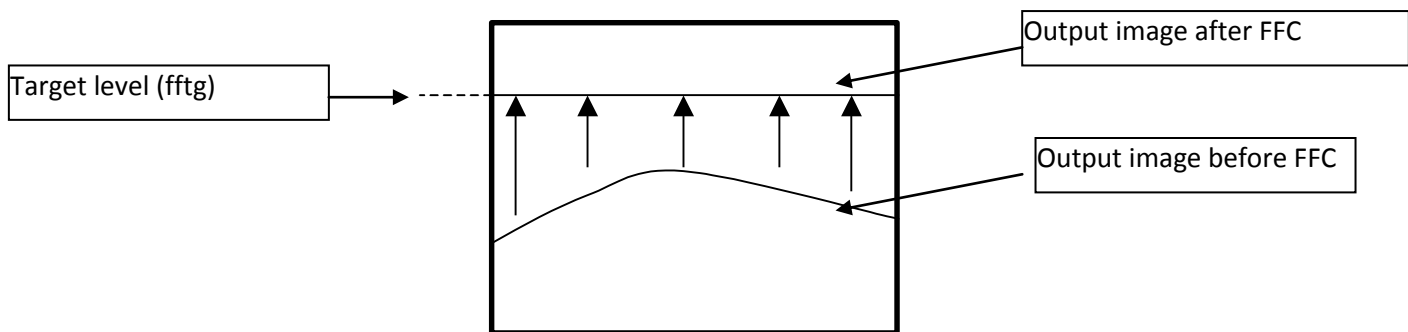

1) Auto Shade Correction Procedure

- ffto=A Set target level to A in a light-shield condition (8 bit)
- ffmd=6 Correct offset level of each pixel in a light-shielding condition in order to make a flat line. (Offset correction value will be calculated only once when *ffmd* is set to 6 from other value).
- fftg=B Set target level to B in a light-receiving condition (8 bit). (The light brightness level must be lower than the target level).
- ffmd=5 Correct offset level of each pixel in a light-receiving condition in order to make a flat line. (Fain correction value will be calculated only once when *ffmd* is set to 5 from other value).
- ffmd=1 Confirm.

2) Manual Shade Correction Procedure (by pixel)

ffgo=Y	Select gain or offset correction value. 1: Gain Correction Value 2: Offset Correction Value
ffdt=C ffdtl=D	Set correction value. value = $D/16 \times 256 + C \times 16$ Note: D should be multiples of 16
ffmd=4 ffds	Set correction mode to "all pixels". Apply
ffmd=1	Confirm

3) Manual Shade Correction Procedures (all pixels)

ffgo=Y	Select gain or offset correction value. 1: Gain Correction Value 2: Offset Correction Value
ffpl=A ffpu=B	Set a pixel address. addr = $B \times 256 + A$
ffdt=C ffdtl=D	Set correction value. value = $D/16 \times 256 + C \times 16$ Note: D should be multiples of 16
ffmd=3 ffds	Set correction mode to "by pixel". Apply
ffmd=1	Confirm

N. Save correction value (FFC)

ffsv:
Save correction value of FFC (Gain and Offset). Transfer the data from the RAM to the EEPROM.
(For more information, please refer to the outline on the camera memories-related FFC).

O. Load Correction Value (FFC)

ffld:
Load correction value of FFC (Gain and Offset). Transfer from EEPROM to RAM.
(For more information, please refer to the Outline on the camera memories-related FFC).

P. Clear FFC RAM (FFC)

If you want to clear the RAM of only offset or of only gain, use these commands.

ffcq: Clear "FFC RAM" of gain.

ffco: Clear "FFC RAM" of offset.

Q. Anti-blooming setting (abmd)

abmd:

Sets Anti-blooming ON/OFF

0: OFF

1: ON

This is a function of the CMOS sensor. You are sending a registry to the CMOS Sensor.

R. User ID (usid)

usid:

When using multiple cameras, you can set the ID for each camera.

The camera ID can be saved by a save command (cmsv) in the user area of the "CPU EEPROM", but cannot be cleared by a clear command.

The possible values are 0-255.

S. Area of Interest (AOI)

AOI is the function that only the specific portion of 1 line is output from the camera.

The start pixel output can be set by using the risu and risl.

Product number	The start pixel outputted	
	AOI mode (Base)	AOI mode (Full)
FS-B2KU7CL	$N = (\text{risu} * 256 + \text{risl}) * 2 + 1$	-
FS-B4KU35CL	$N = (\text{risu} * 256 + \text{risl}) * 4 + 1$	-
FS-B4KU7CL	$N = (\text{risu} * 256 + \text{risl}) * 2 + 1$	-
FS-B8KU35CL	$N = (\text{risu} * 256 + \text{risl}) * 4 + 1$	$N = (\text{risu} * 256 + \text{risl}) * 8 + 1$
FS-B8KU7CL	$N = (\text{risu} * 256 + \text{risl}) * 2 + 1$	$N = (\text{risu} * 256 + \text{risl}) * 8 + 1$
FS-B16KU35CL	$N = (\text{risu} * 256 + \text{risl}) * 2 + 1$	-

The width of LVAL can be set by using the command riwu and riwl

The width of LVAL = (riwu * 256 + riwl) pixels

Please set the width of LVAL shorter than the line rate. If the width of LVAL is longer than the line rate, the image isn't output from the camera.

The output format, which is only base configuration, follows:

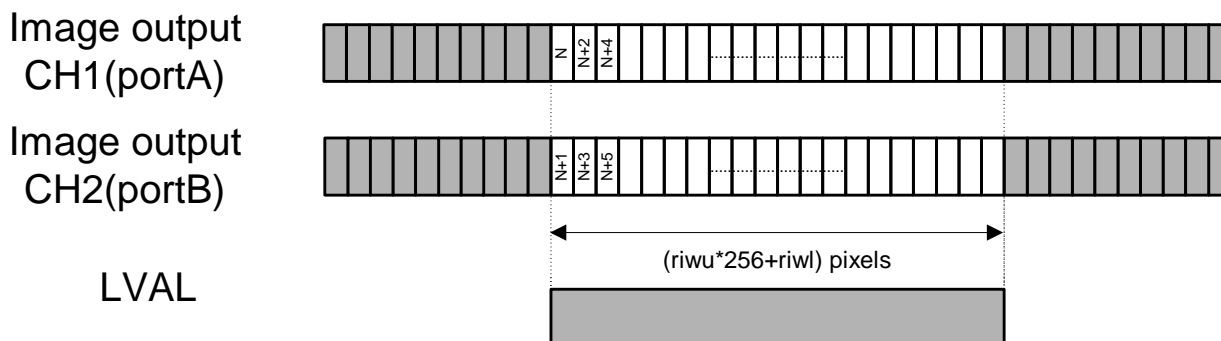

VIII. Others

A. Outline on the camera memories-related CPU

There are several non-volatile (EEPROM) and volatile (RAM) memories loaded in a camera.
Please see the diagram below. This section describes the memory related CPU.

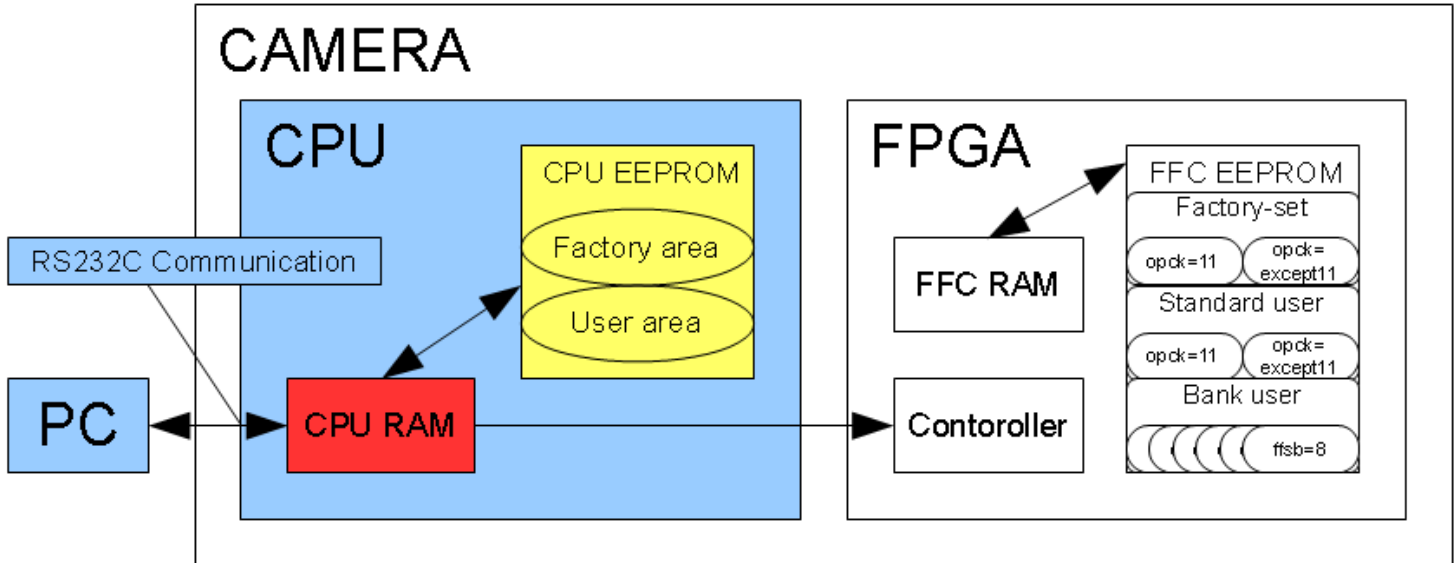

1. CPU RAM

The setting is sent via RS232 communication and is stored in the "CPU RAM". If a user wants to use the setting of "CPU RAM" later, the data must be saved from "CPU RAM" into "CPU EEPROM" before the power is turned off.

2. CPU EEPROM

"CPU EEPROM" is divided into two areas; "User area" and "Factory area"

Factory area:

Factory setting data is stored here. This is read only and cannot be accessed directly.

User area:

User setting data is stored here. This can be accessed with the commands cmsv / cml.

3. To set factory settings

If a user wants to set the "CPU RAM" settings to the factory default, please send the Clear command (cmcl).

The user area of the "CPU EEPROM" is reset when the Clear command (cmcl) is sent, factory setting will then be loaded into "CPU RAM".

4. Behavior of Power

When the power is turned on, Factory settings are loaded into the "CPU RAM" first. User settings will be loaded afterwards.

Therefore, if nothing is saved in the user settings, "CPU RAM" is set to the factory default.

B. Outline on the camera memories-related FFC

There are several non-volatile (EEPROM) and volatile (RAM) memories loaded in a camera. See the block diagram below. This section describes the memory related FFC.

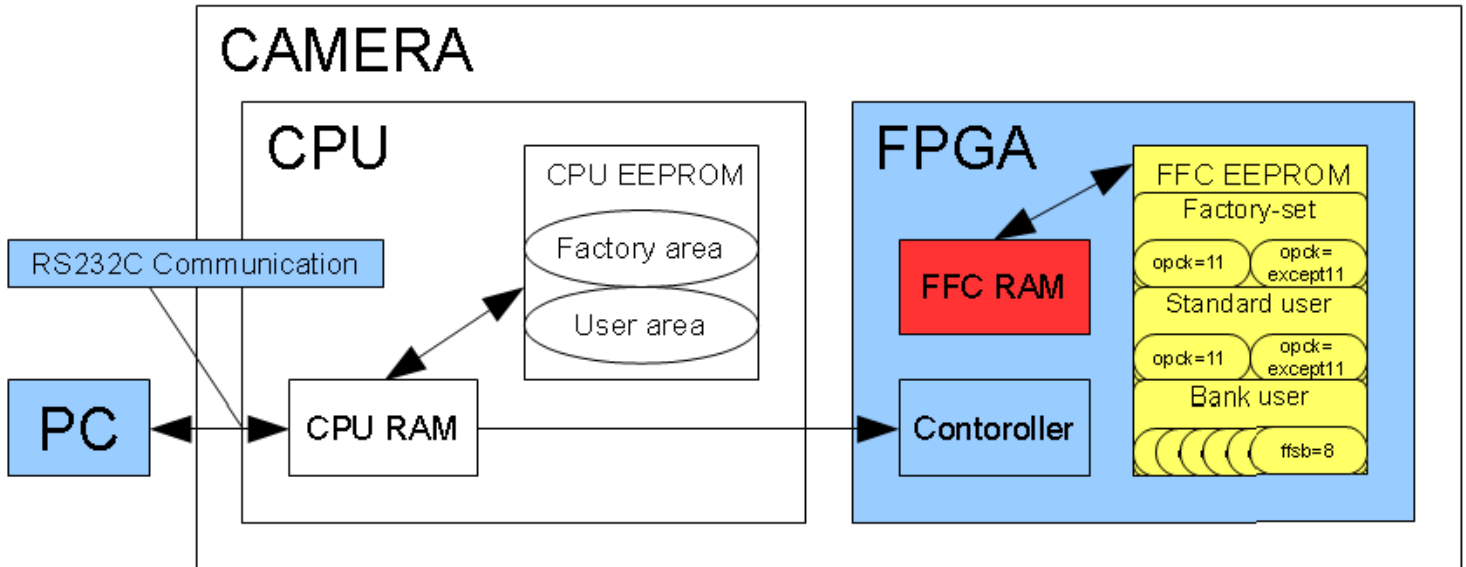

1. FFC RAM

“FFC RAM” is for storing a correction data of the Offset and Gain of FFC. When you transfer data between “FFC RAM” and “FFC EEPROM”, data of Gain and Offset is 1 set. FFC will be corrected with the data of “FFC RAM”. If a user wants to use the data of “FFC RAM” later, please save the data of “FFC RAM” into “FFC EEPROM” before the power is turned off.

2. FFC EEPROM

“FFC EEPROM” is divided into three separate areas; “Standard user”, “Bank user”, and “Factory-set”.

Factory Set

Factory setting data is stored here. This is a read only area. Factory-set is accessible with the command fflf. The area “Factory-set” is divided into two areas: opck=11 and opck=(all except 11) as the behavior of the CMOS sensor is different between opck=11 and opck=all except 11. When you send “FFC EEPROM” the access command (fflf), the accessing area will change depending on the state of the opck automatically.

Standard User

This area is for a single bank user. When ffum=0, then Standard User should be accessed. Standard User is accessible with the commands ffsv / ffld. The area “Standard user” is divided into two areas; opck=11 and opck=(all except 11), as the behavior of the CMOS sensor is different between opck=11 and opck=all except 11. When the “FFC EEPROM” is sent an access command (ffsv / ffld), the accessing area will change depending on the opck.

Bank user

You can store several patterns of correction data. When ffum=1, then Bank user should be accessed. Bank user is accessed with the commands (ffsv / ffld). The Bank user area is divided into eight areas. The area is switched by the command ffsb. Note that the areas cannot be switched depending on opck.

3. Behavior of Power

When the power is turned on, the “FFC EEPROM” will be loaded into “FFC RAM” from a predetermined area of the “FFC EEPROM” by the state of ffum / ffsb / opck.

IX. Test Patterns

A. FS-B2KU7CL-C, FS-B2KU7CL-F

Test Pattern 1 (tsmd=1)



Test Pattern 2 (tsmd=2)



Test Pattern 3 (tsmd=3)



Test Pattern 4 (tsmd=4)



B. FS-B4KU7CL-C / FS-B4KU7CL-F, FS-B4KU35CL-C / FS-B4KU35CL-F

Test Pattern 1 (tsmd=1)

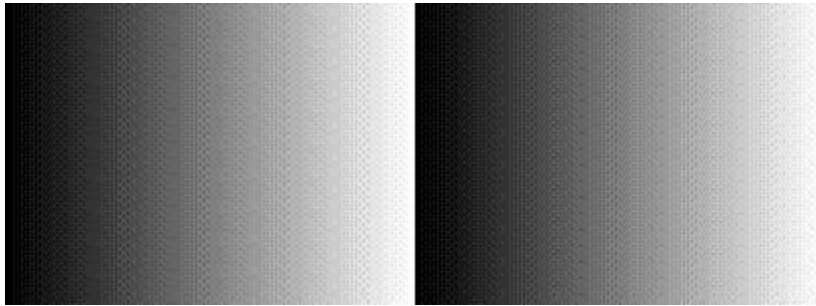

Test Pattern 2 (tsmd=2)

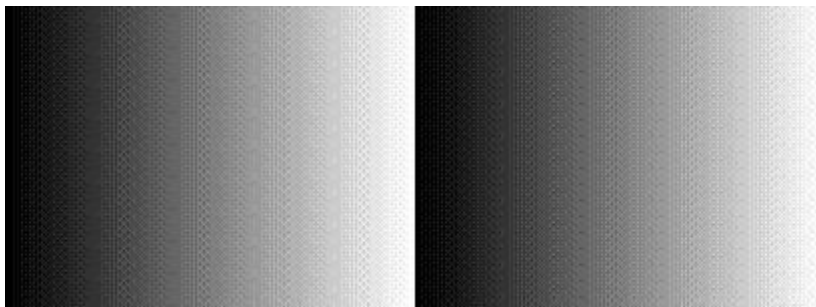

Test Pattern 3 (tsmd=3)

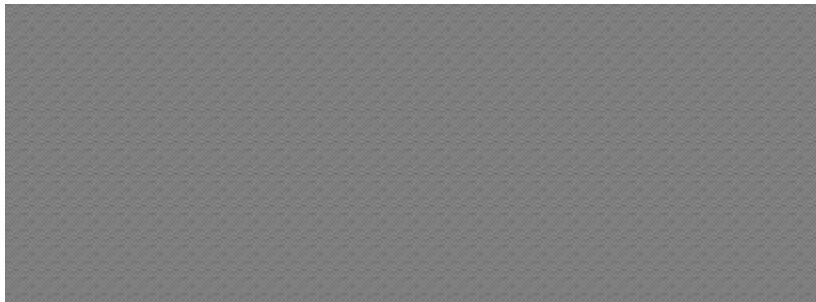

Test Pattern 4 (tsmd=4)

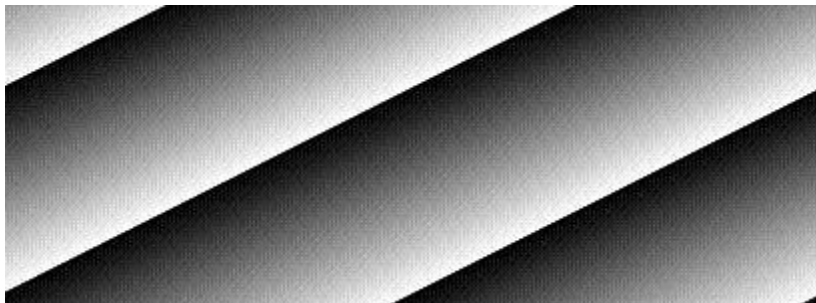

C. FS-B8KU35CL-F, FS-B8KU7CL-M72

Test Pattern 1 (tsmd=1)



Test Pattern 2 (tsmd=2)



Test Pattern 3 (tsmd=3)



Test Pattern 4 (tsmd=4)



D. FS-B16KU35CL-M72

Test Pattern 1 (tsmd=1)



Test Pattern 2 (tsmd=2)



Test Pattern 3 (tsmd=3)



Test Pattern 4 (tsmd=4)



X. Quantum Efficiency

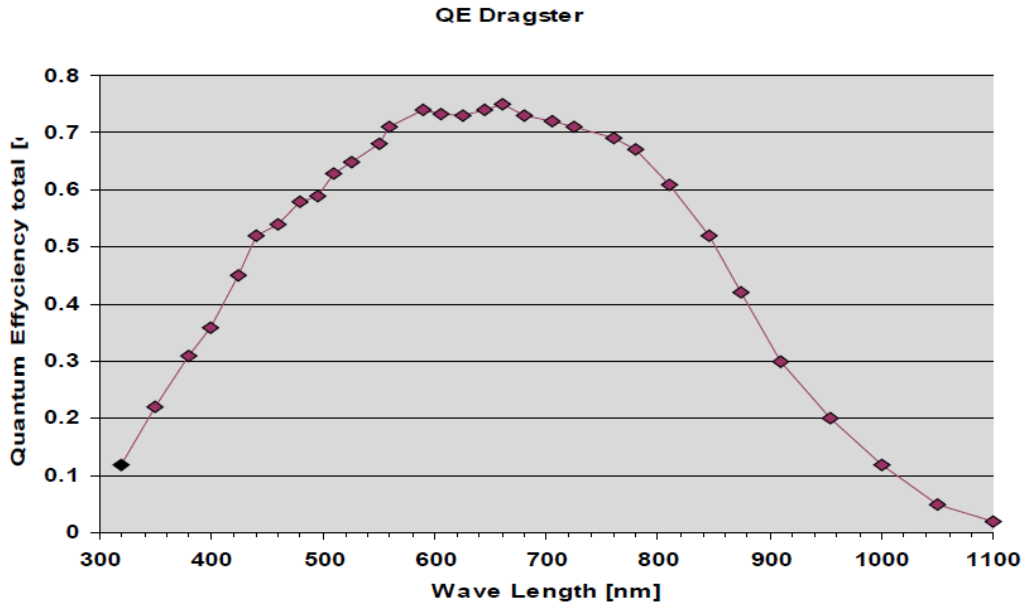

XI. Dimension

A. FS-B2KU7CL-C

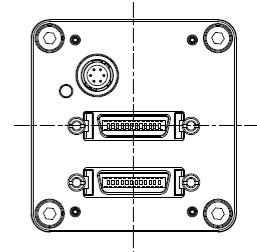
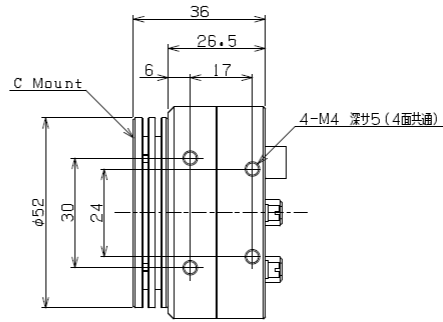
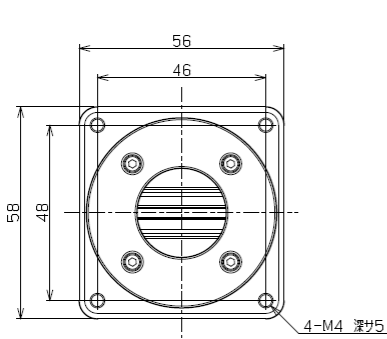
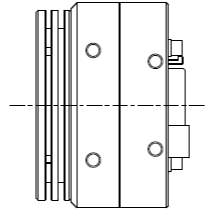
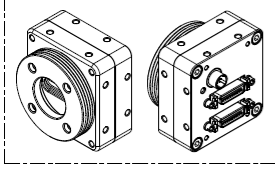

Unit: mm

B. FS-B8KU35CL-F, FS-B4KU7CL-F, FS-B4KU35CL-F, FS-B2KU7CL-F

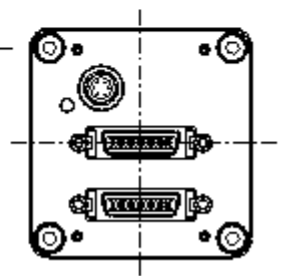
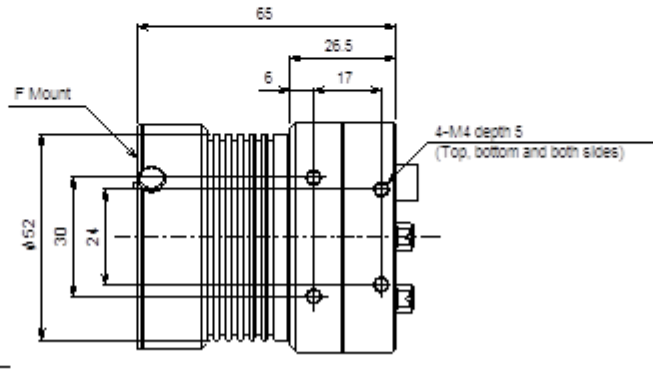
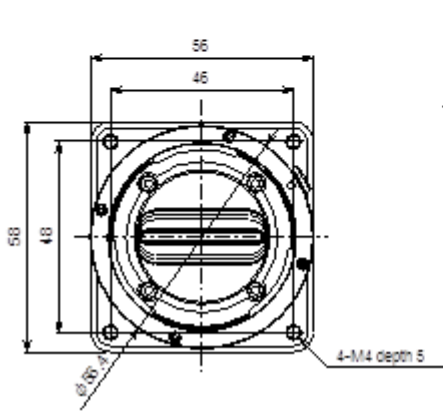
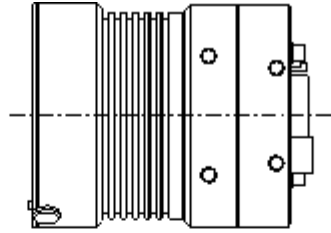
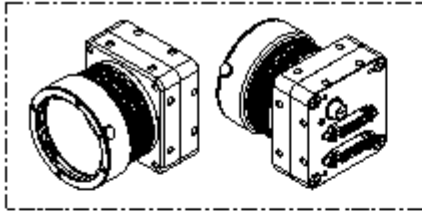

Unit: mm

C. FS-B16KU35CL-M72, FS-B8KU7CL-M72

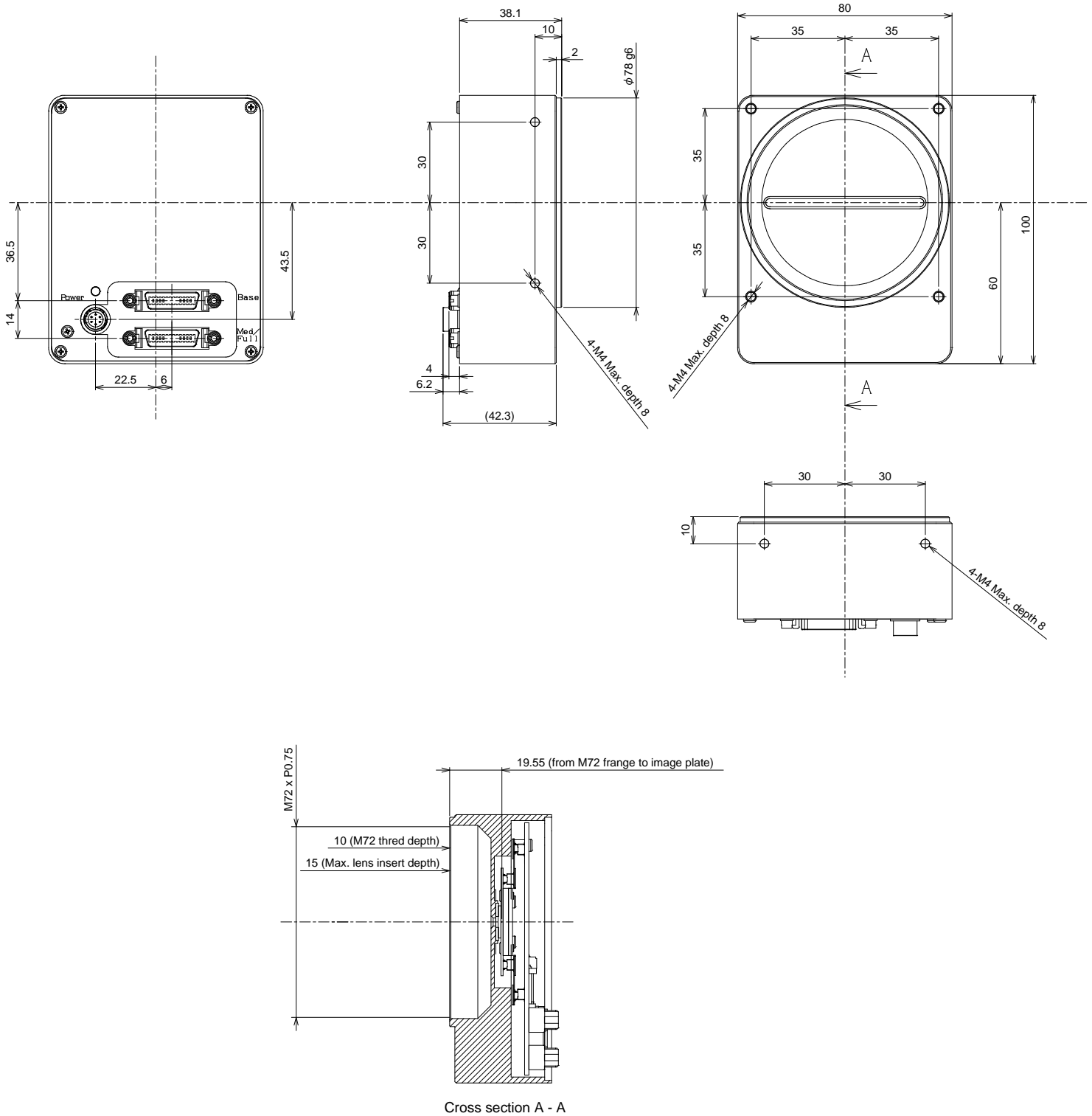

Revisions

Rev	Date	Change	Notes
1.03	May 24, 2012	New Doc	
1.04	June 19, 2012	Added AOI Updated Maximum Line Rate for 16k	
1.09	April 10, 2013	Update	
1.11	September 5, 2013	Updated (Accuracy)	

Senor Technologies America, Inc.

1345 Valwood Parkway, Suite 320
Carrollton, Texas 75006-6891
TEL (972)481-9223 FAX(972) 481-9209
URL <http://www.sentechamerica.com/>

Sensor Technology Co., Ltd.

7F, Harada Center Building
9-17, Naka cho 4 chome
Atsugi-city, Kanagawa
243-0018 Japan
TEL +81-46-295-7061 FAX +81-46-295-7066
URL <http://www.sentech.co.jp/>

Taiwan Sensor Technology, Inc.

3F-6, No. 9, Aiguo W, Rd., Jhong Jheng
District Taipei City 100, Taiwan, R.O.C.
TEL 886-2-2383-2331
FAX 886-2-2370-8775
EMAIL sentech0501@yahoo.com.tw