

Product Specification Sheet

General Description

The Power Brick AC ARM is a smart servo drive package. It combines the intelligence and capability of the Power PMAC motion controller with high performance IGBT-based amplifier resulting into a 4, or 8-axis compact smart drive. It is designed for up to 240 VAC main input power and supports virtually any type of feedback device.

The number of axes in a Power Brick AC ARM application can be expanded through MACRO or EtherCAT. Additionally, this drive carries up to 32 digital inputs and 16 digital outputs (I/Os) which can also be expanded through MACRO, ModBus, or EtherCAT.

Part Number Designation

PRODUCT: Power Brick AC ARM

B
D
E
G
H
I
J
K
L
M
N
O

P	B	A		-	A			0			-							0
---	---	---	--	---	---	--	--	---	--	--	---	--	--	--	--	--	--	---

Option B	
4:	4-Axis
8:	8-Axis

Option D	
A:	1GB RAM, 4GB Flash
E:	2 GB RAM, 4GB Flash

Option GH			
	Axis 1-4	Axis 5-8	No. Enc.
50:	5/10A	-	4
5A:	5/10A	-	8
80:	8/16A	-	4
8A:	8/16A	-	8
55:	5/10A	5/10A	8
85:	8/16A	5/10A	8
88:	8/16A	8/16A	8

Option E	
0:	No EtherCAT®
1:	I/O only
2:	I/O + 4 Servo Axis
3:	I/O + 8 Servo Axis
5:	I/O + 16 Servo Axis
9:	I/O + 32 Servo Axis

Option I	
0:	-
1:	MACRO

B**D E****G H****I J K L M N O**

P	B	A		-	A			0			-							0
----------	----------	----------	--	---	----------	--	--	----------	--	--	---	--	--	--	--	--	--	----------

Option J	
0:	16/8 Digital I/O
1:	32/16 Digital I/O ^{*1}
A:	PROFIBUS-DP Master
B:	PROFIBUS-DP Slave
C:	DeviceNet Master
E:	DeviceNet Slave
F:	CANopen Master
G:	CANopen Slave
H:	CC-Link Slave
J:	EtherCAT Slave
K:	Ethernet/IP Scanner
L:	Ethernet/IP Adapter
M:	Open Modbus / TCP
N:	PROFINET IO RT Controller
P:	PROFINET IO RT Device

Option O				
	True DAC	Filtered PWM	Analog Inputs	GP Relays
0:	-	-	-	-
1:	-	4	8	4
2: ^{*1}	-	8	4	8
4: ^{*1}	4	-	4	4
5: ^{*1}	4	4	4	8

Option K	
	Axis 1-4
0:	-
A:	ACI ^{*2}
R:	Resolver
S:	Sinusoidal

Option M ^{*4}	
	Axis 1-4
0:	-
2:	SSI
3:	EnDat
4:	HiperFace
6:	Yaskawa III/V
7:	Tamagawa
8:	Panasonic
9:	Mitutoyo
B:	BiSS B/C
C:	Matsushita
D:	Mitsubishi
E:	Omron 1S
F:	TBPC ^{*3}
G:	XY2-100

Option L ^{*1}	
	Axis 5-8
0:	-
A:	ACI ^{*2}
R:	Resolver
S:	Sinusoidal

Option N ^{*1*4}	
	Axis 5-8
0:	-
2:	SSI
3:	EnDat
4:	HiperFace
6:	Yaskawa III/V
7:	Tamagawa
8:	Panasonic
9:	Mitutoyo
B:	BiSS B/C
C:	Matsushita
D:	Mitsubishi
E:	Omron 1S
F:	TBPC ^{*3}
G:	XY2-100

*1. Only available with 8 encoders option in GH

*2. ACI: Auto-Correcting Interpolator

*3. TBPC: Table-Based Position Compare

*4. ACC-84B Options

Specifications

1. Classification	
1.1 Name	Power Brick AC ARM
1.2 Type	Programmable Servo Amplifier
2. Construction	
2.1 Dimensions	Refer to the dimensions in the drawings below.
2.2 Enclosure	<ul style="list-style-type: none"> • Mounted with a traditional 3-hole panel mount • Airflow must not be obstructed • Install in an area that is protected from direct sunlight, corrosives, harmful gases or liquids, dust, metallic particles, and other contaminants.
3. Mechanical	
3.1 Weight	<ul style="list-style-type: none"> • 4-axis ~13lbs • 8-axis ~18lbs
4. Ratings	
4.1 Output Current (Per Axis)	Continuous Current: 5 A _{rms} , 8 A _{rms} (based on configuration)
	Peak Current: 10 A _{rms} , 16 A _{rms} (based on configuration)
	Time at Peak Current: 2 seconds
4.2 Logic Power Supply Input	24 VDC ± 5%
4.3 Logic Power Supply Current	5 A _{rms}
4.4 Main AC Input Line Voltage	90 – 250 VAC _{rms}
4.5 Output Power (Modulation depth of 60% RMS)	PBA4-Axx-55: 1000W (per axis) PBA8-Axx-88: 1400W (per axis) PBA4-Axx-88: 1400W (per axis) PBA8-Axx-85: 1200W (axis 5-8) PBA8-Axx-55: 1000W (per axis)
4.6 Over Voltage	~ 307 VAC / 435 VDC (±2 %)
4.7 Under Voltage	~ 70 VAC / 100 VDC (±5 %)
5. Environmental Test	
5.1 Ambient Temperature	0 °C (32 °F) to 45 °C (113 °F)
5.2 Humidity	10% to 95% at up to 35°C (95°F) with no condensation and icing
	10% to 85% from 35°C to 50°C (122°F) with no condensation and icing
5.3 Air Flow Clearances	3" (76.2 mm) above and below unit for air flow
5.4 Cooling	Natural convection and external fan
5.5 Environment ISA 71-04	Degree 2 environments
6. Environmental Storage	
6.1 Ambient Temperature	-25 °C (-13 °F) to 70 °C (158 °F) with no condensation and icing
6.2 Atmosphere	Must be free from corrosive gases.
7. Environmental Operation	
7.1 Ambient Operating Temperature	0 °C (32 °F) to 45 °C (113 °F)
7.2 Ambient Operating Humidity	5% to 95% at up to 35°C (95°F) with no condensation and icing
	5% to 85% from 35°C up to 50°C (122°F)with no condensation and icing
7.3 Atmosphere	Must be free from corrosive gases.
7.4 Atmospheric Pressure	70 kPa to 106 kPa
8. General Precautions	
8.1 Safety Precautions	Please refer to the Power Brick AC ARM User Manual (MN-000142).

Performance

1. Standard	
1.1 CPU	1.0 GHz Dual-Core ARM
1.2 Memory	1 GB DDRAM3, 1 GB Flash
1.3 Communications Ports	<ul style="list-style-type: none"> • 2 x Gbs Ethernet port for host communication • USB 2.0 Host port • USB 2.0 Device port
1.4 Digital I/O	<ul style="list-style-type: none"> • 16 x Inputs, fully protected at 12 – 24 V sourcing or sinking • 8 x Outputs, fully protected at 12 – 24 V sourcing or sinking
1.5 Limits, Flags, and EQU	Per channel: <ul style="list-style-type: none"> • 2 limit inputs (Plus and Minus) • 2 flag inputs (Home and User) • 1 EQU output
1.6 Servo Interface	Four channels servo interface, each including list below: <ul style="list-style-type: none"> • Quadrature encoder (differential, with index) interface • UVW digital hall sensor interface • Serial encoder interface (software configurable): <ul style="list-style-type: none"> ◦ SSI ◦ EnDat 2.1 / 2.2 (2.1-compatible features only) with delay comp. ◦ Hiperface ◦ Yaskawa Sigma I / II / III / V (no position reset or fault clear) ◦ Tamagawa FA-Coder (no servo clock output) ◦ Panasonic (no servo clock output) ◦ Mitutoyo ◦ Kawasaki • Pulse & direction output. • Position compare (EQU) output (5 V TTL) • Input flags (home, + limit, – limit, user) at 5 – 24 V • Motor thermal input (PTC)
1.7 Amplifier Output	4 amplifier axes, each at 5/10A
1.8 Amplifier Safety & Features	<ul style="list-style-type: none"> • Internal shunt / bleeding resistor built-in. • External shunt connection. • Shunt resistor fault detection. • Hardware I2T thermal fault detection. • Short circuit detection. • IGBT over-temperature detection. • PWM frequency out-of-range detection. • No bus voltage detection. • Soft start fault detection. • Watchdog output (normally closed / open). • Abort Input (category 2 stop). • STO Input (category 0 stop).
2. Optional	
2.1 Memory	2 GB DDRAM3, 4 GB Flash
2.2 Digital I/O	<ul style="list-style-type: none"> • Additional 16 x Inputs, fully protected at 12 – 24 V sourcing or sinking • Additional 8 x Outputs, fully protected at 12 – 24 V sourcing or sinking
2.3 Analog I/O	<ul style="list-style-type: none"> • 4 or 8 x 16-bit analog inputs • 4 or 8 x 14-bit filtered PWM analog outputs (± 10 V) • 4 x 16-bit true DAC analog outputs (± 10 V) • 4 or 8 x Amp enable outputs (to 3rd party drives) • 4 or 8 x Amp fault inputs (from 3rd party drives)

2.4 Servo Interface	<p>Four additional servo channels with options listed below:</p> <ul style="list-style-type: none"> • Sinusoidal encoder interface (x16384). • Auto-Correcting Interpolator ACI sinusoidal encoder interface (x65536) • Resolver encoder interface. • ACC-84B protocols: <ul style="list-style-type: none"> ◦ BiSS-B/C ◦ Omron1S ◦ Galvanometer XY2-100 ◦ EnDat 2.2 with additional information, no delay compensation ◦ Hiperface (no additional capability over Gate3 built-in interface) ◦ Yaskawa Sigma II/III/V with position reset and fault clear ◦ Tamagawa FA-Coder with servo clock output ◦ Mitsubishi ◦ Matsushita (Nikon D) ◦ SSI (no additional capability over Gate3 built-in interface) ◦ Panasonic (no additional capability over Gate3 built-in interface) ◦ Mitutoyo (no additional capability over Gate3 built-in interface) ◦ Table Based Position Compare Provided by ACC-84B 		
2.5 Amplifier Output	4 additional amplifier axes, each at 5/10 A or 8/16 A		
2.6 Ethernet/IP	<p>Implicit I/O Message Service:</p> <ul style="list-style-type: none"> • Number of connection types: 32 • Packet interval (refresh cycle): 1 to 1,000 ms in 0.5-ms increments • Maximum link data size per node: 16,128 byte • Maximum data size per connection: 504 byte <p>Explicit I/O Message Service:</p> <ul style="list-style-type: none"> • Number of servers that can communicate at one time: 32 max. 		
2.7 MACRO Interface	<ul style="list-style-type: none"> • 16 Servo, 12 I/O nodes interface • 32 Servo, 24 I/O nodes interface 		
2.8 EtherCAT Interface (Firmware Option)	<ul style="list-style-type: none"> • EtherCAT I/O only • 4 / 8 / 16 / 32 Servo axes plus I/O 		
2.9 Fieldbus (ACC-72 Option)	<table border="0" style="width: 100%;"> <tr> <td style="vertical-align: top;"> <ul style="list-style-type: none"> • EtherNet / IP Scanner / Master • EtherNet / IP Adapter / Slave • Open Modbus / TCP • PROFINET IO RT Controller • PROFINET IO RT Device • CANopen Master • CANopen Slave </td> <td style="vertical-align: top; padding-left: 20px;"> <ul style="list-style-type: none"> • PROFIBUS-DP Master • PROFIBUS-DP Slave • DeviceNet Master • DeviceNet Slave • CC-Link Slave • EtherCAT Slave • Modbus </td> </tr> </table>	<ul style="list-style-type: none"> • EtherNet / IP Scanner / Master • EtherNet / IP Adapter / Slave • Open Modbus / TCP • PROFINET IO RT Controller • PROFINET IO RT Device • CANopen Master • CANopen Slave 	<ul style="list-style-type: none"> • PROFIBUS-DP Master • PROFIBUS-DP Slave • DeviceNet Master • DeviceNet Slave • CC-Link Slave • EtherCAT Slave • Modbus
<ul style="list-style-type: none"> • EtherNet / IP Scanner / Master • EtherNet / IP Adapter / Slave • Open Modbus / TCP • PROFINET IO RT Controller • PROFINET IO RT Device • CANopen Master • CANopen Slave 	<ul style="list-style-type: none"> • PROFIBUS-DP Master • PROFIBUS-DP Slave • DeviceNet Master • DeviceNet Slave • CC-Link Slave • EtherCAT Slave • Modbus 		

4-Axis Power Brick AC ARM Dimensions

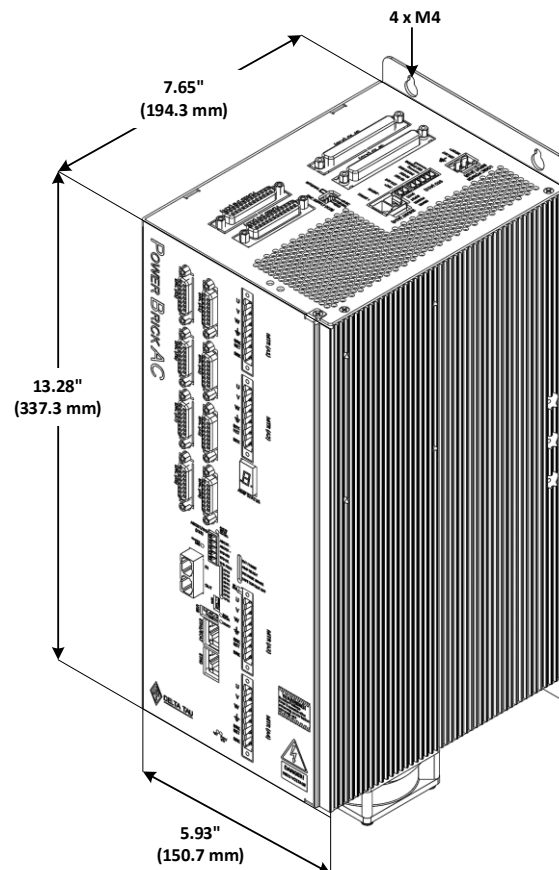
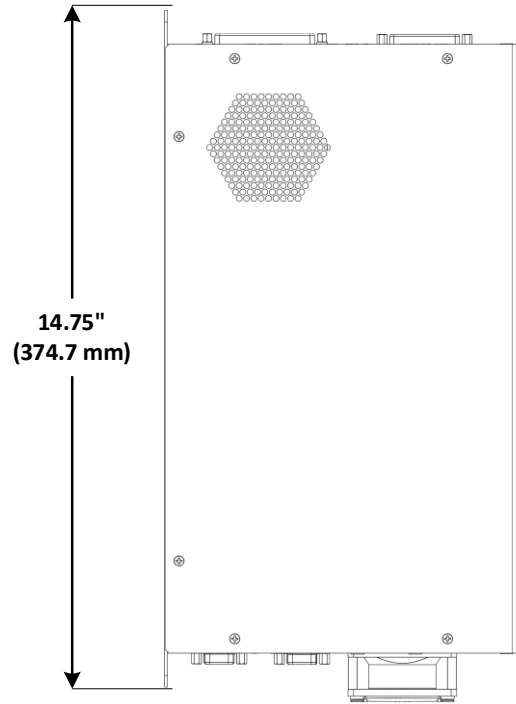
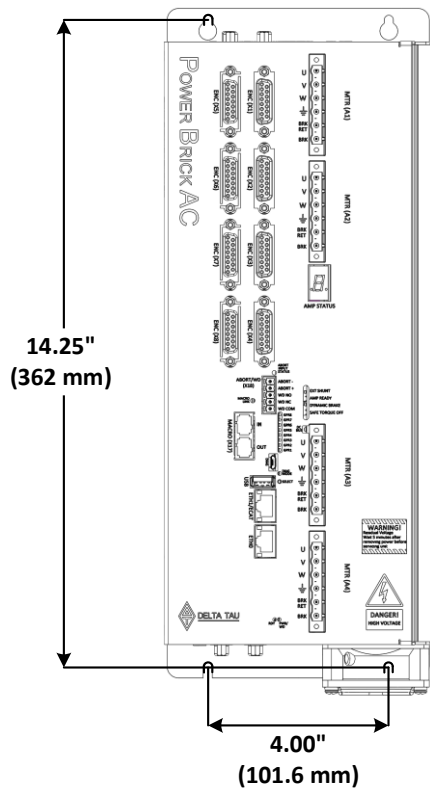

8-Axis Power Brick AC ARM Dimensions

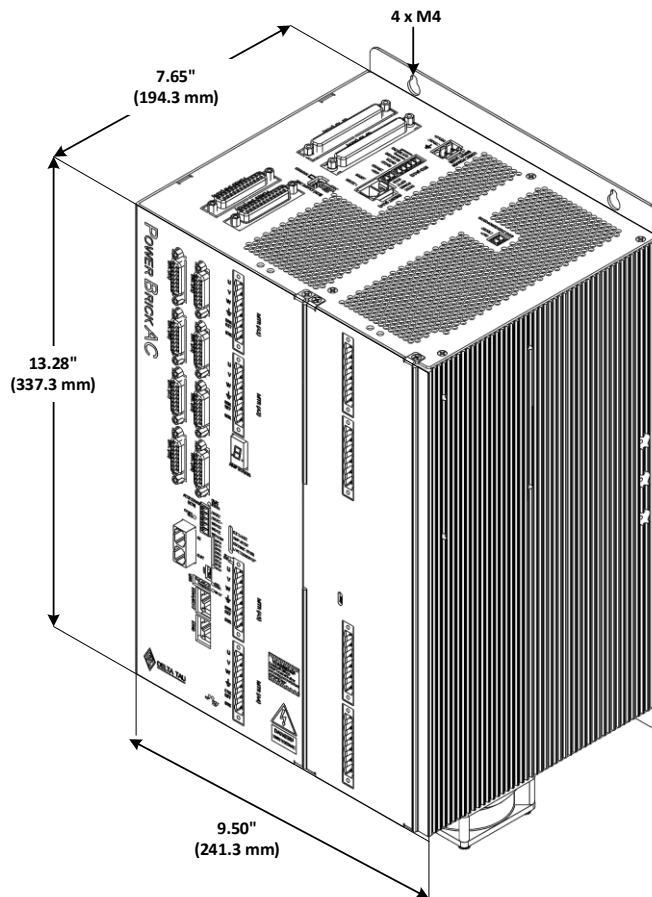
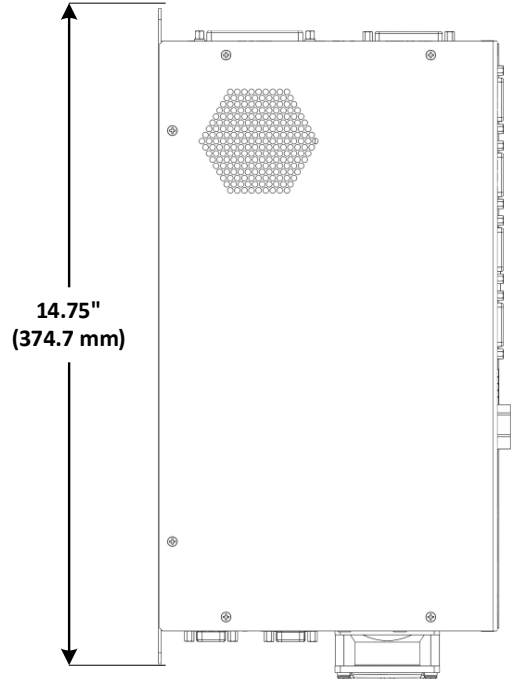
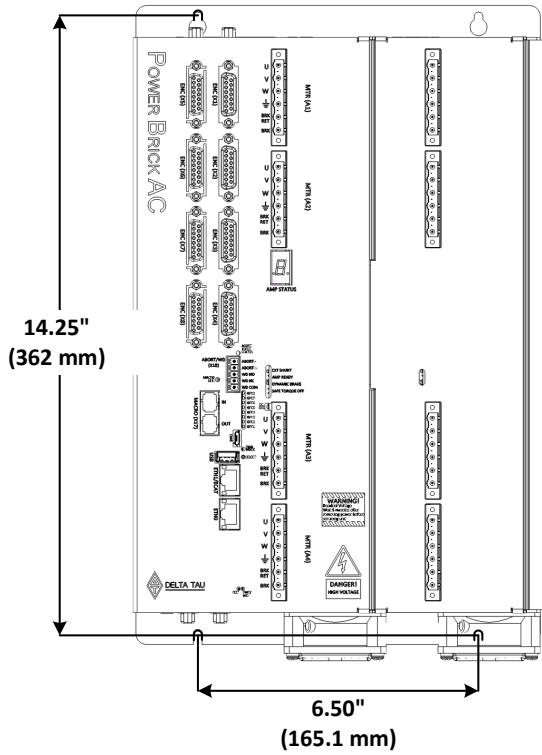

Power Brick AC ARM Connector Locations

Front View

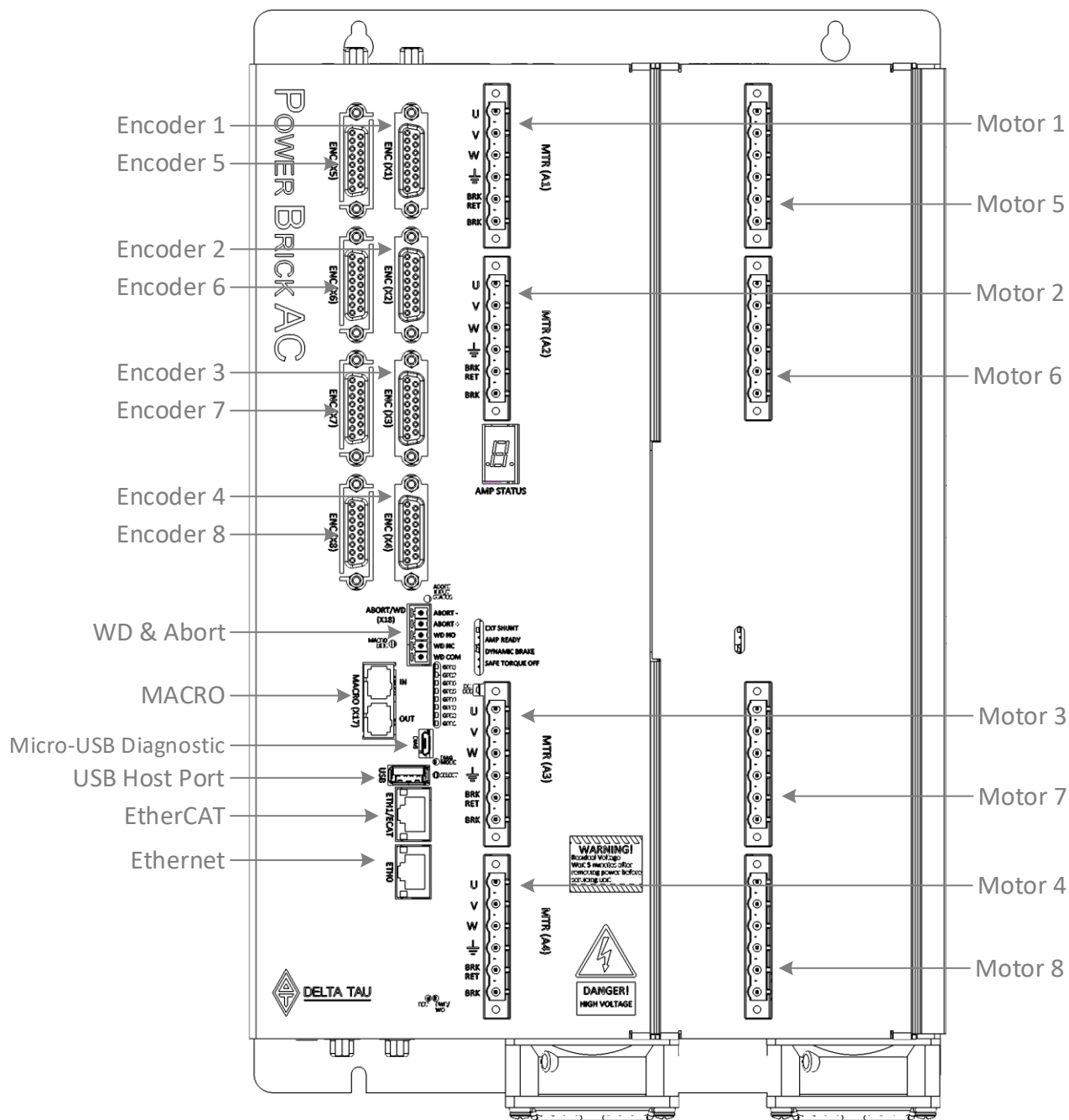

Top View

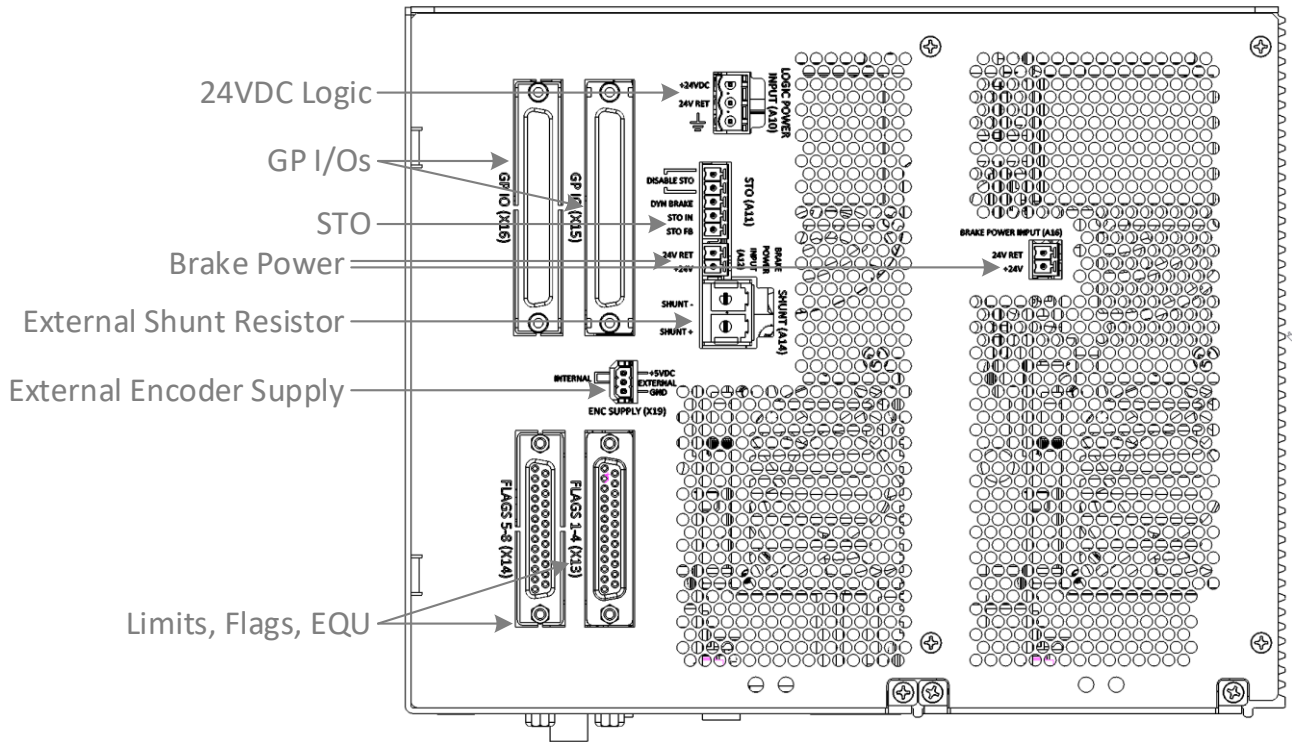

Bottom View

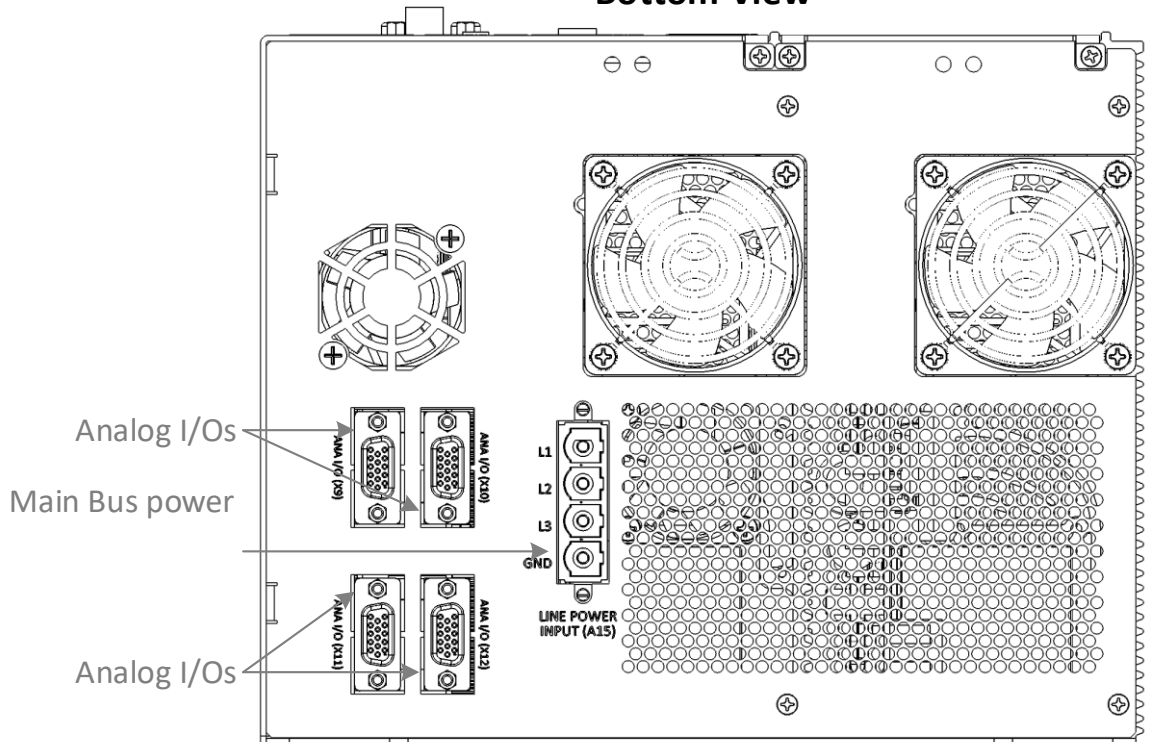

21314 Lassen Street
Chatsworth, CA 91311

This specification sheet is provided to the customers of Delta Tau Data Systems, Inc. as a reference.

REVISION HISTORY				
Rev	Date	Prepared by	Reviewed by	Approved by
A	November 1, 2020	SM	RN	RN
B	April 16, 2021	SM	RN	RN

Terms and Conditions Agreement

Please observe that Delta Tau Data Systems, Inc. set the Terms and Conditions for use, storage, disposal and so on (including precautionary statements and warning and so on described in instruction manuals, catalogs and specifications of the products).

The Terms and Conditions hereunder are applied to the products regardless of where they are purchased, unless otherwise is specifically agreed. However, if there is any inconsistency between the Terms and Conditions and the items described in this product specification, the items described in this product specification are taken precedence.

1. Definition

The definitions used in these Terms and Conditions are as follows:

- (1) *Catalogues*: Delta Tau general catalogue "BEST", electronic/mechanism components general catalogue and other catalogues, specifications, instructions and manuals of the products, including electronically provided information available on the *Omron* website, etc.
- (2) *Usage conditions*: Usage conditions, rating, performance, operating environment, handling instructions, cautions, prohibited use, etc. of the products described in specifications, documentations or manuals.
- (3) *Customer application*: Application of the products by customers which include embedding and/or using the products in their parts/components, electronic substrates, devices, equipment or systems manufactured by customers.
- (4) *Fitness*: *Customer application* for the products (a)Fitness, (b)performance, (c) non-infringement of third-party intellectual property, (d) compliance with laws and regulations and (e)conformity to various standards.

2. Notes on Catalogues

Attention is required to the following points for information obtained from *Catalogues*.

- (1) Rated values and performance values are the product of tests performed for separate single conditions, including but not limited to temperature and humidity. *Delta Tau* does not warrant rated values and performance values for multiple combined conditions.
- (2) Reference data are provided for reference only. *Delta Tau* does NOT warrant that the products work properly at all times in the range of reference data.
- (3) Application examples are provided for reference only. *Delta Tau* does NOT warrant the *Fitness* of the products under such applications.
- (4) *Delta Tau* may discontinue the production of the products or change the specifications of them for the purpose of improving such products or other reasons entirely at its own discretion.

3. Precautions

Please be aware of and accept the following when you introduce or use the products:

- (1) Please use the products in compliance with *usage conditions* including rating and performance limits.
- (2) Please confirm the *fitness* of the products in your application and use your own judgment to determine the appropriateness of using them in such application. *Delta Tau* shall not warrant the *fitness* of the products in *customer applications*.
- (3) Please confirm that the products are properly wired and installed for their intended use in your overall system.
- (4) When using the products, please make sure to (i) maintain a margin of safety between the published rated and performance values, and the application requirements, (ii) design to minimize risks to *customer application* in case of failure of the products, such as introducing redundancy, (iii) introduce system-wide safety measures to notify risks to users, and (iv) conduct regular maintenance on the products and *customer application*.
- (5) *Delta Tau* shall not be responsible and/or liable for any loss, damage, or expenses directly or indirectly resulting from the infection of the products, any software installed thereon or any computer equipment, computer programs, networks, databases or other proprietary material connected thereto by distributed denial of service attack, computer viruses, other technologically harmful material and/or unauthorized access.

It shall be the users sole responsibility to determine and use adequate measures and checkpoints to satisfy the users particular requirements for (i) antivirus protection, (ii) data input and output, (iii) maintaining a means for reconstruction of lost data, (iv) preventing the Products and/or software installed thereon from being infected with computer viruses and (v) protecting the Products from unauthorized access.

(6) The products are designed and manufactured as general-purpose products for use in general industrial applications. They are not intended to be used in the following critical applications. If you are using the products in the following applications, *Delta Tau* shall not provide any warranty for such the products, unless otherwise specifically agreed or unless the specific applications are intended by *Delta Tau*.

(a) Applications with stringent safety requirements, including but not limited to nuclear power control equipment, combustion equipment, aerospace equipment, railway equipment, elevator/lift equipment, amusement park equipment, medical equipment, safety devices and other applications that could cause danger/harm to people's body and life.

(b) Applications that require high reliability, including but not limited to supply systems for gas, water and electricity, etc., 24 hour continuous operating systems, financial settlement systems and other applications that handle rights and property.

(c) Applications under severe condition or in severe environment, including but not limited to outdoor equipment, equipment exposed to chemical contamination, equipment exposed to electromagnetic interference and equipment exposed to vibration and shocks

(d) Applications under conditions and environment not described in *Catalogues*

(7) In addition to the applications listed from (a) to (d) above, the products are not intended for use in vehicles designed human transport (including two wheel vehicles). Please do NOT use the products for vehicles designed human transport. Please contact the *Omron* sales staff for information on our automotive line of products.

4. Warranty Terms and Conditions

The terms and conditions for warranty of the products are as follows:

(1) Warranty period: *Delta Tau* warrants that products shall be free of material defects and or workmanship for a period of one year after the date of purchase.

(Excepting in the case where there is additional description in *Catalogues*)

(2) Coverage: *Delta Tau*, at its own discretion, will provide one of the following two services for malfunctioning the products:

(a) Free repair of the malfunctioning the products at a *Delta Tau* maintenance service location.

(No repair support is available for electronic components)

(b) Free replacement of the malfunctioning the products with the same number of replacement/alternative products.

(3) Exceptions: *Delta Tau* will not cover the products under its warranty if the cause of the malfunction falls under any of the following.

(a) Usage in a manner other than the original intended use for the products.

(b) Usage outside of the usage *conditions*.

(c) Usage of the product against the conditions described in "3. Precautions"

(d) Modification or repair made to the product by other than *Delta Tau* personnel.

(e) Software program embedded by other than *Delta Tau* or usage of such software.

(f) Cause which could not have been foreseen with the level of science and technology at the time of shipping from *Delta Tau*.

(g) Causes originating from other than *Delta Tau* or the products (including causes such as, but not limited to, natural disasters).

5. Limitation of Liability

The warranty set out in these Terms and Conditions is the whole and sole liability for the products. There are no other warranties, expressed or implied. *Delta Tau* and the distributors of the products are not liable for any damages which may arise from or be related to the products.

6. Export Controls

Customers of the products shall comply with all applicable laws and regulations of Japan and/or other relevant countries with regard to security export control, when exporting the products and/or technical documents or providing such products and/or documents to a non-resident. *Delta Tau* may not provide customers with the products and/or technical documents should they fail to comply with such laws and regulations.