

**Detects Intrusions into Hazardous Areas with a Single Beam and Complies with International Safety Standards.**



 Be sure to read the "Safety Precautions" on page 13.

For the most recent information on models that have been certified for safety standards, refer to your OMRON website.

## Features

**Connect to a G9SP to Create a Type 2 Safety Sensor**

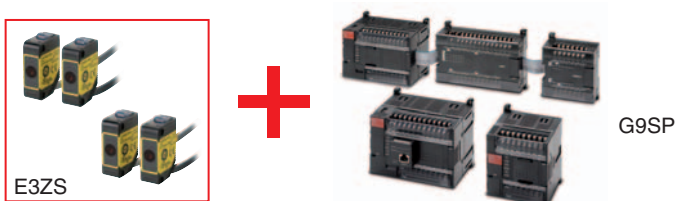

**Connects simply and easily using a wide range of accessories.**

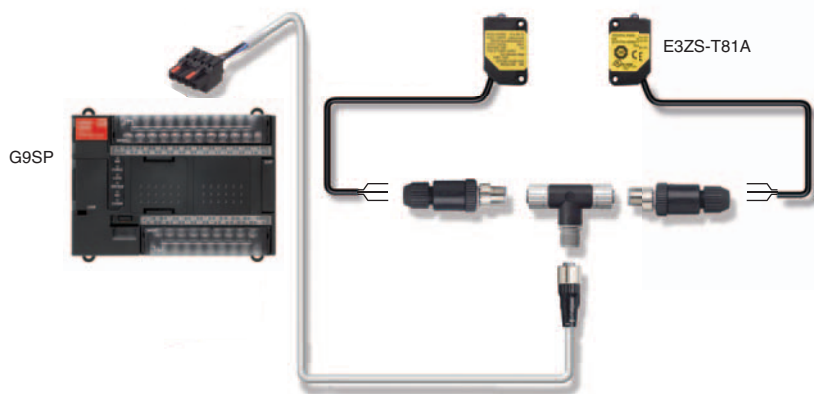

## Application Examples

### For gaps in small-sized equipment

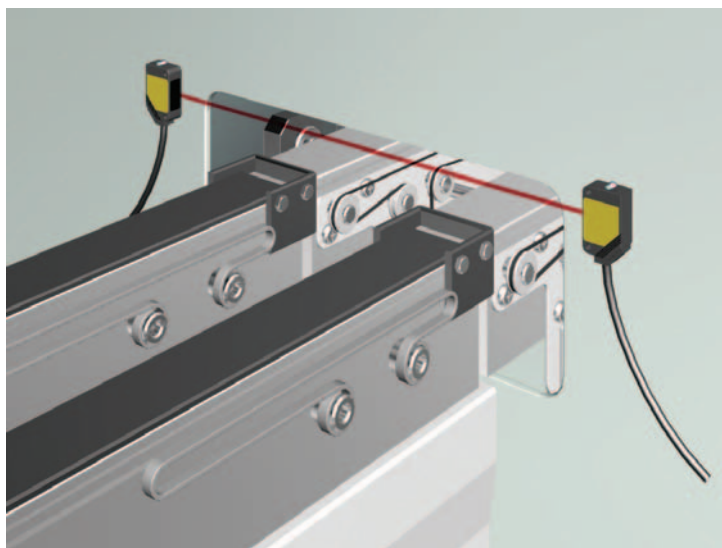

**Protect personnel from the hazards of gaps in small-sized equipment or of semi-automated machinery.**

The E3ZS is a Human Body Detection Sensor (Type 2) for production equipment. Make sure to use it in combination with an G9SP Safety Controller.

When used by itself, the E3ZS conforms to PLc/Safety Category 1 (EN ISO13849-1). No particular safety restrictions apply to the G9SP when used by itself, except the inability to use in human detection safety applications. We recommend using it in Light ON mode and using it with error detection via test input.

**Note:** Test Input

Use this function to enable the emitter of E3ZS to be turned ON/OFF from outside. It is possible to detect a number of E3ZS errors by monitoring the status of the test input and the E3ZS output signal.

### For gaps in small to medium-sized equipment





**Use as a safety measure for protection from hazardous gaps or as guards for medium-sized equipment.**

The E3ZS is a Human Body Detection Sensor (Type 2) for production equipment. Make sure to use it in combination with a G9SP Safety Controller.

## Ordering Information

### Sensors

 Red light

Sensor method	Appearance	Case material	Connection method	Sensing distance	Output	Model
Through-beam		Polybutylene terephthalate	Pre-wired cable (2 m)	 0.2 to 3 m	PNP	E3ZS-T81A

### Controller

#### Safety Controller G9SP Series

Name	No. of I/O points				Unit version	Model
	Safety inputs	Test outputs	Safety outputs	Standard outputs		
Safety Controller	10	4	Semiconductor outputs: 4	4	Ver.2.0	G9SP-N10S
	10	6	Semiconductor outputs: 16	---		G9SP-N10D
	20	6	Semiconductor outputs: 8	---		G9SP-N20S

**Note:** For details, refer to the G9SP Catalog (F090).

### Accessories

#### Branch Connector

Appearance	Model
	F39-CN3

#### Sensor Mounting Bracket

Appearance	Model
	E39-L104

## Mutual Interference Prevention Filter (for E3ZS)

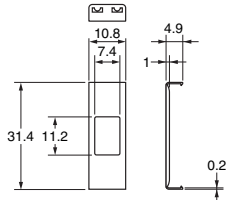
Dimensions	Model	Quantity	Remarks
	E39-E11	2 per Emitter and Receiver (4 total)	For use with E3ZS-T81A. This filter prevents mutual interference by changing the direction of polarized light of the 2 adjacent Emitter/Receivers. However, when the filter is attached, the maximum sensing distance of the E3ZS is reduced to 1.5 m.

## Cables with Connectors (Socket and Plug) on Both Ends

Type	Cable connection direction	Cable length L (m)	DC	UL standard
			Model	
Fire-retardant, robot cable	Straight/straight	1	XS2W-D421-C81-F	●
		2	XS2W-D421-D81-F	
		5	XS2W-D421-G81-F	
		10	XS2W-D421-J81-F	
	Right angle/right angle	2	XS2W-D422-D81-F	
		5	XS2W-D422-G81-F	
	Straight/right angle	2	XS2W-D423-D81-F	
		5	XS2W-D423-G81-F	
	Right angle/straight	2	XS2W-D424-D81-F	
		5	XS2W-D424-G81-F	

**Note:** Extend the cable under the following conditions.

- Overall cable length for both an E3ZS Receiver connected to an G9SP and the Emitter connected to the G9SP must be within 100 m.

## Cables with Connector (Socket) on One End

Type	Cable connection direction	Cable length L (m)	DC	UL standard
			Model	
Fire-retardant, robot cable	Straight	1	XS2F-D421-C80-F	●
		2	XS2F-D421-D80-F	
		5	XS2F-D421-G80-F	
		10	XS2F-D421-J80-F	
	Right angle	1	XS2F-D422-C80-F	
		2	XS2F-D422-D80-F	
		5	XS2F-D422-G80-F	
		10	XS2F-D422-J80-F	

**Note:** Extend the cable under the following conditions.

- Overall cable length for both an E3ZS Receiver connected to an G9SP and the Emitter connected to the G9SP must be within 100 m.

## Connector Plug Assemblies, Solder Type \*

Applicable cable diameter (mm)	Cable connection direction	Connection method	Model
3 dia. (3 to 4 dia.)	Straight	Solder	XS2G-D425
	Right angle		XS2G-D426

\* Use when connecting an E3ZS-T81A to an F39-CN3 Branch Connector.

## Connector Plug Assemblies, Screw-on Type \*

Applicable cable diameter (mm)	Cable connection direction	Connection method	Model
3 dia. (3 to 4 dia.)	Straight	Screw-on	XS2G-D4S5
	Right angle		XS2G-D4S6

\* Use when connecting an E3ZS-T81A to an F39-CN3 Branch Connector.

Accessory Connection Example

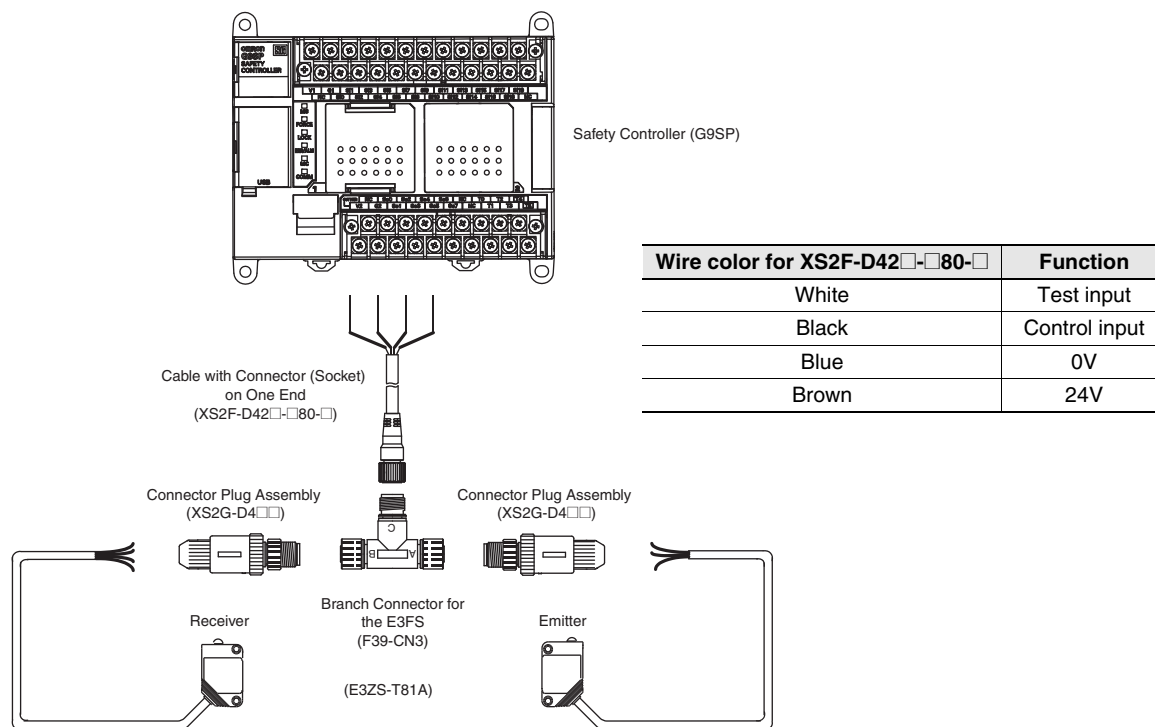

# Specifications

## E3ZS/E3FS

Item	Model	E3ZS-T81A
Sensor type		Through-beam models
Safety category		See Applicable standards.
Standard sensing object		Opaque object: 18 mm in diameter or greater
Lens diameter		Diameter 6.7 mm / diameter 9 mm
Sensing distance		0.2 to 3 m
Response time (under stable light incident condition)		1.0 ms (E3ZS only)
Startup waiting time		100 ms
Power supply voltage (Vs)		12 to 24 VDC±10% (ripple p-p 10% max.) *1
Current consumption (no load)		Emitter: 15 mA max. Receiver: 20 mA max.
Light source (emitted wavelength)		Red LED (660 nm)
Effective aperture angle (EAA)		±5° (at 3 m)
Control output (OSSD)		PNP transistor output, load current: 100 mA max., Residual voltage: 1 V max., (when load current is less than 10 mA), Residual voltage: 2 V max. (when load current is between 10 mA and 100 mA) (except for voltage drop due to cable extension) *1
Output operation mode		Light-ON *2
Input voltage		22.5 to 24 VDC: Emitter OFF (source current: 3 mA max.) Open or 0 to 2.5 V: Emitter ON (leakage current: 0.1 mA max.) *1
Indicators		Emitter: Emitting (orange); Receiver: Operation (orange), Stable (green)
Test functions		External test (light emission stop function by test input)
Connection method		Pre-wired cable (2 m)
Protective circuits		Power supply/output reverse connection protection, load short-circuit protection
Ambient temperature		Operating: -10 to 55°C Storage: -10 to 70°C (with no icing or condensation)
Ambient humidity		Operating: 35% to 85%, storage: 35% to 95% (with no icing or condensation)
Ambient operating light intensity		Incandescent lamp: 3000 lx max (light intensity on the receiver surface). Sunlight: 10,000 lx max (light intensity on the receiver surface).
Insulation resistance		20 MΩ min. (at 500 VDC)
Dielectric strength		1000 VAC 50/60 Hz 1 min
Degree of protection		IP67 (IEC standard)
Vibration resistance	Operating limit	10 to 55 Hz, double amplitude: 0.7 mm, 50 min each in the X, Y, and Z directions
	Malfunction	10 to 55 Hz, double amplitude: 1.5 mm, 2 h each in the X, Y, and Z directions
Shock resistance	Operating limit	100 m/s <sup>2</sup> , 1000 times in the X, Y, and Z directions
	Malfunction	500 m/s <sup>2</sup> , 3 times each in the X, Y, and Z directions
Material		Case: Polybutylene terephthalate
Weight (packed state)		Approx. 120 g (for one set including 2-m cable)
Accessories		Operation manual
Applicable standards	Sensor only	IEC 60947-5-3 (PDDb) EN ISO13849-1 (PLc/Safety Category 1)
	Sensor connected to G9SP	IEC(EN)61496-1 Type2 ESPE *3 IEC (EN)61496-2 Type2 AOPD *4 EN ISO13849-1 (PLc/Safety Category 2)
Switching element category (from IEC60947-5-3)		DC13 (control of electromagnetic load)

\*1. Connect the Sensor to an G9SP to use it as a safety device or as part of a safety system.

\*2. Depending on the wiring, this may turn ON when light is interrupted.

For your safety, be sure to connect the pink receiver wire (mode selection input) to 24 VDC to turn ON when light is incident.

\*3. Electro-Sensitive Protective Equipment

\*4. Active Opto-electronic Protective Device

## Connections

### Circuit Diagram Example

This section describes connecting an OMRON Safty Controller G9SP.

The OSSD 24-VDC semiconductor output from the Single Beam Safety Sensor is input.

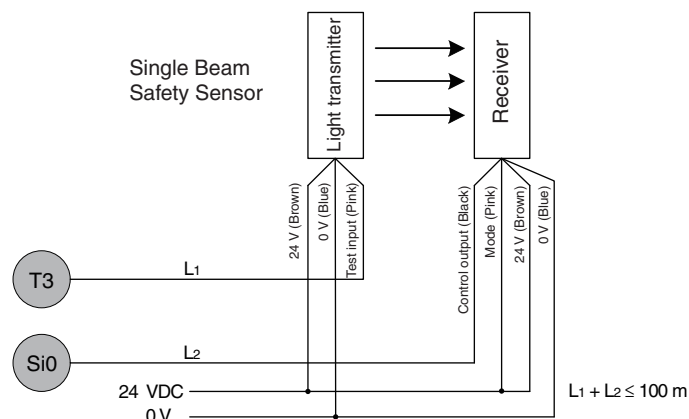

### G9SP Configurator Setting Example

Ter...	Name of settings	I/O Comment	Test Source
Si0	Single Beam Safety ...	Single Beam	T3

- Note: 1.** Only one E3ZS Single Beam Safety Sensor can be connected to a G9SP-series Safety Controller with unit version 1.0 or unit version 1.1.  
The maximum number of E3ZS Single Beam Safety Sensors that can be connected to a G9SP-series Safety Controller with unit version 2.0 or later is as follows:  
G9SP-N10S: 4 (1 Sensor · 4 systems)  
G9SP-N10D/20S: 6 (1 Sensor · 6 systems)
- The total wiring length ( $L_1 + L_2$  in the above figure) for the E3ZS/E3FS Single Beam Safety Sensor must be 100 m or less.
  - The E3ZS/E3FS Single Beam Safety Sensor can be used in a Safety Category 2 or lower, or PLC or lower application. It cannot be used in a Safety Category 3 or higher, or PLd or higher application.
  - If you use more than one Single Beam Safety Sensor, it may not be possible to detect short circuits between wires. To satisfy safety category 2, you must protect the cables to the Single Beam Safety Sensors from external damage. Use ducts, separate the cables for each system, or implement other measures to protect the cables from external damage when you connect the Single Beam Safety Sensors. You can also provide protection against short circuits by using special cables (XS2F).
  - The test period for a Single Beam Safety Sensor test is as given below. Use the value as reference to determine conformance with standards for your system.  
G9SP-N10S:  $112 \times$  Cycle time (ms)  
G9SP-N10D/20S:  $168 \times$  Cycle time (ms)

# I/O Circuit Diagrams

## E3ZS

### Circuit Diagrams (E3ZS-T81A with PNP Output)

Output mode: ON when light is incident (Light ON)

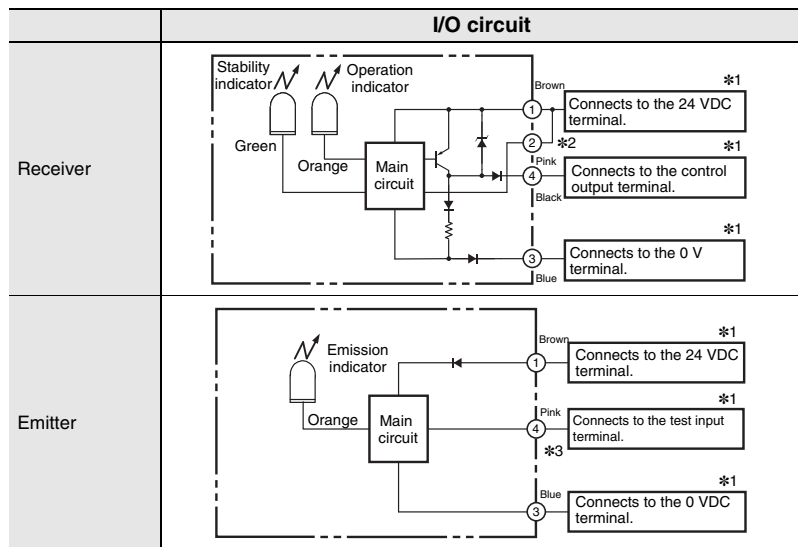

### Timing Charts

#### Output Modes and Timing Char

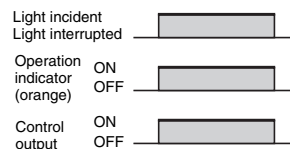

#### Emitter Timing Chart



- \*1. When using in Safety Category 2 or Type 2 ESPE configurations, make sure all terminals on a safety controller are properly connected. See the safety controller operation manual for details.
- \*2. Make sure to connect the pink wire (mode selection input 2) to 24 VDC.
- \*3. Make sure to connect to the 0V terminal when the E3ZS is not connected to a safety controller and the test input is not used.

# Engineering Data

## E3ZS

### Parallel Operating Range

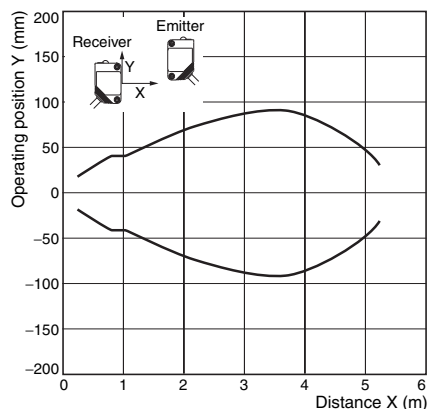

### Mutual Interference Range

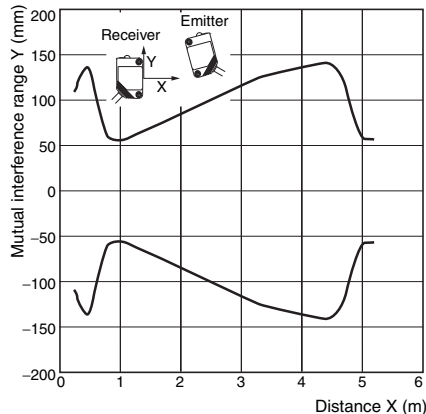

### Excess Gain Ratio

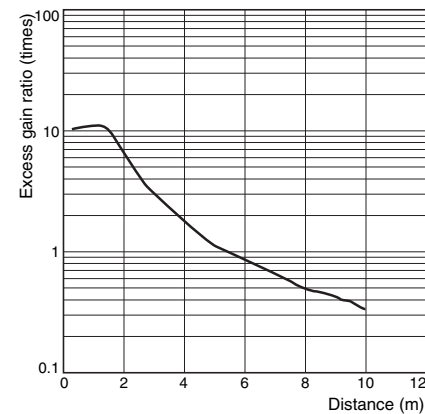



# Dimensions

## Sensors

### Pre-wired Cable with ABS Resin Case E3ZS-T81A

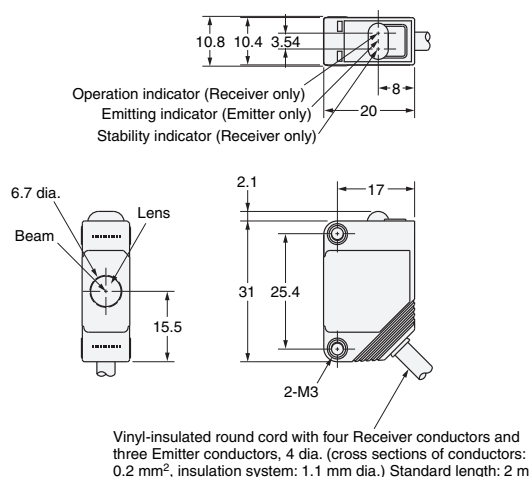

## Accessories (Order Separately)

### Branch Connector F39-CN3

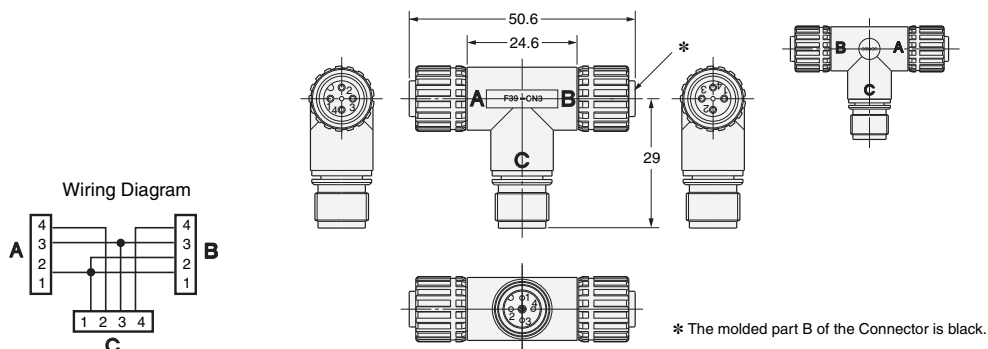

### Sensor Mounting Bracket (for E3ZS) E39-L104



Material: Stainless steel (SUS304)

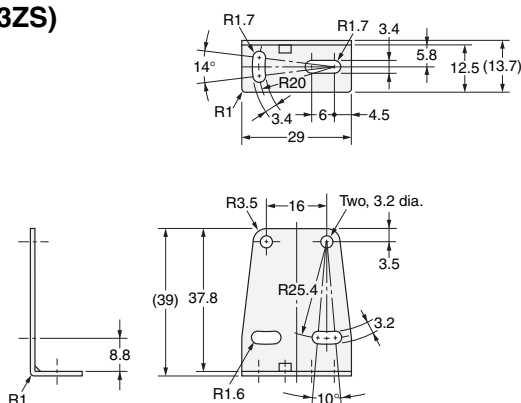

### Cables with Connectors (Socket and Plug) on Both Ends

XS2W-D421-C81-F (L=1m)

XS2W-D421-D81-F (L=2m)

XS2W-D421-G81-F (L=5m)

XS2W-D421-J81-F (L=10m)

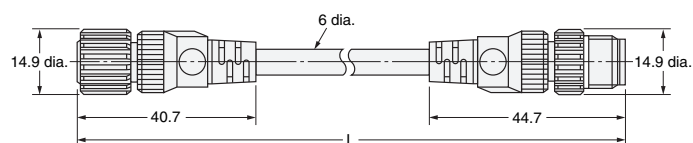

XS2W-D422-D81-F (L=2m)

XS2W-D422-G81-F (L=5m)

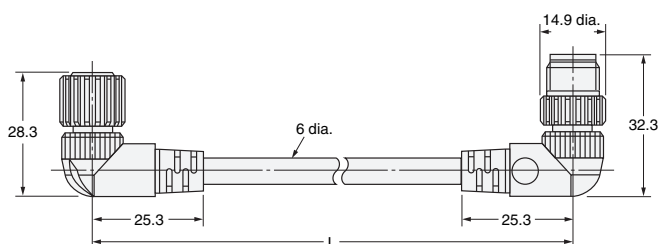

XS2W-D423-D81-F (L=2m)

XS2W-D423-G81-F (L=5m)

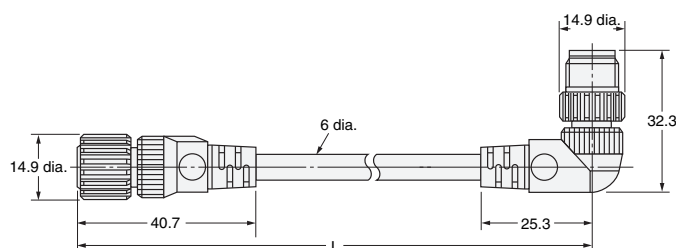

XS2W-D424-D81-F (L=2m)

XS2W-D424-G81-F (L=5m)

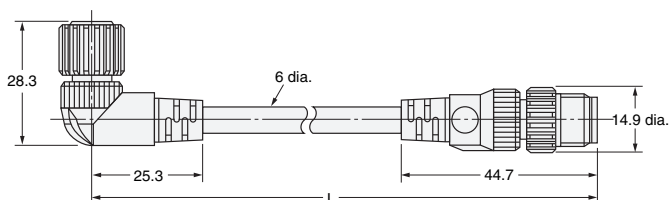

**Cables with Connector (Socket) on One End**

- XS2F-D421-C80-F (L=1m)
- XS2F-D421-D80-F (L=2m)
- XS2F-D421-G80-F (L=5m)
- XS2F-D421-J80-F (L=10m)

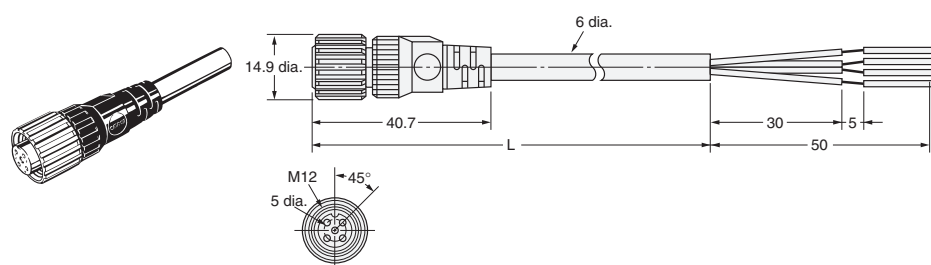

- XS2F-D422-C80-F (L=1m)
- XS2F-D422-D80-F (L=2m)
- XS2F-D422-G80-F (L=5m)
- XS2F-D422-J80-F (L=10m)

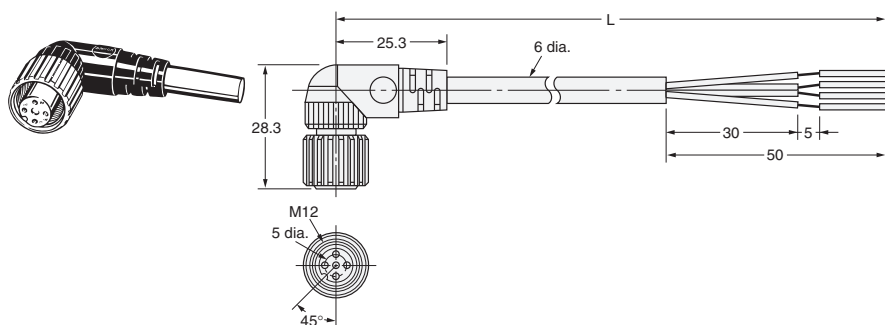

**Connector Plug Assemblies, Solder Type**

**XS2G-D425**

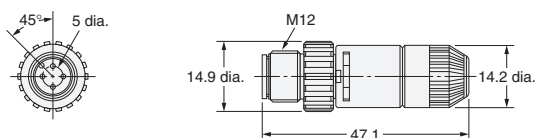
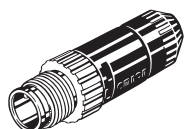

**XS2G-D426**

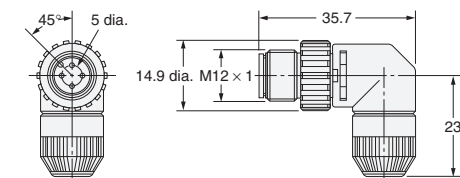
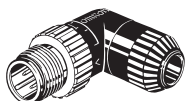

**Connector Plug Assemblies, Screw-on Type**

**XS2G-D4S5**

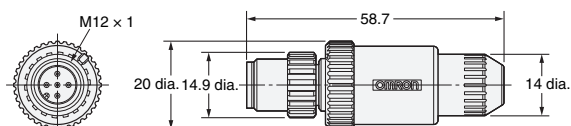
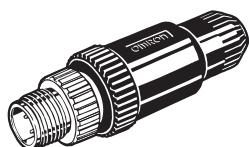

**XS2G-D4S6**

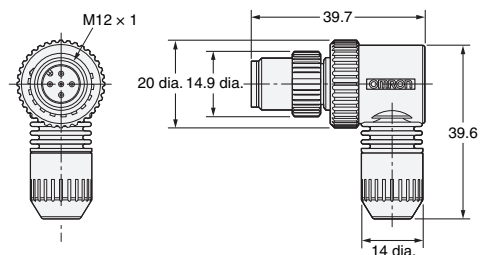
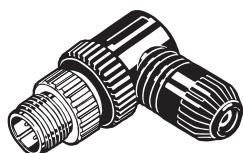

## Safety Precautions

### <Single-beam Safety Sensor E3ZS>

#### WARNING

G9SP is the only Controller that can be used for the E3ZS-T81A/E3FS-10B4□□□ (type 2). Normal operation may not be possible if another Single-beam Sensor Controller is used.



The Sensor cannot be used as part of a safety system when the mode selection input of the Single-beam Safety Sensor Receiver is connected to 0 V because the Sensor will turn ON when light is interrupted (Dark ON). Be sure to connect the mode selection input to 24 VDC if you want the Sensor to turn ON when light is incident (Light ON).



Refer to the website at: <http://www.ia.omron.com/> for calculating the Safety distance.

### Preventing Mutual Interference

Observe the following items during installation to prevent Single-beam Safety Sensors from interfering with each other or with Safety Light Curtains.

- Leave adequate space between the Sensors during installation. (Refer to the instruction manuals for the E3ZS/E3FS.)
- Use baffle plates to separate Sensors.
- Alternate Emitters and Receivers during installation. (See the figure below.)

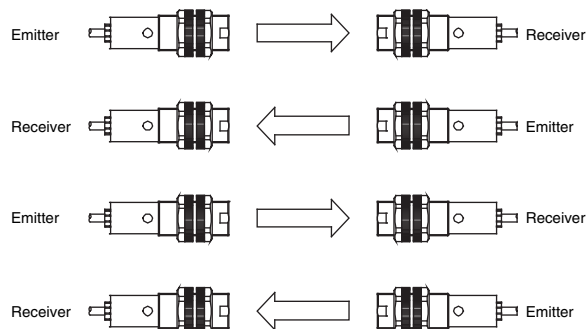

Check for mutual interference between Single-beam Safety Sensors or Safety Light Curtains connected to the same or different Control Units before finalizing placement and starting normal operation.

#### WARNING

When installing multiple Safety Light Curtains, Multi-beam Safety Sensors, and Single-beam Safety Sensors, take necessary steps to prevent mutual interference. Otherwise detection may fail and serious injury may result.



# Terms and Conditions of Sale

1. **Offer; Acceptance.** These terms and conditions (these "**Terms**") are deemed part of all quotes, agreements, purchase orders, acknowledgments, price lists, catalogs, manuals, brochures and other documents, whether electronic or in writing, relating to the sale of products or services (collectively, the "**Products**") by Omron Electronics LLC and its subsidiary companies ("**Omron**"). Omron objects to any terms or conditions proposed in Buyer's purchase order or other documents which are inconsistent with, or in addition to, these Terms.
2. **Prices; Payment Terms.** All prices stated are current, subject to change without notice by Omron. Omron reserves the right to increase or decrease prices on any unshipped portions of outstanding orders. Payments for Products are due net 30 days unless otherwise stated in the invoice.
3. **Discounts.** Cash discounts, if any, will apply only on the net amount of invoices sent to Buyer after deducting transportation charges, taxes and duties, and will be allowed only if (i) the invoice is paid according to Omron's payment terms and (ii) Buyer has no past due amounts.
4. **Interest.** Omron, at its option, may charge Buyer 1-1/2% interest per month or the maximum legal rate, whichever is less, on any balance not paid within the stated terms.
5. **Orders.** Omron will accept no order less than \$200 net billing.
6. **Governmental Approvals.** Buyer shall be responsible for, and shall bear all costs involved in, obtaining any government approvals required for the importation or sale of the Products.
7. **Taxes.** All taxes, duties and other governmental charges (other than general real property and income taxes), including any interest or penalties thereon, imposed directly or indirectly on Omron or required to be collected directly or indirectly by Omron for the manufacture, production, sale, delivery, importation, consumption or use of the Products sold hereunder (including customs duties and sales, excise, use, turnover and license taxes) shall be charged to and remitted by Buyer to Omron.
8. **Financial.** If the financial position of Buyer at any time becomes unsatisfactory to Omron, Omron reserves the right to stop shipments or require satisfactory security or payment in advance. If Buyer fails to make payment or otherwise comply with these Terms or any related agreement, Omron may (without liability and in addition to other remedies) cancel any unshipped portion of Products sold hereunder and stop any Products in transit until Buyer pays all amounts, including amounts payable hereunder, whether or not then due, which are owing to it by Buyer. Buyer shall in any event remain liable for all unpaid accounts.
9. **Cancellation; Etc.** Orders are not subject to rescheduling or cancellation unless Buyer indemnifies Omron against all related costs or expenses.
10. **Force Majeure.** Omron shall not be liable for any delay or failure in delivery resulting from causes beyond its control, including earthquakes, fires, floods, strikes or other labor disputes, shortage of labor or materials, accidents to machinery, acts of sabotage, riots, delay in or lack of transportation or the requirements of any government authority.
11. **Shipping; Delivery.** Unless otherwise expressly agreed in writing by Omron:
  - a. Shipments shall be by a carrier selected by Omron; Omron will not drop ship except in "break down" situations.
  - b. Such carrier shall act as the agent of Buyer and delivery to such carrier shall constitute delivery to Buyer;
  - c. All sales and shipments of Products shall be FOB shipping point (unless otherwise stated in writing by Omron), at which point title and risk of loss shall pass from Omron to Buyer; provided that Omron shall retain a security interest in the Products until the full purchase price is paid;
  - d. Delivery and shipping dates are estimates only; and
  - e. Omron will package Products as it deems proper for protection against normal handling and extra charges apply to special conditions.
12. **Claims.** Any claim by Buyer against Omron for shortage or damage to the Products occurring before delivery to the carrier must be presented in writing to Omron within 30 days of receipt of shipment and include the original transportation bill signed by the carrier noting that the carrier received the Products from Omron in the condition claimed.
13. **Warranties.** (a) **Exclusive Warranty.** Omron's exclusive warranty is that the Products will be free from defects in materials and workmanship for a period of twelve months from the date of sale by Omron (or such other period expressed in writing by Omron). Omron disclaims all other warranties, express or implied. (b) **Limitations.** OMRON MAKES NO WARRANTY OR REPRESENTATION, EXPRESS OR IMPLIED, ABOUT NON-INFRINGEMENT, MERCHANTABILITY OR FITNESS FOR A PARTICULAR PURPOSE OF THE PRODUCTS. BUYER ACKNOWLEDGES THAT IT ALONE HAS DETERMINED THAT THE PRODUCTS WILL SUITABLY MEET THE REQUIREMENTS OF THEIR INTENDED USE. Omron further disclaims all warranties and responsibility of any type for claims or expenses based on infringement by the Products or otherwise of any intellectual property right. (c) **Buyer Remedy.** Omron's sole obligation hereunder shall be, at Omron's election, to (i) replace (in the form originally shipped with Buyer responsible for labor charges for removal or replacement thereof) the non-complying Product, (ii) repair the non-complying Product, or (iii) repay or credit Buyer an amount equal to the purchase price of the non-complying Product; provided that in no event shall Omron be responsible for warranty, repair, indemnity or any other claims or expenses regarding the Products unless Omron's analysis confirms that the Products were properly handled, stored, installed and maintained and not subject to contamination, abuse, misuse or inappropriate modification. Return of any Products by Buyer must be approved in writing by Omron before shipment. Omron Companies shall not be liable for the suitability or unsuitability or the results from the use of Products in combination with any electrical or electronic components, circuits, system assemblies or any other materials or substances or environments. Any advice, recommendations or information given orally or in writing, are not to be construed as an amendment or addition to the above warranty. See <http://www.omron247.com> or contact your Omron representative for published information.
14. **Limitation on Liability; Etc.** OMRON COMPANIES SHALL NOT BE LIABLE FOR SPECIAL, INDIRECT, INCIDENTAL, OR CONSEQUENTIAL DAMAGES, LOSS OF PROFITS OR PRODUCTION OR COMMERCIAL LOSS IN ANY WAY CONNECTED WITH THE PRODUCTS, WHETHER SUCH CLAIM IS BASED IN CONTRACT, WARRANTY, NEGLIGENCE OR STRICT LIABILITY. Further, in no event shall liability of Omron Companies exceed the individual price of the Product on which liability is asserted.
15. **Indemnities.** Buyer shall indemnify and hold harmless Omron Companies and their employees from and against all liabilities, losses, claims, costs and expenses (including attorney's fees and expenses) related to any claim, investigation, litigation or proceeding (whether or not Omron is a party) which arises or is alleged to arise from Buyer's acts or omissions under these Terms or in any way with respect to the Products. Without limiting the foregoing, Buyer (at its own expense) shall indemnify and hold harmless Omron and defend or settle any action brought against such Companies to the extent based on a claim that any Product made to Buyer specifications infringed intellectual property rights of another party.
16. **Property; Confidentiality.** Any intellectual property in the Products is the exclusive property of Omron Companies and Buyer shall not attempt to duplicate it in any way without the written permission of Omron. Notwithstanding any charges to Buyer for engineering or tooling, all engineering and tooling shall remain the exclusive property of Omron. All information and materials supplied by Omron to Buyer relating to the Products are confidential and proprietary, and Buyer shall limit distribution thereof to its trusted employees and strictly prevent disclosure to any third party.
17. **Export Controls.** Buyer shall comply with all applicable laws, regulations and licenses regarding (i) export of products or information; (ii) sale of products to "forbidden" or other proscribed persons; and (iii) disclosure to non-citizens of regulated technology or information.
18. **Miscellaneous.** (a) **Waiver.** No failure or delay by Omron in exercising any right and no course of dealing between Buyer and Omron shall operate as a waiver of rights by Omron. (b) **Assignment.** Buyer may not assign its rights hereunder without Omron's written consent. (c) **Law.** These Terms are governed by the law of the jurisdiction of the home office of the Omron company from which Buyer is purchasing the Products (without regard to conflict of law principles). (d) **Amendment.** These Terms constitute the entire agreement between Buyer and Omron relating to the Products, and no provision may be changed or waived unless in writing signed by the parties. (e) **Severability.** If any provision hereof is rendered ineffective or invalid, such provision shall not invalidate any other provision. (f) **Setoff.** Buyer shall have no right to set off any amounts against the amount owing in respect of this invoice. (g) **Definitions.** As used herein, "including" means "including without limitation"; and "Omron Companies" (or similar words) mean Omron Corporation and any direct or indirect subsidiary or affiliate thereof.

## Certain Precautions on Specifications and Use

1. **Suitability of Use.** Omron Companies shall not be responsible for conformity with any standards, codes or regulations which apply to the combination of the Product in the Buyer's application or use of the Product. At Buyer's request, Omron will provide applicable third party certification documents identifying ratings and limitations of use which apply to the Product. This information by itself is not sufficient for a complete determination of the suitability of the Product in combination with the end product, machine, system, or other application or use. Buyer shall be solely responsible for determining appropriateness of the particular Product with respect to Buyer's application, product or system. Buyer shall take application responsibility in all cases but the following is a non-exhaustive list of applications for which particular attention must be given: (i) Outdoor use, uses involving potential chemical contamination or electrical interference, or conditions or uses not described in this document. (ii) Use in consumer products or any use in significant quantities. (iii) Energy control systems, combustion systems, railroad systems, aviation systems, medical equipment, amusement machines, vehicles, safety equipment, and installations subject to separate industry or government regulations. (iv) Systems, machines and equipment that could present a risk to life or property. Please know and observe all prohibitions of use applicable to this Product. NEVER USE THE PRODUCT FOR AN APPLICATION INVOLVING SERIOUS RISK TO LIFE OR PROPERTY OR IN LARGE QUANTITIES WITHOUT ENSURING THAT THE SYSTEM AS A WHOLE HAS BEEN DESIGNED TO ADDRESS THE RISKS, AND THAT THE OMRON'S PRODUCT IS PROPERLY RATED AND INSTALLED FOR THE INTENDED USE WITHIN THE OVERALL EQUIPMENT OR SYSTEM.
2. **Programmable Products.** Omron Companies shall not be responsible for the user's programming of a programmable Product, or any consequence thereof.
3. **Performance Data.** Data presented in Omron Company websites, catalogs and other materials is provided as a guide for the user in determining suitability and does not constitute a warranty. It may represent the result of Omron's test conditions, and the user must correlate it to actual application requirements. Actual performance is subject to the Omron's Warranty and Limitations of Liability.
4. **Change in Specifications.** Product specifications and accessories may be changed at any time based on improvements and other reasons. It is our practice to change part numbers when published ratings or features are changed, or when significant construction changes are made. However, some specifications of the Product may be changed without any notice. When in doubt, special part numbers may be assigned to fix or establish key specifications for your application. Please consult with your Omron's representative at any time to confirm actual specifications of purchased Product.
5. **Errors and Omissions.** Information presented by Omron Companies has been checked and is believed to be accurate; however, no responsibility is assumed for clerical, typographical or proofreading errors or omissions.

**OMRON AUTOMATION AND SAFETY • THE AMERICAS HEADQUARTERS** • Chicago, IL USA • 847.843.7900 • 800.556.6766 • [www.omron247.com](http://www.omron247.com)

**OMRON CANADA, INC. • HEAD OFFICE**

Toronto, ON, Canada • 416.286.6465 • 866.986.6766 • [www.omron247.com](http://www.omron247.com)

**OMRON ELECTRONICS DE MEXICO • HEAD OFFICE**

México DF • 52.55.59.01.43.00 • 01-800-226-6766 • [mela@omron.com](mailto:mela@omron.com)

**OMRON ELECTRONICS DE MEXICO • SALES OFFICE**

Apodaca, N.L. • 52.81.11.56.99.20 • 01-800-226-6766 • [mela@omron.com](mailto:mela@omron.com)

**OMRON ELETRÔNICA DO BRASIL LTDA • HEAD OFFICE**

São Paulo, SP, Brasil • 55.11.2101.6300 • [www.omron.com.br](http://www.omron.com.br)

**OMRON ARGENTINA • SALES OFFICE**

Cono Sur • 54.11.4783.5300

**OMRON CHILE • SALES OFFICE**

Santiago • 56.9.9917.3920

**OTHER OMRON LATIN AMERICA SALES**

54.11.4783.5300

**OMRON EUROPE B.V.** • Wegalaan 67-69, NL-2132 JD, Hoofddorp, The Netherlands. • +31 (0) 23 568 13 00 • [www.industrial.omron.eu](http://www.industrial.omron.eu)

*Authorized Distributor:*

**Automation Control Systems**

- Machine Automation Controllers (MAC) • Programmable Controllers (PLC)
- Operator interfaces (HMI) • Distributed I/O • Software

**Drives & Motion Controls**

- Servo & AC Drives • Motion Controllers & Encoders

**Temperature & Process Controllers**

- Single and Multi-loop Controllers

**Sensors & Vision**

- Proximity Sensors • Photoelectric Sensors • Fiber-Optic Sensors
- Amplified Photomicrosensors • Measurement Sensors
- Ultrasonic Sensors • Vision Sensors

**Industrial Components**

- RFID/Code Readers • Relays • Pushbuttons & Indicators
- Limit and Basic Switches • Timers • Counters • Metering Devices
- Power Supplies

**Safety**

- Laser Scanners • Safety Mats • Edges and Bumpers • Programmable Safety Controllers • Light Curtains • Safety Relays • Safety Interlock Switches