

Autofocus Multicode Reader and In-Line Verifier VHV5-F

High-performance barcode reader and in-line verifier.

The **VHV5-F Autofocus Multicode Reader and In-Line Verifier**, combined with the **WebLink** user interface, provides an unparalleled level of code reading performance and next-level user experience, enabling any user to easily set up the most demanding code reading applications on the factory floor.

The VHV5-F has built-in internal lighting 10 times more powerful than the MicroHAWK line of readers, as well as a 2.3 MP global shutter sensor running at 80 frames per second, and a 5 MP global shutter sensor running at 40 frames per second. A powerful quad-core processor with built-in NPU allows for near-frame rate reading speeds in most applications.

The WebLink user interface features Smart Quick Set functions to learn, optimize, and deploy in a matter of seconds in difficult static direct part mark (DPM) reading applications or very high-speed label reading applications.

The VHV5-F is pin-compatible with the MicroHAWK V430-F and V440-F readers, ensuring a clear upgrade path with all the same wiring accessories.



Features

- Smallest reader in its class.
- High-end multi-core processor (including NPU for AI). 13 times the processing power of the MicroHAWK.
- 2.3 MP (80 FPS) and 5 MP (40 FPS) global shutter sensors.
- Four autofocus lens focal length choices to cover the widest range of applications.
- Highest-power lighting on the market today.
- Third port for external lighting, compatible with most major machine vision light suppliers.
- Support for digital I/O, RS-232, Ethernet TCP/IP, EtherNet/IP™, and PROFINET communications.
- IP69K-rated.
- PoE+ or direct 24V power.

Runtime Configuration Options

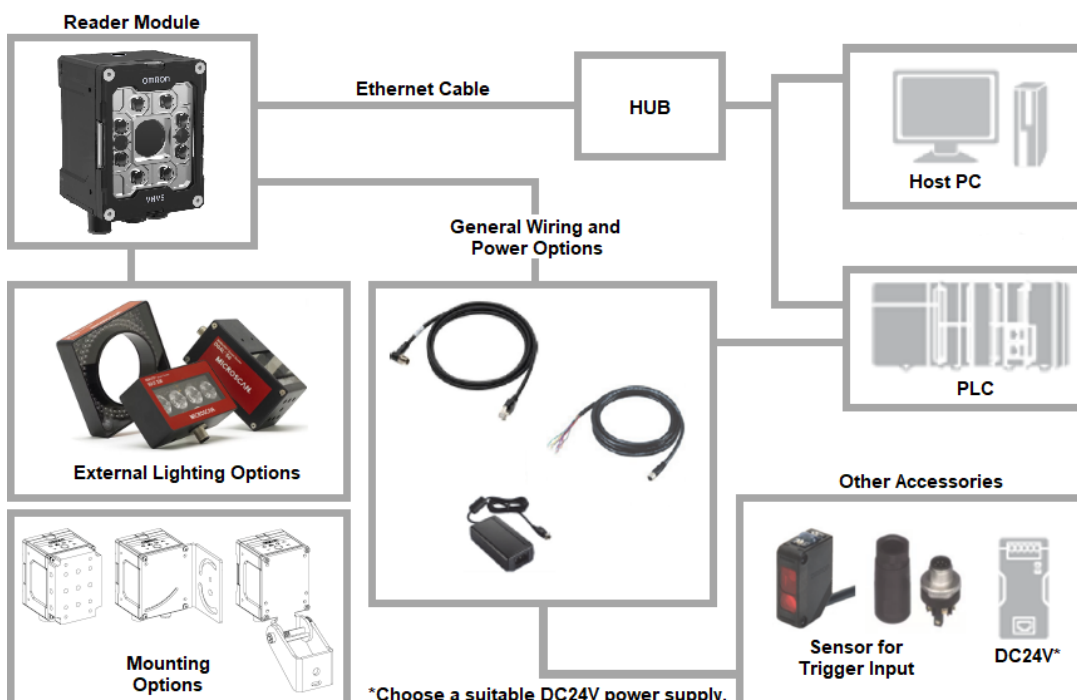

VHV5-F

Model Number Structure

Use the table below to determine the product specifications of your reader or verifier from the model number on the label.

Important: Please see the next section for the full list of orderable model numbers. All other variations should be assembled using standard models combined with available accessories.

VHV5-F – Autofocus Multicode Reader, IP69K Enclosure, 24V/PoE, Serial, Digital IO, Ethernet.

VHV5-F □□□□□□□□ - □□□□ - □
 1 2 3 4 5 6 7

No.	Classification	Code	Meaning
1	Focus Distance (mm)	000	Autofocus
		###	Focus Distance in mm
2	Lens / Field of View	W	Wide
		M	Medium
		N	Narrow
		L	Long Range
3	Sensor Type	023M	2.3 Megapixel, Monochrome, Global Shutter
		050M	5 Megapixel, Monochrome, Global Shutter
4	Front Window Filter Type	S	Clear Front Window
		D	Light-Diffusing Front Window
		P	Polarizing Window to Eliminate Glare
		H	Half-Polarizing Window (Gives the user the option to use either polarized or standard lighting in the same unit)
5	Light Color	N	None
		R	Red
		W	White
6	License	X	High-Speed X-Mode Reader
		V	High-Speed X-Mode Reader and ISO In-Line Verifier
7	Custom (0 – Z)	D	Reserved
		0 to 9, A to Z	OEMs and Large Customers

Ordering Information

Standard Orderable Reader and In-Line Verifier Models

Standard Red 2.3 MP Reader and Standard Red 5 MP Reader

Appearance	Standard Red 2.3 MP Reader	Part Number
	VHV5-F, Autofocus, Wide Lens, 2.3 MP, Standard Red Light, X-Mode Reader	VHV5-F000W023M-SRX
	VHV5-F, Autofocus, Medium Lens, 2.3 MP, Standard Red Light, X-Mode Reader	VHV5-F000M023M-SRX
	VHV5-F, Autofocus, Narrow Lens, 2.3 MP, Standard Red Light, X-Mode Reader	VHV5-F000N023M-SRX
	VHV5-F, Autofocus, Long Lens, 2.3 MP, Standard Red Light, X-Mode Reader	VHV5-F000L023M-SRX
	Standard Red 5 MP Reader	Part Number
	VHV5-F, Autofocus, Wide Lens, 5.0 MP, Standard Red Light, X-Mode Reader	VHV5-F000W050M-SRX
	VHV5-F, Autofocus, Medium Lens, 5.0 MP, Standard Red Light, X-Mode Reader	VHV5-F000M050M-SRX
	VHV5-F, Autofocus, Narrow Lens, 5.0 MP, Standard Red Light, X-Mode Reader	VHV5-F000N050M-SRX
VHV5-F, Autofocus, Long Lens, 5.0 MP, Standard Red Light, X-Mode Reader	VHV5-F000L050M-SRX	

Standard White 2.3 MP Reader and Standard White 5 MP Reader

Appearance	Standard White 2.3 MP Reader	Part Number
	VHV5-F, Autofocus, Wide Lens, 2.3 MP, Standard White Light, X-Mode Reader	VHV5-F000W023M-SWX
	VHV5-F, Autofocus, Medium Lens, 2.3 MP, Standard White Light, X-Mode Reader	VHV5-F000M023M-SWX
	VHV5-F, Autofocus, Narrow Lens, 2.3 MP, Standard White Light, X-Mode Reader	VHV5-F000N023M-SWX
	VHV5-F, Autofocus, Long Lens, 2.3 MP, Standard White Light, X-Mode Reader	VHV5-F000L023M-SWX
	Standard White 5 MP Reader	Part Number
	VHV5-F, Autofocus, Wide Lens, 5.0 MP, Standard White Light, X-Mode Reader	VHV5-F000W050M-SWX
	VHV5-F, Autofocus, Medium Lens, 5.0 MP, Standard White Light, X-Mode Reader	VHV5-F000M050M-SWX
	VHV5-F, Autofocus, Narrow Lens, 5.0 MP, Standard White Light, X-Mode Reader	VHV5-F000N050M-SWX
VHV5-F, Autofocus, Long Lens, 5.0 MP, Standard White Light, X-Mode Reader	VHV5-F000L050M-SWX	

Standard Red 2.3 MP In-Line Verifier and Standard Red 5 MP In-Line Verifier

Appearance	Standard Red 2.3 MP In-Line Verifier	Part Number
	VHV5-F, Autofocus, Medium Lens, 2.3 MP, Standard Red Light, In-Line Verifier	VHV5-F000M023M-SRV
	VHV5-F, Autofocus, Narrow Lens, 2.3 MP, Standard Red Light, In-Line Verifier	VHV5-F000N023M-SRV
	VHV5-F, Autofocus, Long Lens, 2.3 MP, Standard Red Light, In-Line Verifier	VHV5-F000L023M-SRV
	Standard Red 5 MP In-Line Verifier	Part Number
	VHV5-F, Autofocus, Medium Lens, 5.0 MP, Standard Red Light, In-Line Verifier	VHV5-F000M050M-SRV
	VHV5-F, Autofocus, Narrow Lens, 5.0 MP, Standard Red Light, In-Line Verifier	VHV5-F000N050M-SRV
	VHV5-F, Autofocus, Long Lens, 5.0 MP, Standard Red Light, In-Line Verifier	VHV5-F000L050M-SRV

Note 1: VHV5-F readers are sold without cables or mounting. These items can be found in later sections.



Note 2: The VHV5-F uses the same Parallel IO cables and interconnect accessories as the MicroHAWK V430-F and V440-F.

Note 3: X-Mode is suitable for all labels as well as low-print-grade codes and DPM.





Note 4: The wide lens is not recommended for in-line verification.

VHV5-F

Mounting Accessories

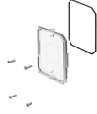
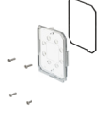
Appearance	Type	Part Number
	VHV5-F L-Bracket Adjustable Angle Mounting Kit (VHV5-F only)	VHV5-AM0
	Universal Mounting Block and Heatsink Kit (VHV5-F only)	VHV5-AM1
	VHV5-F APG Pan and Tilt Camera Mount (VHV5-F only)	VHV5-AM2

Front Window Accessories

Appearance	Type	Part Number
	VHV5-F Standard Window (for Wide and Medium Lens Models)	VHV5-AF0
	VHV5-F Lensed Window (for Narrow and Long Lens Models)	VHV5-AF1
	VHV5-F Diffuser Accessory	VHV5-AF2
	VHV5-F Polarizer Accessory	VHV5-AF3
	VHV5-F Half Polarizer Accessory	VHV5-AF4

Cables



Appearance	Category	Length / Spec	Part Number
	X-Code to RJ45 Ethernet Cable (High Flex, Straight, Black Jacket)	2 Meters	FHV-VNB2 2M
		3 Meters	FHV-VNB2 3M
		5 Meters	FHV-VNB2 5M
		10 Meters	FHV-VNB2 10M
		20 Meters	FHV-VNB2 20M
	X-Code to RJ45 Ethernet Cable (High Flex, Right-Angle, Black Jacket)	2 Meters	FHV-VNLB2 2M
		3 Meters	FHV-VNLB2 3M
		5 Meters	FHV-VNLB2 5M
		10 Meters	FHV-VNLB2 10M
		20 Meters	FHV-VNLB2 20M
	M12 to Flying Leads Cable – Parallel IO (Power, DIO, RS-232)	3 Meters	V430-W8-3M
		5 Meters	V430-W8-5M
		10 Meters	V430-W8-10M
	M12 to Flying Leads Cable – Parallel IO (Power, DIO, RS-232) – Right Angle Back	3 Meters	V430-W8LD-3M
	M12 to Flying Leads Cable – Parallel IO (Power, DIO, RS-232) – Right Angle Front	3 Meters	V430-W8LU-3M
	Reader M12 to RS-232 Breakout Cable	1 Meter	V430-WR-1M
		3 Meters	V430-WR-3M
	VHV5-F to External Light – 5 Pin M12 Plug to 5 Pin M12 Socket	1 Meter	61-000184-01
	Cable, Adapter, Omron PLC	2 Meters	V430-WPLC-2M
	Reader Interconnect Cable – M12 Socket to M12 Plug	1 Meter	V430-WQ-1M
		3 Meters	V430-WQ-3M
		5 Meters	V430-WQ-5M
	Reader Interconnect Cable with RS-232 Breakout	3 Meters	V430-WQR-3M
		5 Meters	V430-WQR-5M

***Important:** Standard Omron FJ-VSG Ethernet cables are available in alternative and longer lengths.

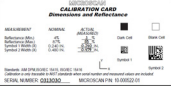
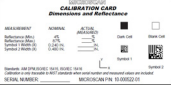
Verification Accessories

Appearance	Category	Spec	Part Number
(File)	Verification License Upgrade for VHV5-F Readers	License Key delivered as a .LIC file	LIC-0801-009
	Kit – NIST-Certified Calibration Card	NIST-Certified Calibration Card	98-000265-01
	Kit - Calibration Card	Standard Calibration Card	98-000265-02

Power Supplies

Appearance	Category	Length / Spec	Part Number
	Standard Reader 24V Power Supply (2.1 A)	1 Meter U.S. / Euro Plug	97-000012-01
	Single Port PoE Injector, 30W, IEEE802.3at Compliant, 2 x RJ45 Connector, 90 to 264VAC	Power Cord NOT Included	98-9000311-01

System Configuration Examples

Minimum Configuration to Set Up the Reader with WebLink UI

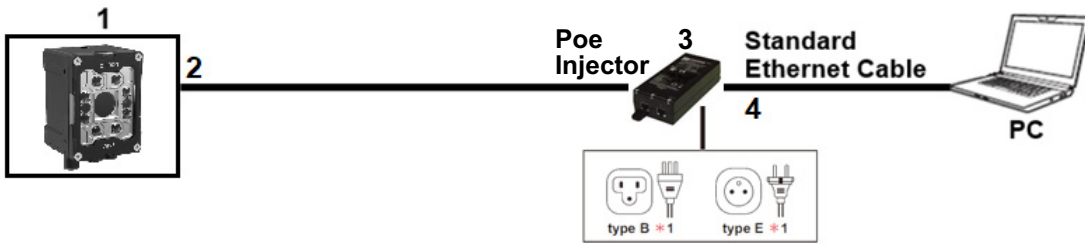

Drawing Reference	Category	Part Number
1	VHV5-F Reader or In-Line Verifier	VHV5-F□□□□□□□□-SRX or -SRV
2	Industrial GigE X-Code Ethernet Cable, M12 to RJ45 Connector	61-900013□□-0□ (Black) or FHV-VNB2, FHV-VNLB2 (Black)
3	Single Port PoE Injector, 30W, IEEE802.3at Compliant*1	98-9000311-01
4	Standard or Industrial Ethernet CAT5E or CAT6 Network Cable	Example: XS6W-5PUR8SS□□□□CM-G

*1. Power cord NOT included with 98-9000311-01. There are many types of outlet plugs for the PoE Injector (C13 connector required). Select a suitable plug type for your environment.

C13 Connector

Description	Part Number
AC Power Cable, 1.8 M, Japan, C13 Conn.	12-9001046-01
AC Power Cable, 1.8 M, U.S., C13 Conn.	12-9000959-01
AC Power Cable, 1.8 M, EU, C13 Conn.	12-9000960-01
AC Power Cable, 1.8 M, UK, C13 Conn.	12-9000961-01
AC Power Cable, 1.8 M, China, C13 Conn.	12-9000962-01

Minimum Power over Ethernet (PoE) Configuration

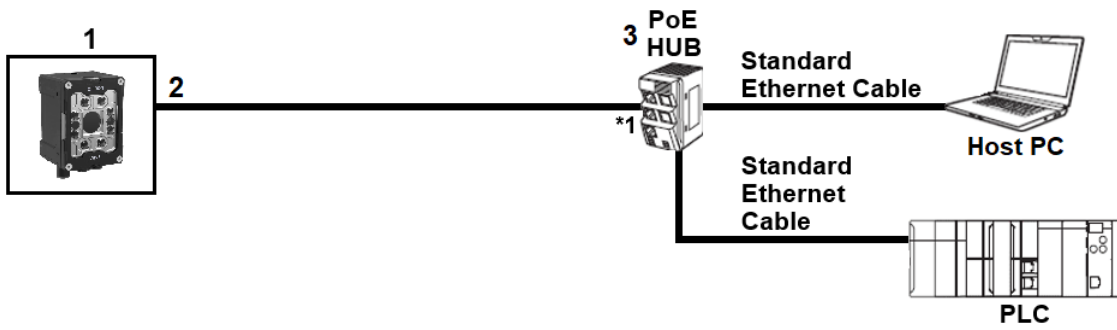

Drawing Reference	Category	Part Number
1	VHV5-F Reader or In-Line Verifier	VHV5-F□□□□□□□□-SRX or -SRV
2	Industrial GigE X-Code Ethernet Cable, M12 to RJ45 Connector	61-900013□□-0□ (Black) or FHV-VNB2, FHV-VNLB2 (Black)
3	PoE (Power over Ethernet) HUB that supports Power over Ethernet (IEEE 802.3at-compliant)	Example: Cisco, Netgear, etc.

*1. A 24VDC power supply is not needed for the VHV5-F if a PoE switching HUB is used.

Minimum Direct Power Configuration

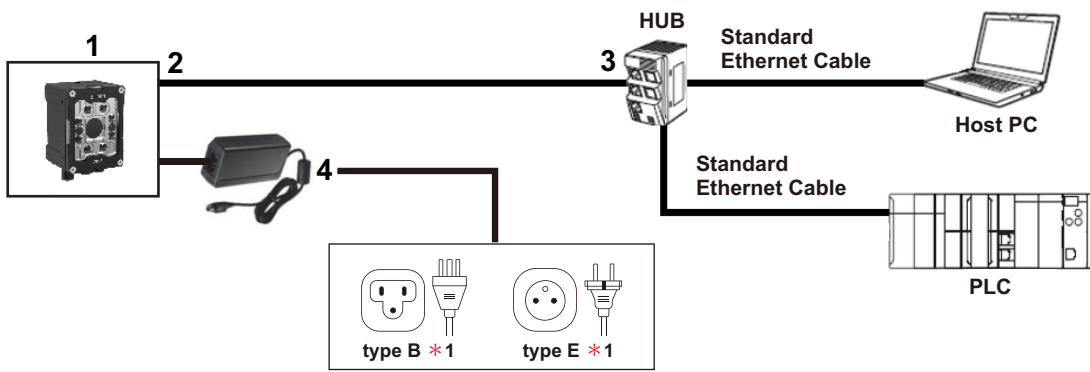

Drawing Reference	Category	Part Number
1	VHV5-F Reader or In-Line Verifier	VHV5-F□□□□□□□□-SRX or -SRV
2	Industrial GigE X-Code Ethernet Cable, M12 to RJ45 Connector	61-900013□-0□ (Black) or FHV-VNB2, FHV-VNLB2 (Black)
3	Industrial Switching HUB	Example: W4S1-□□□ Series
4	Power Supply, 100-240VAC, +24VDC @ 2.1A, M12 12-Pin Socket*1	97-000012-01

*1. There are many types of outlet plugs for the power supply (C13 connector required). Select a suitable plug type for your environment.

C13 Connector

Description	Part Number
AC Power Cable, 1.8 M, Japan, C13 Conn.	12-9001046-01
AC Power Cable, 1.8 M, U.S., C13 Conn.	12-9000959-01
AC Power Cable, 1.8 M, EU, C13 Conn.	12-9000960-01
AC Power Cable, 1.8 M, UK, C13 Conn.	12-9000961-01
AC Power Cable, 1.8 M, China, C13 Conn.	12-9000962-01

Direct Power Configuration with External Light

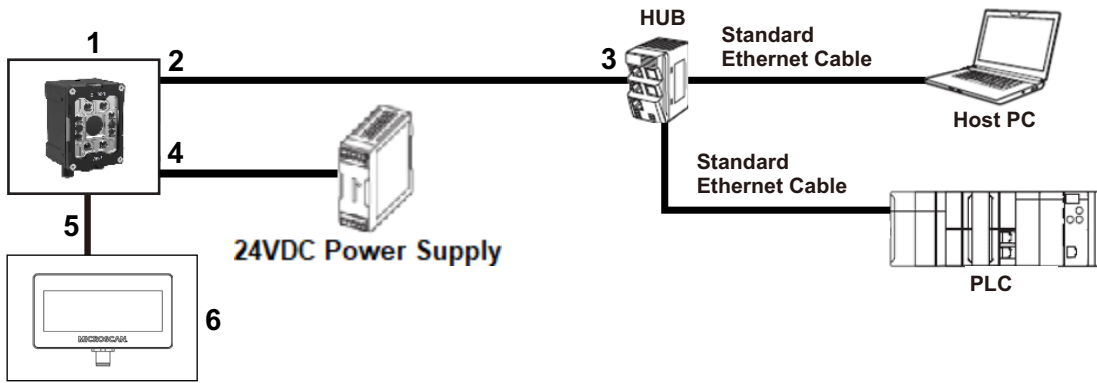

Drawing Reference	Category	Part Number
1	VHV5-F Reader or In-Line Verifier	VHV5-F□□□□□□□□-SRX or -SRV
2	Industrial GigE X-Code Ethernet Cable, M12 to RJ45 Connector	61-900013□-0□ (Black) or FHV-VNB2, FHV-VNLB2 (Black)
3	Industrial Switching HUB	Example: W4S1-□□□ Series
4	M12-to-Flying Leads Cable	V430-W8□□□-□M
5	VHV5-F to External Light – 5 Pin M12 Plug to 5 Pin M12 Socket	61-000184-01
6	NERLITE Smart Series Light (Example: Smart Series MAX, 100 mm, Red, M12 Connector)	Example: NER-011660201G

Important: Must use direct 24V power when using external light option to ensure adequate power to run the light and reader.

RS-232C Configuration

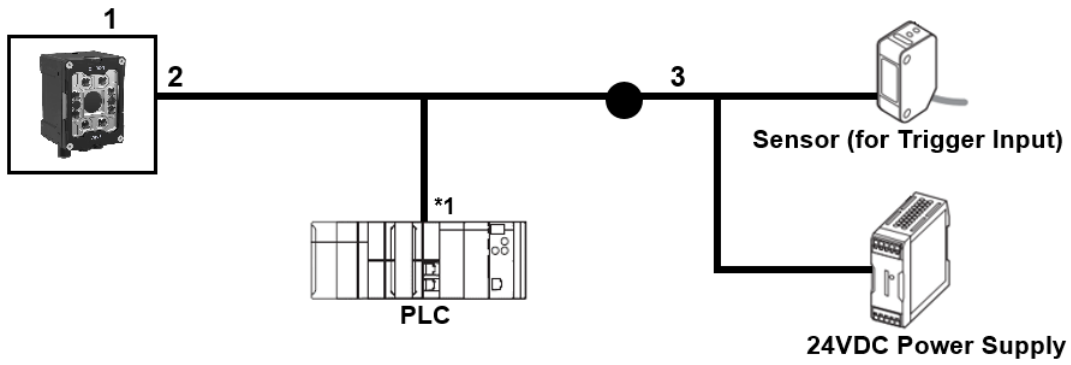

Drawing Reference	Category	Part Number
1	VHV5-F Reader or In-Line Verifier	VHV5-F□□□□□□□□-SRX or -SRV
2	Reader Interconnect Cable with RS-232 Breakout	V430-WQR-3M ^{*1}
3	M12-to-Flying Leads Cable	V430-W8□□□□-□M
4	RS-232C Conversion Cable Required for Legacy Omron PLCs	V430-WPLC-2M ^{*2}

*1. Insert the V430-WQR-3M cable between the VHV5-F and the V430-W8□□□□-□M cable.

*2. When connecting Omron's CS/CJ/NJ Legacy Controller, the additional RS-232C conversion cable is required. If connecting to Omron's current-generation NX Machine Automation Controller, no additional RS-232C cable is required.

VHV5-F

Determine the Correct Reader Model for the Application

There are eight basic models of the autofocus VHV5-F. The models are derived from two sensor resolutions: **2.3 MP** and **5.0 MP**; and four different autofocus lenses: **Wide, Medium, Narrow, and Long**. The charts below show the key specifications for the two sensors and four lenses.

Sensor	Pixels	Pixel Size	Frame Rate
2.3 MP	1920 x 1200	3.0 µm	80 FPS
5.0 MP	2472 x 2048	2.74 µm	40 FPS

Lens Name	Lens Focal Length (mm)	Focus Range (mm)
Wide	6.42	55-500
Medium	8.50	55-500
Narrow	12.50	100-1,000
Long	20.00	100-2,000

These models, derived from the two sensor types and four lens types, provide maximum flexibility to match the reader to the application.

Step 1 – The first step in determining the correct model is to evaluate the application by collecting key pieces of information. This process is described in the section below titled "Evaluate the Application".

Step 2 – The second step is to use that data to look up the best sensor / lens combination in the "Distance, Field of View and Readability Tables" section below that best satisfies the application requirements.

Evaluate the Application

To choose the correct reader, perform an application evaluation and gather the following information:

- **Desired Mounting Distance** – Measured from the front of the reader to the code. Distance is usually dictated by mounting constraints.
- **Required Field of View** – View area required to see all codes. This should include the nominal code position, size, and expected variation in position while running.
- **Code Type** – Either 1D or 2D. Composite codes count as 2D.
- **Code Quality** – Two levels: (1.) High-quality, high-contrast codes. (2.) Lower-quality, lower-contrast codes marked with laser, dot peen, etc., generally referred to as direct part marks (DPM).
- **Code Size (Mils)** – For 1D codes, code size is the width of the narrowest bar in the code. For 2D codes, code size is the width / height of an individual cell or block (square element) in the code. Code size is typically specified in Mils, where 1 Mil = 1/1,000th of an inch. (0.0254 mm).
- **Code Color** – Code color can sometimes be a consideration. The most common light color for code readers is red. However, in the case of red print, Red light will cause the red print to disappear. The user should take this into consideration and order the unit with white LEDs instead.

Key Point: Code Size is not the overall size of the code, but is the size of the smallest element in the code. The example below shows that for 1D codes, the Code size specified as the width of the thinnest bar or space. For 2D codes, Code Size is the width / height of one of the black or white squares.



1D Barcode



2D Code

Choose the Model

The readability tables below show the sensor/lens combinations for VHV5-F models. For each reader-to-part distance, the tables show the resulting field of view, as well as the smallest code size that can be decoded reliably at that Distance in that Field of View.

Use the distance and field of view requirements determined in your application evaluation to choose the model that will provide the highest resolution for reading your Code Type (1D or 2D) and Code Quality (High-Contrast Label quality, Lower Contrast, DPM quality).

Note: Codes with sizes that are larger than the stated minimum can be assumed to be readable.

The following chart shows how the minimum code sizes in the readability tables have been determined. High-contrast (label-quality) marks need fewer pixels per element (lower PPE) to be decoded reliably. Low-print-quality and DPM (direct part mark) codes often require a higher PPE to get the same high read rates. Code grading, which involves actual measurements of the cells themselves, requires an even higher PPE.

Code Type	Minimum PPE	Preferred PPE	PPE for Code Grading
1D Code – Label Quality	1.6	2	6 to 8
1D Code – Direct Part Mark	2	2.5	6 to 8
2D Code – Label Quality	2.75	3.5 to 5	8 to 10
2D Code – Direct Part Mark	3.5	4 to 5	8 to 10

Distance, Field of View, and Readability Tables

Use the following tables to identify the Sensor/Lens combination that most closely matches the reader application requirements. The tables below use the Minimum PPE value from the table above.

Example: If the Code Type is a 2D DPM, and the Code Size is 15 mils, the Medium Lens table below shows that a code as small as 13.9 Mils can be read out to 250 mm, in a field of view of 181 x 113 mm.

2.3 MP Sensor Readability Tables

Wide Lens – 2.3 MP		Minimum Readable Code Size				
Distance [mm]	Field of View [mm x mm]	1D Label [Mils (mm)]	1D DPM [Mils (mm)]	2D Label [Mils (mm)]	2D DPM [Mils (mm)]	1D/2D for Max FOV [Mils (mm)]*
55	68 x 43	2.1 (0.053)	2.6 (0.066)	3.6 (0.091)	4.6 (0.116)	4.6 (0.117)
75	88 x 55	2.7 (0.068)	3.3 (0.085)	4.6 (0.117)	5.9 (0.149)	4.9 (0.124)
100	111 x 70	3.4 (0.087)	4.3 (0.108)	5.9 (0.149)	7.5 (0.190)	5.2 (0.132)
150	159 x 99	4.9 (0.124)	6.1 (0.155)	8.4 (0.213)	10.7 (0.271)	5.9 (0.150)
200	207 x 129	6.4 (0.161)	7.9 (0.202)	10.9 (0.278)	13.9 (0.353)	6.8 (0.173)
250	254 x 159	7.8 (0.199)	9.8 (0.249)	13.5 (0.342)	17.1 (0.435)	7.8 (0.198)
300	302 x 189	9.3 (0.236)	11.6 (0.295)	16.0 (0.406)	20.3 (0.517)	8.9 (0.226)
350	350 x 219	10.8 (0.274)	13.5 (0.342)	18.5 (0.470)	23.6 (0.599)	10.1 (0.257)
400	398 x 249	12.2 (0.311)	15.3 (0.389)	21.0 (0.535)	26.8 (0.680)	11.3 (0.287)
450	445 x 278	13.7 (0.348)	17.1 (0.436)	23.6 (0.599)	30.0 (0.762)	12.5 (0.318)
500	493 x 308	15.2 (0.386)	19.0 (0.482)	26.1 (0.663)	33.2 (0.844)	13.7 (0.348)

*Recommended minimum code size for optimal performance at the edges of the field of view (FOV).

Medium Lens – 2.3 MP		Minimum Readable Code Size			
Distance [mm]	Field of View [mm x mm]	1D Label [Mils (mm)]	1D DPM [Mils (mm)]	2D Label [Mils (mm)]	2D DPM [Mils (mm)]
55	48 x 30	1.6 (0.040)	2.0 (0.051)	2.7 (0.069)	3.5 (0.088)
75	62 x 39	2.0 (0.052)	2.5 (0.065)	3.5 (0.089)	4.5 (0.113)
100	79 x 49	2.6 (0.066)	3.2 (0.082)	4.5 (0.113)	5.7 (0.144)
200	147 x 92	4.8 (0.122)	6.0 (0.153)	8.3 (0.210)	10.5 (0.268)
250	181 x 113	5.9 (0.151)	7.4 (0.188)	10.2 (0.259)	13.0 (0.329)
300	215 x 134	7.0 (0.179)	8.8 (0.223)	12.1 (0.307)	15.4 (0.391)
350	248 x 155	8.1 (0.207)	10.2 (0.259)	14.0 (0.356)	17.8 (0.453)
400	282 x 176	9.3 (0.235)	11.6 (0.294)	15.9 (0.404)	20.3 (0.515)
450	316 x 198	10.4 (0.263)	13.0 (0.329)	17.8 (0.453)	22.7 (0.576)
500	350 x 219	11.5 (0.292)	14.4 (0.365)	19.7 (0.501)	25.1 (0.638)

Narrow Lens – 2.3 MP		Minimum Readable Code Size			
Distance [mm]	Field of View [mm x mm]	1D Label [Mils (mm)]	1D DPM [Mils (mm)]	2D Label [Mils (mm)]	2D DPM [Mils (mm)]
100	50 x 31	1.6 (0.042)	2.1 (0.052)	2.8 (0.072)	3.6 (0.092)
150	73 x 46	2.4 (0.061)	3.0 (0.076)	4.1 (0.105)	5.3 (0.134)
200	96 x 60	3.2 (0.080)	3.9 (0.100)	5.4 (0.138)	6.9 (0.176)
250	119 x 75	3.9 (0.099)	4.9 (0.124)	6.7 (0.171)	8.6 (0.218)
300	142 x 89	4.7 (0.119)	5.8 (0.148)	8.0 (0.204)	10.2 (0.260)
350	165 x 103	5.4 (0.138)	6.8 (0.172)	9.3 (0.237)	11.9 (0.302)
400	188 x 118	6.2 (0.157)	7.7 (0.196)	10.6 (0.270)	13.5 (0.344)
450	212 x 132	6.9 (0.176)	8.7 (0.220)	11.9 (0.303)	15.2 (0.386)
500	235 x 147	7.7 (0.195)	9.6 (0.244)	13.2 (0.336)	16.8 (0.428)
600	281 x 175	9.2 (0.234)	11.5 (0.292)	15.8 (0.402)	20.1 (0.512)
700	327 x 204	10.7 (0.272)	13.4 (0.340)	18.4 (0.468)	23.4 (0.596)
800	373 x 233	12.2 (0.311)	15.3 (0.388)	21.0 (0.534)	26.8 (0.680)
900	419 x 262	13.7 (0.349)	17.2 (0.436)	23.6 (0.600)	30.1 (0.764)
1000	465 x 291	15.3 (0.387)	19.1 (0.484)	26.2 (0.666)	33.4 (0.848)

Long Lens – 2.3 MP		Minimum Readable Code Size			
Distance [mm]	Field of View [mm x mm]	1D Label [Mils (mm)]	1D DPM [Mils (mm)]	2D Label [Mils (mm)]	2D DPM [Mils (mm)]
100	29 x 18	1.2 (0.029)	1.3 (0.033)	1.8 (0.045)	2.3 (0.057)
150	42 x 27	1.7 (0.043)	1.9 (0.048)	2.6 (0.066)	3.3 (0.083)
200	56 x 35	2.2 (0.056)	2.5 (0.063)	3.4 (0.086)	4.3 (0.110)
250	69 x 43	2.8 (0.070)	3.1 (0.078)	4.2 (0.107)	5.4 (0.136)
300	83 x 52	3.3 (0.083)	3.6 (0.093)	5.0 (0.127)	6.4 (0.162)
350	96 x 60	3.8 (0.097)	4.2 (0.108)	5.8 (0.148)	7.4 (0.188)
400	109 x 68	4.3 (0.110)	4.8 (0.123)	6.6 (0.169)	8.5 (0.215)
450	123 x 77	4.9 (0.124)	5.4 (0.138)	7.5 (0.189)	9.5 (0.241)
500	136 x 85	5.4 (0.137)	6.0 (0.153)	8.3 (0.210)	10.5 (0.267)
600	163 x 102	6.5 (0.164)	7.2 (0.183)	9.9 (0.251)	12.6 (0.320)
700	190 x 118	7.5 (0.191)	8.4 (0.213)	11.5 (0.292)	14.7 (0.372)
800	216 x 135	8.6 (0.218)	9.6 (0.243)	13.1 (0.334)	16.7 (0.425)
900	243 x 152	9.7 (0.245)	10.7 (0.273)	14.8 (0.375)	18.8 (0.477)
1000	270 x 169	10.7 (0.272)	11.9 (0.303)	16.4 (0.416)	20.9 (0.530)
1100	297 x 185	11.8 (0.299)	13.1 (0.333)	18.0 (0.457)	22.9 (0.582)
1200	323 x 202	12.9 (0.326)	14.3 (0.363)	19.6 (0.499)	25.0 (0.635)
1300	350 x 219	13.9 (0.353)	15.5 (0.393)	21.3 (0.540)	27.1 (0.687)
1400	377 x 236	15.0 (0.380)	16.6 (0.423)	22.9 (0.581)	29.1 (0.740)
1500	404 x 252	16.0 (0.407)	17.8 (0.453)	24.5 (0.622)	31.2 (0.792)
1600	430 x 269	17.1 (0.434)	19.0 (0.483)	26.1 (0.664)	33.3 (0.845)
1700	457 x 286	18.2 (0.461)	20.2 (0.513)	27.8 (0.705)	35.3 (0.897)
1800	484 x 302	19.2 (0.488)	21.4 (0.543)	29.4 (0.746)	37.4 (0.950)
1900	511 x 319	20.3 (0.515)	22.5 (0.573)	31.0 (0.787)	39.5 (1.002)
2000	537 x 336	21.4 (0.542)	23.7 (0.603)	32.6 (0.829)	41.5 (1.055)

5.0 MP Sensor Readability Tables

Wide Lens – 5 MP		Minimum Readable Code Size				
Distance [mm]	Field of View [mm x mm]	1D Label [Mils (mm)]	1D DPM [Mils (mm)]	2D Label [Mils (mm)]	2D DPM [Mils (mm)]	1D/2D for max FOV [Mils (mm)]*
55	81 x 67	1.9 (0.048)	2.4 (0.061)	3.3 (0.083)	4.2 (0.106)	6.9 (0.175)
75	104 x 86	2.4 (0.062)	3.1 (0.078)	4.2 (0.107)	5.4 (0.136)	7.3 (0.185)
100	133 x 110	3.1 (0.079)	3.9 (0.099)	5.4 (0.136)	6.8 (0.173)	7.5 (0.191)
150	189 x 157	4.5 (0.113)	5.6 (0.142)	7.7 (0.195)	9.8 (0.248)	7.8 (0.198)
200	246 x 204	5.8 (0.147)	7.3 (0.184)	10.0 (0.254)	12.7 (0.323)	8.4 (0.213)
250	303 x 251	7.2 (0.182)	8.9 (0.227)	12.3 (0.312)	15.6 (0.397)	9.1 (0.231)
300	360 x 298	8.5 (0.216)	10.6 (0.270)	14.6 (0.371)	18.6 (0.472)	10.1 (0.257)
350	416 x 345	9.8 (0.250)	12.3 (0.312)	16.9 (0.430)	21.5 (0.547)	11.2 (0.284)
400	473 x 392	11.2 (0.284)	14.0 (0.355)	19.2 (0.488)	24.5 (0.621)	12.5 (0.318)
450	530 x 439	12.5 (0.318)	15.7 (0.398)	21.5 (0.547)	27.4 (0.696)	13.8 (0.351)
500	587 x 486	13.9 (0.352)	17.3 (0.440)	23.8 (0.606)	30.3 (0.771)	15.1 (0.384)

*Recommended minimum code size for optimal performance at the edges of the field of view (FOV).

Medium Lens – 5 MP		Minimum Readable Code Size			
Distance [mm]	Field of View [mm x mm]	1D Label [Mils (mm)]	1D DPM [Mils (mm)]	2D Label [Mils (mm)]	2D DPM [Mils (mm)]
55	56 x 47	1.5 (0.037)	1.8 (0.046)	2.5 (0.063)	3.2 (0.081)
75	72 x 60	1.9 (0.047)	2.3 (0.059)	3.2 (0.081)	4.1 (0.103)
100	92 x 77	2.4 (0.060)	3.0 (0.075)	4.1 (0.103)	5.2 (0.132)
150	131 x 110	3.4 (0.086)	4.2 (0.107)	5.8 (0.148)	7.4 (0.188)
200	171 x 143	4.4 (0.112)	5.5 (0.140)	7.6 (0.192)	9.6 (0.244)
250	210 x 176	5.4 (0.137)	6.8 (0.172)	9.3 (0.236)	11.8 (0.301)
300	250 x 209	6.4 (0.163)	8.0 (0.204)	11.0 (0.281)	14.1 (0.357)
350	289 x 242	7.4 (0.189)	9.3 (0.236)	12.8 (0.325)	16.3 (0.414)
400	329 x 275	8.5 (0.215)	10.6 (0.269)	14.5 (0.369)	18.5 (0.470)
450	368 x 308	9.5 (0.241)	11.8 (0.301)	16.3 (0.414)	20.7 (0.526)
500	408 x 341	10.5 (0.266)	13.1 (0.333)	18.0 (0.458)	22.9 (0.583)

Narrow Lens – 5 MP –		Minimum Readable Code Size			
Distance [mm]	Field of View [mm x mm]	1D Label [Mils (mm)]	1D DPM [Mils (mm)]	2D Label [Mils (mm)]	2D DPM [Mils (mm)]
100	58 x 49	1.5 (0.038)	1.9 (0.048)	2.6 (0.066)	3.3 (0.084)
150	85 x 71	2.2 (0.056)	2.7 (0.070)	3.8 (0.096)	4.8 (0.122)
200	112 x 94	2.9 (0.073)	3.6 (0.092)	5.0 (0.126)	6.3 (0.160)
250	139 x 116	3.6 (0.091)	4.5 (0.114)	6.1 (0.156)	7.8 (0.199)
300	166 x 139	4.3 (0.108)	5.3 (0.135)	7.3 (0.186)	9.3 (0.237)
350	193 x 161	5.0 (0.126)	6.2 (0.157)	8.5 (0.216)	10.8 (0.275)
400	219 x 184	5.6 (0.143)	7.1 (0.179)	9.7 (0.247)	12.4 (0.314)
450	246 x 206	6.3 (0.161)	7.9 (0.201)	10.9 (0.277)	13.9 (0.352)
500	273 x 229	7.0 (0.179)	8.8 (0.223)	12.1 (0.307)	15.4 (0.391)
600	327 x 273	8.4 (0.214)	10.5 (0.267)	14.5 (0.367)	18.4 (0.467)
700	380 x 318	9.8 (0.249)	12.2 (0.311)	16.8 (0.427)	21.4 (0.544)
800	434 x 363	11.2 (0.284)	14.0 (0.355)	19.2 (0.488)	24.4 (0.621)
900	488 x 408	12.6 (0.319)	15.7 (0.399)	21.6 (0.548)	27.5 (0.697)
1000	541 x 453	13.9 (0.354)	17.4 (0.442)	23.9 (0.608)	30.5 (0.774)

Long Lens – 5 MP		Minimum Readable Code Size			
Distance [mm]	Field of View [mm x mm]	1D Label [Mils (mm)]	1D DPM [Mils (mm)]	2D Label [Mils (mm)]	2D DPM [Mils (mm)]
100	34 x 28	1.0 (0.027)	1.2 (0.030)	1.6 (0.041)	2.1 (0.052)
150	49 x 41	1.5 (0.039)	1.7 (0.044)	2.4 (0.060)	3.0 (0.076)
200	65 x 54	2.0 (0.051)	2.3 (0.057)	3.1 (0.079)	3.9 (0.100)
250	80 x 67	2.5 (0.063)	2.8 (0.071)	3.8 (0.098)	4.9 (0.124)
300	96 x 79	3.0 (0.075)	3.3 (0.085)	4.6 (0.116)	5.8 (0.148)
350	111 x 92	3.5 (0.088)	3.9 (0.098)	5.3 (0.135)	6.8 (0.172)

Long Lens – 5 MP		Minimum Readable Code Size			
Distance [mm]	Field of View [mm x mm]	1D Label [Mils (mm)]	1D DPM [Mils (mm)]	2D Label [Mils (mm)]	2D DPM [Mils (mm)]
400	127 x 105	3.9 (0.100)	4.4 (0.112)	6.1 (0.154)	7.7 (0.196)
450	142 x 118	4.4 (0.112)	5.0 (0.126)	6.8 (0.173)	8.7 (0.220)
500	158 x 131	4.9 (0.124)	5.5 (0.139)	7.5 (0.192)	9.6 (0.244)
600	189 x 156	5.9 (0.149)	6.6 (0.167)	9.0 (0.229)	11.5 (0.292)
700	220 x 182	6.8 (0.173)	7.6 (0.194)	10.5 (0.267)	13.4 (0.340)
800	251 x 208	7.8 (0.198)	8.7 (0.222)	12.0 (0.305)	15.3 (0.388)
900	282 x 234	8.7 (0.222)	9.8 (0.249)	13.5 (0.342)	17.2 (0.436)
1000	313 x 259	9.7 (0.246)	10.9 (0.276)	15.0 (0.380)	19.0 (0.484)
1100	344 x 285	10.7 (0.271)	12.0 (0.304)	16.4 (0.418)	20.9 (0.532)
1200	375 x 311	11.6 (0.295)	13.0 (0.331)	17.9 (0.455)	22.8 (0.580)
1300	406 x 336	12.6 (0.320)	14.1 (0.359)	19.4 (0.493)	24.7 (0.628)
1400	437 x 362	13.5 (0.344)	15.2 (0.386)	20.9 (0.531)	26.6 (0.676)
1500	468 x 388	14.5 (0.368)	16.3 (0.413)	22.4 (0.568)	28.5 (0.724)
1600	499 x 413	15.5 (0.393)	17.4 (0.441)	23.9 (0.606)	30.4 (0.771)
1700	530 x 439	16.4 (0.417)	18.4 (0.468)	25.3 (0.644)	32.3 (0.819)
1800	561 x 465	17.4 (0.442)	19.5 (0.496)	26.8 (0.682)	34.1 (0.867)
1900	592 x 491	18.4 (0.466)	20.6 (0.523)	28.3 (0.719)	36.0 (0.915)
2000	623 x 516	19.3 (0.491)	21.7 (0.550)	29.8 (0.757)	37.9 (0.963)

Ratings and Specifications

VHV5-F		VHV5-F□□□□023M-□□□	VHV5-F□□□□050M-□□□
Model		VHV5-F□□□□023M-□□□	VHV5-F□□□□050M-□□□
Image Sensor	Resolution	2.3 MP - 1920 (H) x 1200 (V)	5.0 MP - 2472 (H) x 2048 (V)
	Pixel Size	3 μm	2.74 μm
	Color / Monochrome	Monochrome CMOS	
	Shutter	Global Shutter	
	Frames per Second	80 FPS	40 FPS
	Exposure	16 μs to 300,000 μs	50 μs to 300,000 μs (16 μs to 300,000 μs with strobe duration)
	Lens Selections	Focal Length: Wide = 6.42 mm, Medium = 8.5 mm, Narrow = 12.5 mm, Long = 20 mm	
	Focus	Liquid Lens Autofocus	
Symbologies *1	1D Symbologies	Code 39, Code 128, BC412, Interleaved 2 of 5, UPC/EAN, Codabar, Code 93, Pharmacode, PLANET, POSTNET, Japanese Post, Australian Post, Royal Mail, Intelligent Mail, KIX	
	2D Symbologies	Data Matrix (ECC 0-200), QR Code, Micro QR Code, Aztec Code, DotCode	
	Stacked Symbologies	PDF417, MicroPDF417, GS1 Databar (Composite and Stacked)	
ISO Code Quality Checking	Data Matrix, QR Codes, 1D Symbologies	Models without Verification License: Code Quality Validation only using ISO 15416:2016, ISO 15415:2011, and ISO 29158:2020	
		Models with Verification License: Fully Calibrated ISO Code Quality Verification using ISO 15416:2016, ISO 15415:2011, and ISO 29158:2020	
Reading Performance *2	Number of Reading Digits	No upper limit (depends on bar width and reading distance)	
	Targeting Optics	Two green parallel LED spots	
	Illumination	8 high-power LEDs: White (6,500K) or Red (Wavelength: 625 nm)	
	Reading Distance / Field of View	Refer to "Distance, Field of View, and Readability Tables" earlier in this document for details based on Lens and Sensor Type.	
	Pitch Angle (α) *3	±30°	
	Skew Angle (β) *3	±30°	
	Tilt Angle (γ) *3	±180°	
Trigger		External Trigger (Edge or Level), Serial Trigger (Ethernet, RS-232C), PLC	
Digital I/O Specifications	Input Signals	3 Inputs: IN1 (Trigger), IN2 (Unused), IN3 (Unused). Bi-directional, Optoisolated, 4.5-28V-rated (10 mA @ 28 VDC).	
	Output Signals	3 Fully Configurable Outputs: OUT1, OUT2, OUT3. Bi-directional, Optoisolated, 3-28V rated, (I _{CE} < 100 mA @ 24 VDC, current limited by user).	
	External Strobe	24V, GND, Strobe+ (> 1.5kΩ, user-implemented), Strobe- (> 1.5kΩ, user-implemented), Analog Intensity Control (0-10V). (Strobe Trigger can operate as NPN or PNP).	
Communication	Connectivity	RS-232C, Ethernet TCP/IP, EtherNet/IP™, PROFINET	
	Ethernet Specifications	1000BASE-T	
Image Logging	Image Logging Type	To RAM	
Indicator LEDs	Membrane Switch	PWR (Green), LINK (Amber), MODE/STATUS (Amber), TRIGGER (Amber), PASS (Green), FAIL (Red)	
	360° Indicators	PASS (Green), FAIL (Red)	
Power Supply Voltage		Power over Ethernet (IEEE 802.3at) / 24 VDC +/- 10%	
Current Consumption		PoE+ 50-57 VDC @ 0.6 A (Max.); Direct: 24 VDC @ 2.1 A (Max.); External Light Port Connector: 24 VDC @ 1.5 A (Max) (Internally Current-Limited)	
Environmental / Immunity	Ambient Temperature Range	Operating: 0 to 45° C; Storage: -25 to 65° C (with no icing or condensation)	
	Ambient Humidity Range	Operating and Storage: 25% to 85%	
	Ambient Atmosphere	No Corrosive Gases	
	Vibration Resistance	Oscillation Frequency: 10 to 150 Hz; Half Amplitude: 0.35 mm; Vibration Direction: X/Y/Z; Sweep Time: 8 Minutes/Count; Sweep Count: 10 Times	
	Shock Resistance	Impact Force: 150 m/s ² , Test Direction: 6 Directions, 3 Times Each (Up / Down, Front / Behind, Left / Right)	
	Degree of Protection	IEC 60529 IP65, IEC 60529 IP67, ISO 20653 IP69K	
Weight	Main Body Only	372 g	
	Packaged Weight	505 g	
Dimensions	Main Body Dimensions	57.5 mm (W) × 50.5 mm (D) × 75 mm (H) (89 mm height with connectors)	
	Packaging Dimensions	170 mm (W) × 117 mm (D) × 86 mm (H)	
Accessories		ReadMeFirst, CE Compliance Sheet	
Safety Standards		IEC/EN 62368-1, 2nd and 3rd Ed; EN 62471 (LED Safety) UL 60950-1, 2nd Edition, 2019-05-09 (Information Technology Equipment - Safety - Part 1: General Requirements) CAN/CSA C22.2 No. 60950-1-07, 2nd Edition, 2014-10 (Information Technology Equipment - Safety - Part 1: General Requirements) *4	
Materials	Case	Aluminum, black anodized	
	Reading Window	Acrylic	
Software		WebLink	

*1. Symbologies are supported based on Omron's read capability validation standard. Omron recommends that validation be performed for each application.

*2. Unless otherwise specified, reading performance is defined with center of field of view, angle R = ∞.

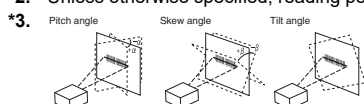

*4. FCC = United States
UL = United States
CE = European Union
UKCA = Great Britain (England / Wales / Scotland)
RCM = Australia / New Zealand
KC = South Korea

VHV5-F

Dimensions

VHV5-F Autofocus Multicode Reader

(Unit: mm)

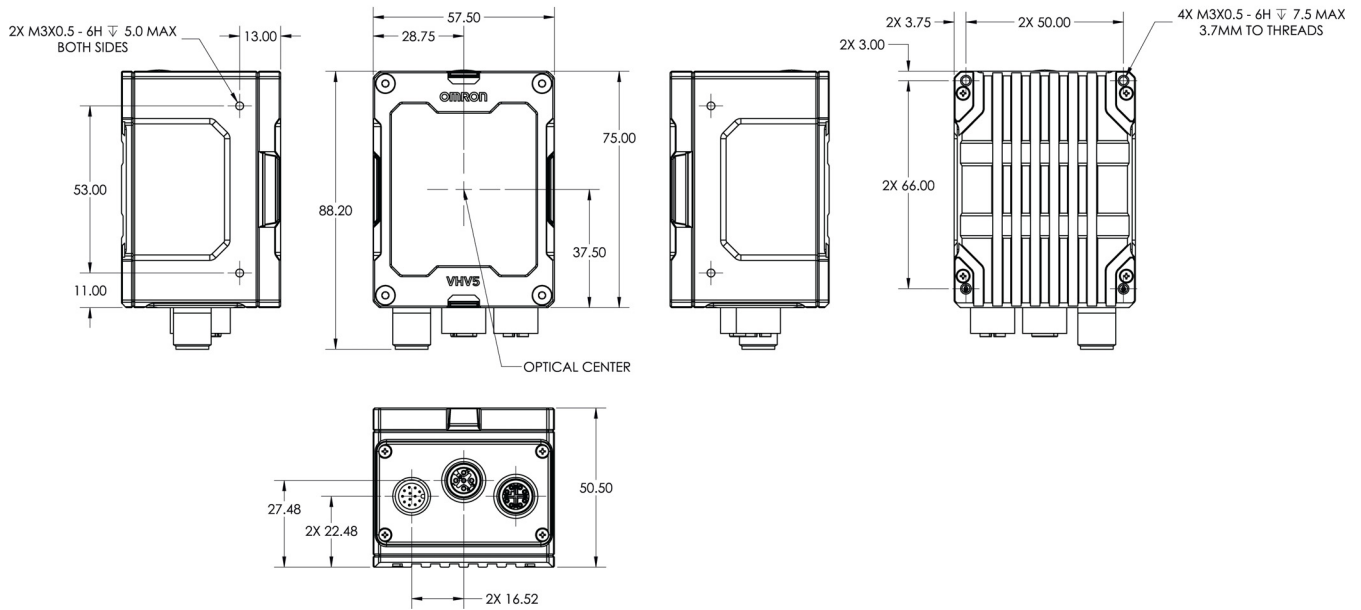
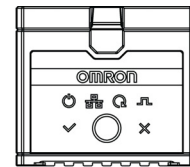

VHV5-F L-Bracket Adjustable Angle Mounting Kit
VHV5-AM0

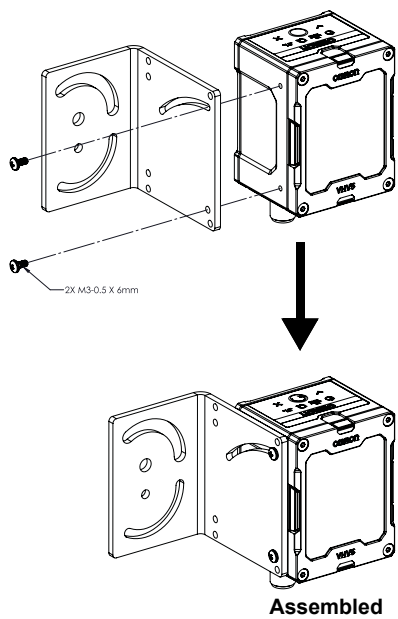
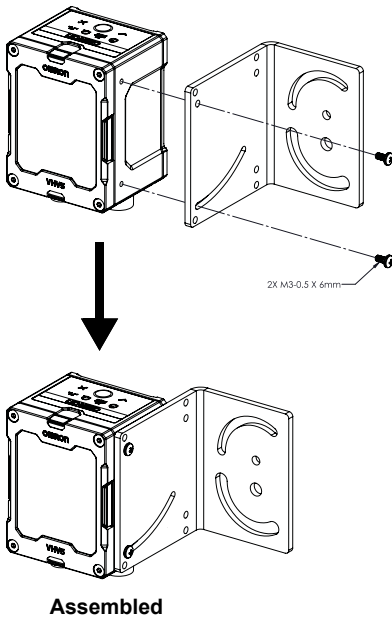
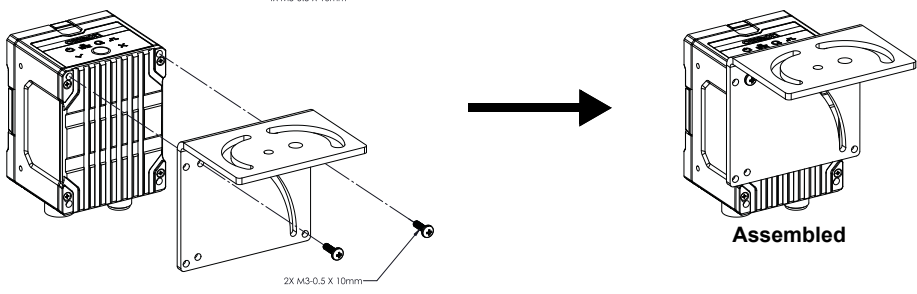
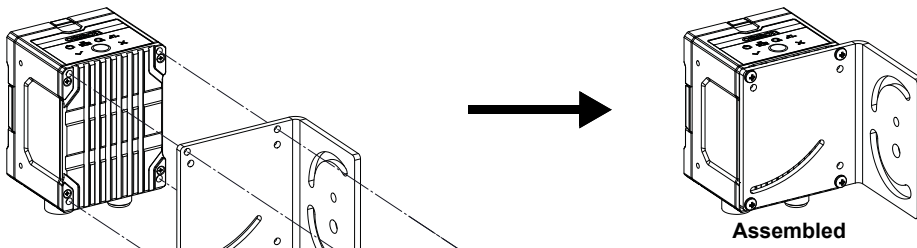
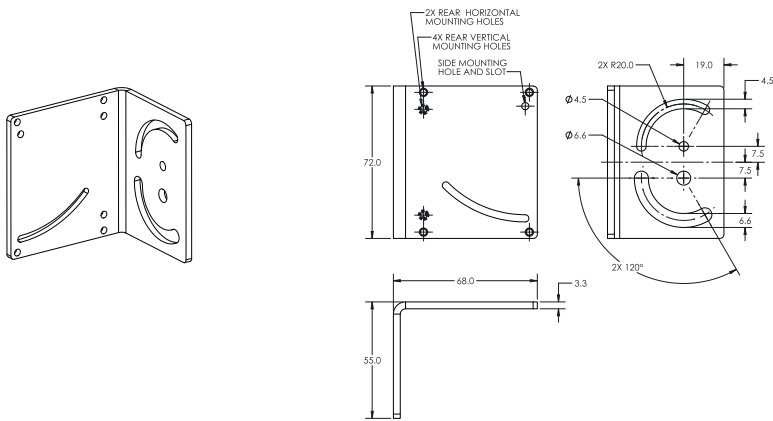

VHV5-F

VHV5-F Universal Mounting Block and Heatsink VHV5-AM1

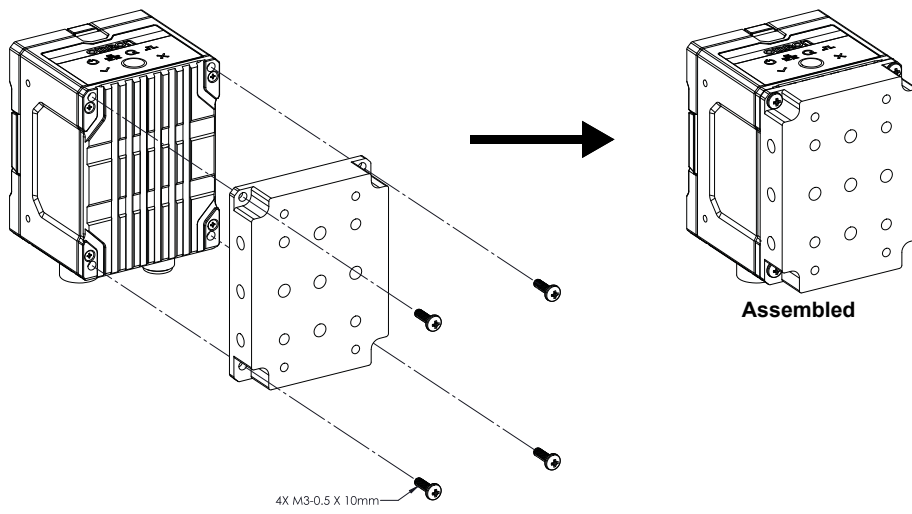
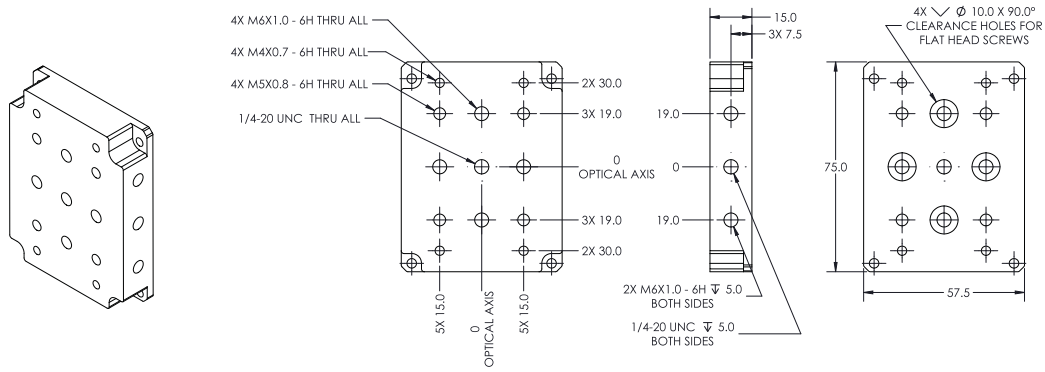

VHV5-F APG Pan and Tilt Camera Mount
VHV5-AM2

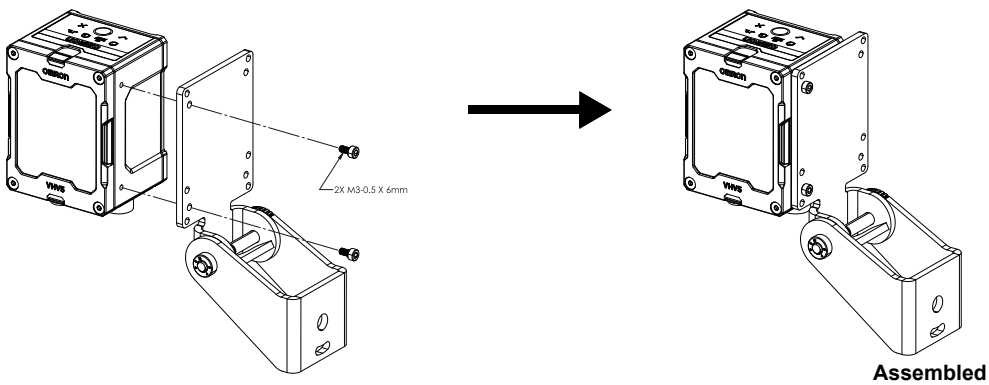
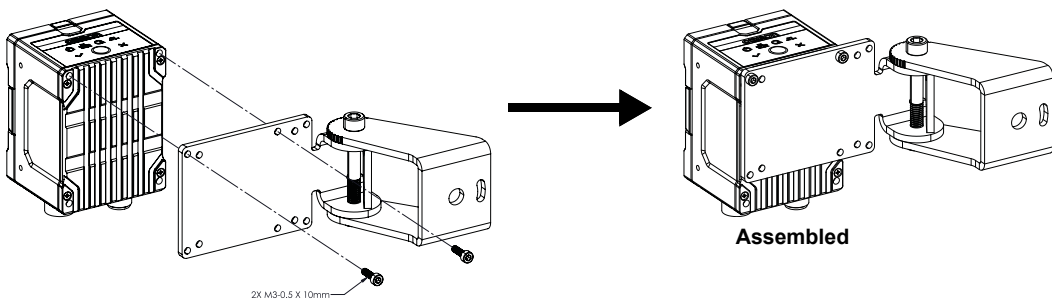
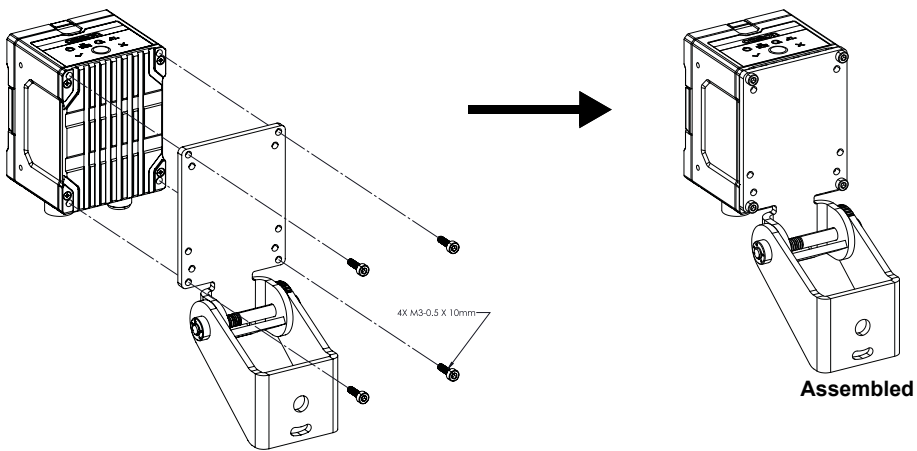
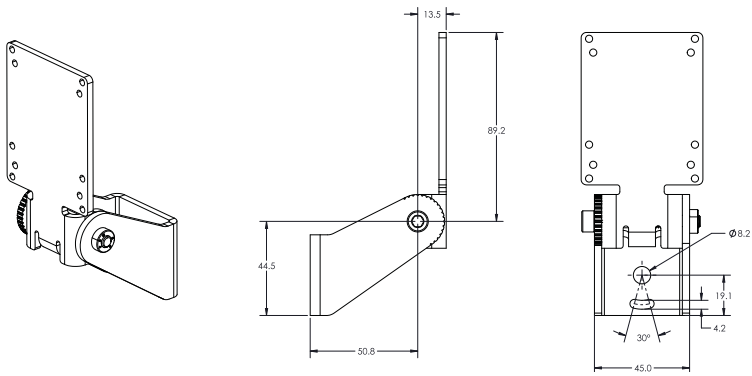

VHV5-F

VHV5-F Standard Window (for Wide and Medium Lens Models) VHV5-AF0

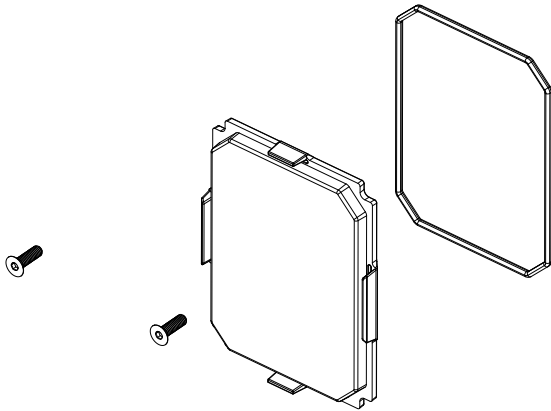

Torque: 4.8 in./lbs.
(0.54 nm max.)

VHV5-F Lensed Window (for Narrow and Long Lens Models) VHV5-AF1

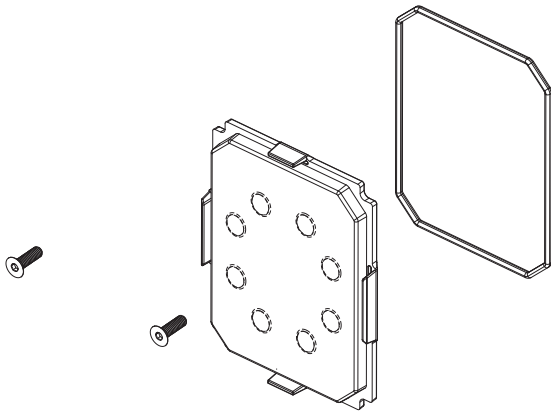

Torque: 4.8 in./lbs.
(0.54 nm max.)

VHV5-F Diffuser Accessory VHV5-AF2

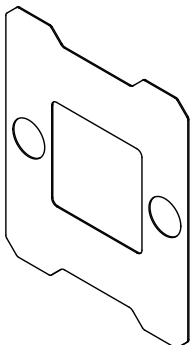

VHV5-F Polarizer Accessory
VHV5-AF3

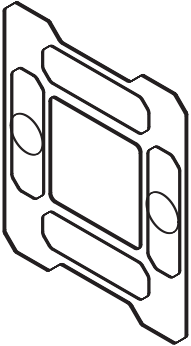

VHV5-F Half Polarizer Accessory
VHV5-AF4

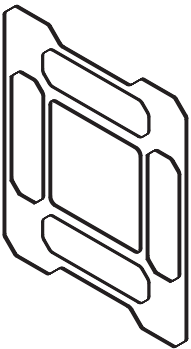

VHV5-F

X-Code to RJ45 Ethernet Cable (High Flex, Straight, Black Jacket) – 2 Meters, 3 Meters, 5 Meters, 10 Meters, 20 Meters

- FHV-VNB2 2M
- FHV-VNB2 3M
- FHV-VNB2 5M
- FHV-VNB2 10M
- FHV-VNB2 20M

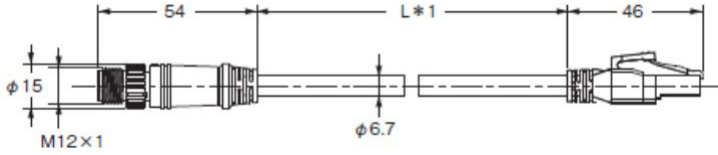

*1 – Overall cable length varies based on model number. Example: FHV-VNB2 2M is a 2 meter cable.

X-Code to RJ45 Ethernet Cable (High Flex, Right- Angle, Black Jacket) – 2 Meters, 3 Meters, 5 Meters, 10 Meters, 20 Meters

- FHV-VNLB2 2M
- FHV-VNLB2 3M
- FHV-VNLB2 5M
- FHV-VNLB2 10M
- FHV-VNLB2 20M

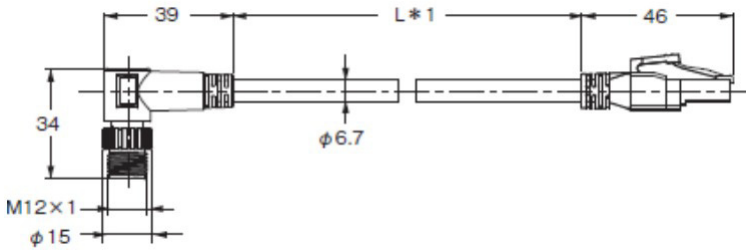

*1 – Overall cable length varies based on model number. Example: FHV-VNLB2 2M is a 2 meter cable.

M12 to Flying Leads Cable – Parallel IO (Power, DIO, RS-232) – 3 Meters, 5 Meters, 10 Meters

V430-W8-3M

V430-W8-5M

V430-W8-10M

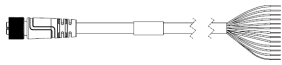

Pin	Name	Use
1	Trigger (Input 1)	Trigger
2	Power (+VIN)	24 Volts
3	Input 3	General Purpose Input
4	Input 2	General Purpose Input
5	Output 1	General Purpose Output
6	Output 3	General Purpose Output, Optional Light Control
7	Ground (-VIN)	24V Reference (GND)
8	Input Common	NPN or PNP Common for Input
9	RS-232 (Host) RxD	Serial Command Input
10	RS-232 (Host) TxD	Serial Output Data
11	Output 2	General Purpose Output
12	Output Common	NPN or PNP Common for Output

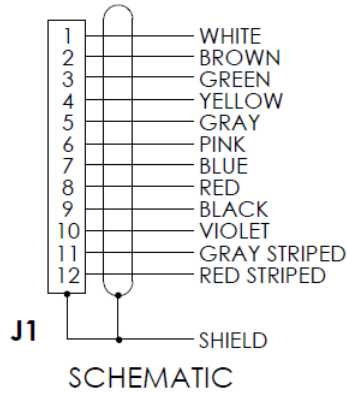

FEMALE END VIEW (J1)

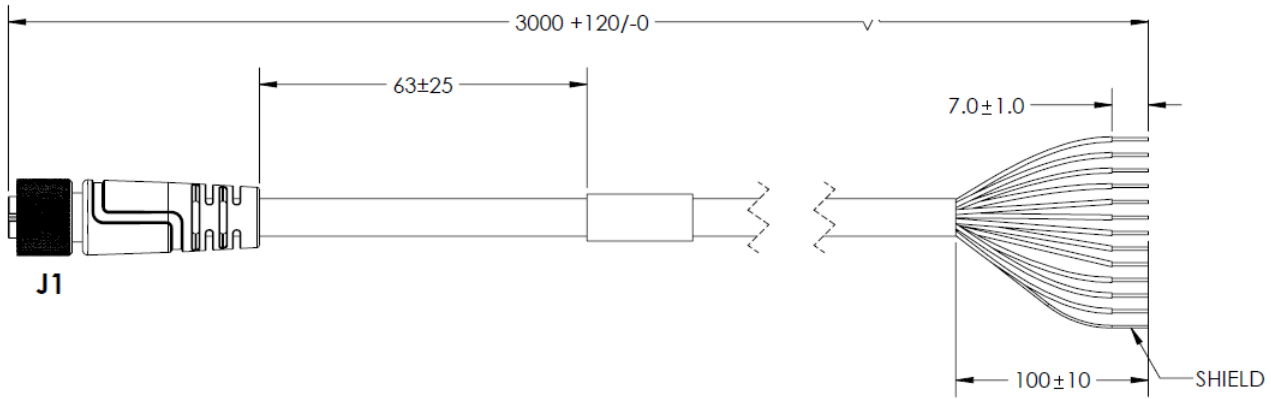
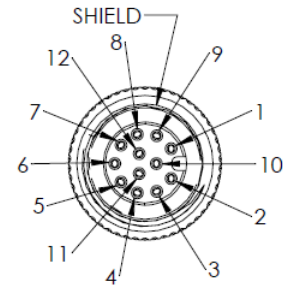

Pin	Name	Use
1	Trigger (Input 1)	Trigger
2	Power (+VIN)	24 Volts
3	Input 3	General Purpose Input
4	Input 2	General Purpose Input
5	Output 1	General Purpose Output
6	Output 3	General Purpose Output, Optional Light Control
7	Ground (-VIN)	24V Reference (GND)
8	Input Common	NPN or PNP Common for Input
9	RS-232 (Host) RxD	Serial Command Input
10	RS-232 (Host) TxD	Serial Output Data
11	Output 2	General Purpose Output
12	Output Common	NPN or PNP Common for Output

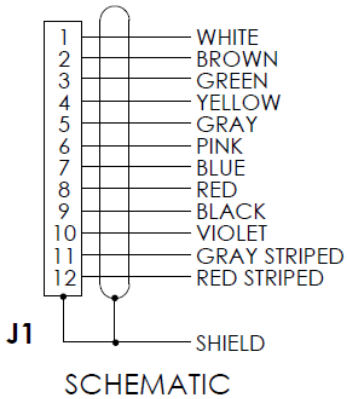

FEMALE END VIEW (J1)

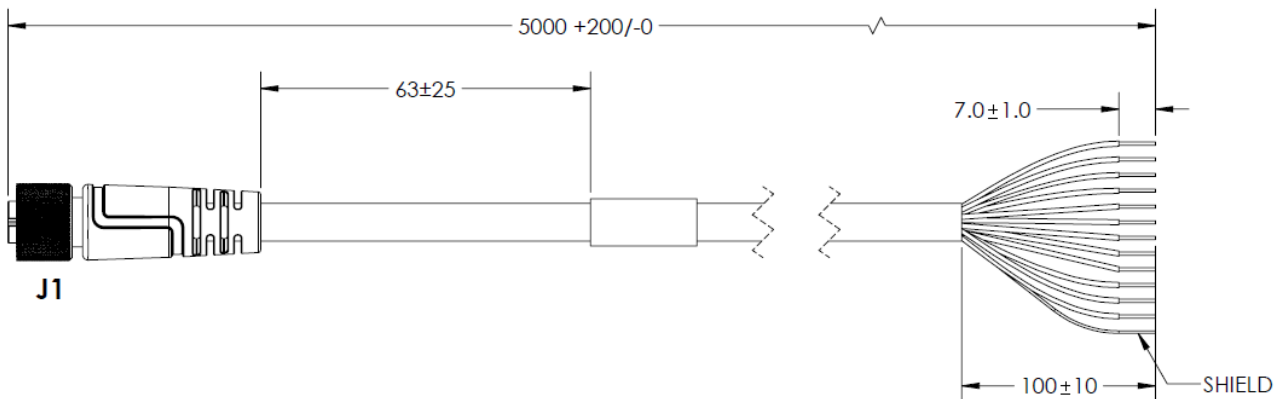
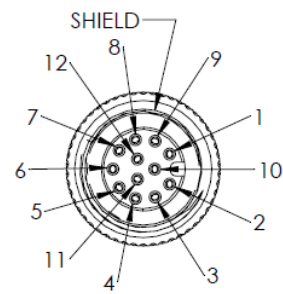

VHV5-F

M12 to Flying Leads Cable – Parallel IO (Power, DIO, RS-232), Right Angle Back – 3 Meters V430-W8LD-3M



Pin	Name	Use
1	Trigger (Input 1)	Trigger
2	Power (+VIN)	24 Volts
3	Input 3	General Purpose Input
4	Input 2	General Purpose Input
5	Output 1	General Purpose Output
6	Output 3	General Purpose Output, Optional Light Control
7	Ground (-VIN)	24V Reference (GND)
8	Input Common	NPN or PNP Common for Input
9	RS-232 (Host) RxD	Serial Command Input
10	RS-232 (Host) TxD	Serial Output Data
11	Output 2	General Purpose Output
12	Output Common	NPN or PNP Common for Output

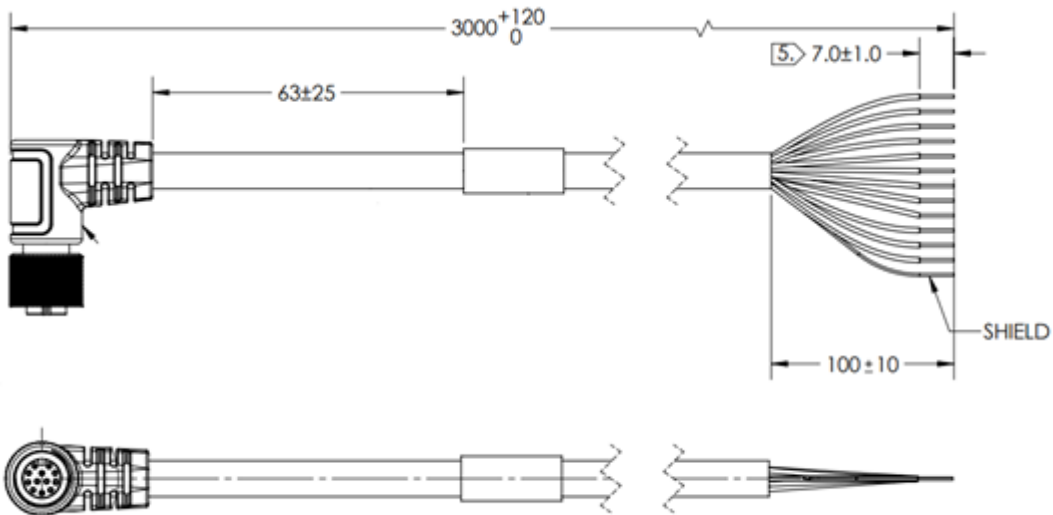
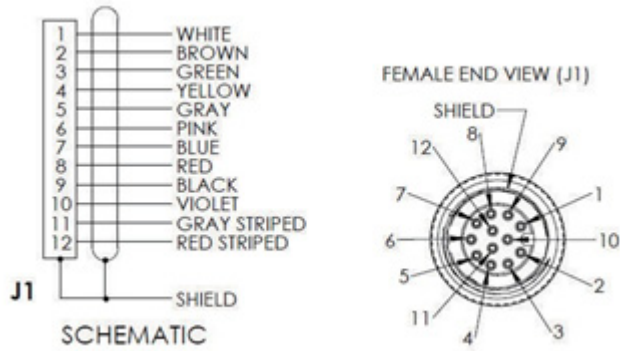

M12 to Flying Leads Cable – Parallel IO (Power, DIO, RS-232), Right Angle Front – 3 Meters
V430-W8LU-3M



Pin	Name	Use
1	Trigger (Input 1)	Trigger
2	Power (+VIN)	24 Volts
3	Input 3	General Purpose Input
4	Input 2	General Purpose Input
5	Output 1	General Purpose Output
6	Output 3	General Purpose Output, Optional Light Control
7	Ground (-VIN)	24V Reference (GND)
8	Input Common	NPN or PNP Common for Input
9	RS-232 (Host) RxD	Serial Command Input
10	RS-232 (Host) TxD	Serial Output Data
11	Output 2	General Purpose Output
12	Output Common	NPN or PNP Common for Output

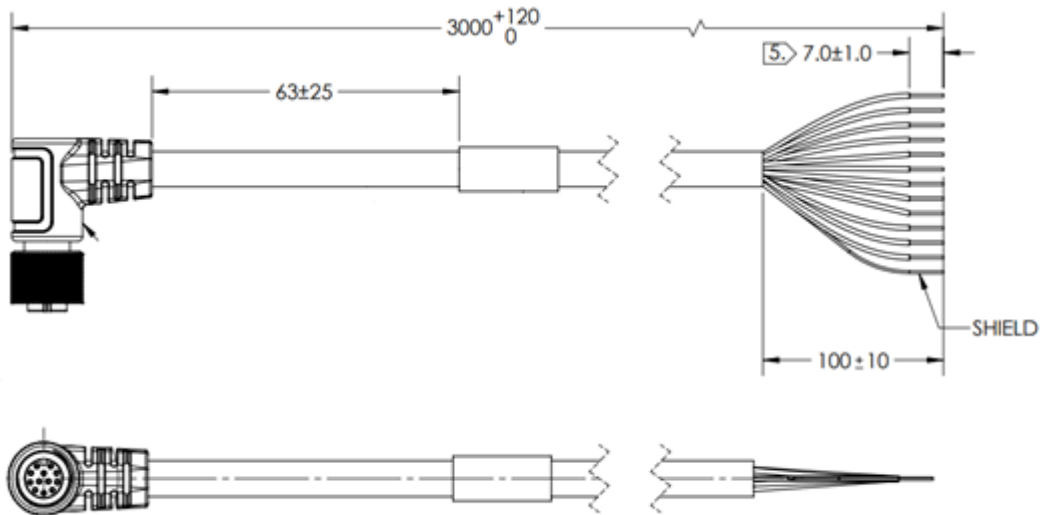
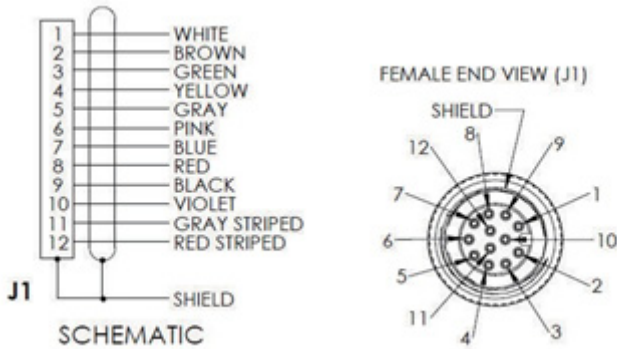

VHV5-F

Reader M12 to RS-232 Breakout Cable – 1 Meter, 3 Meters
 V430-WR-1M
 V430-WR-3M

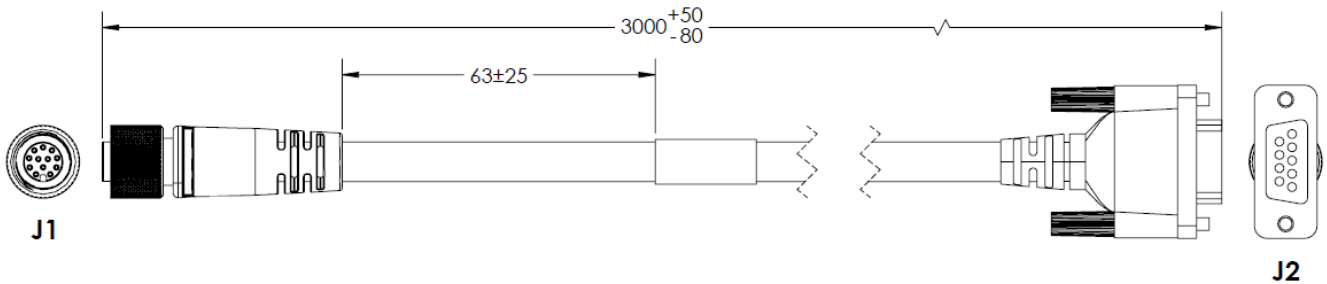
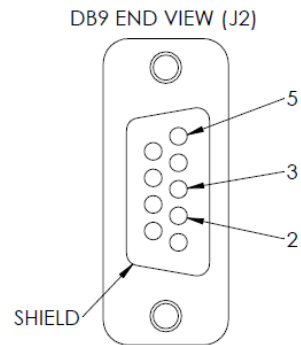
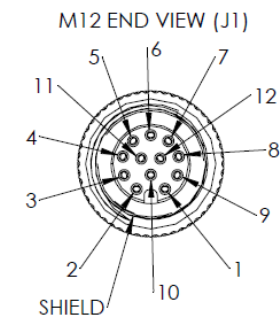
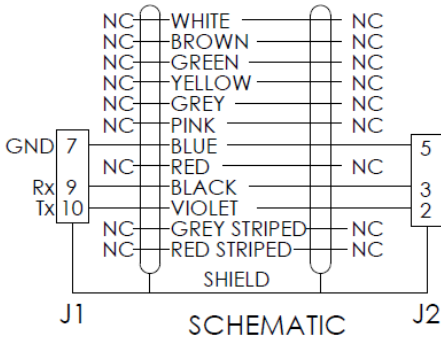
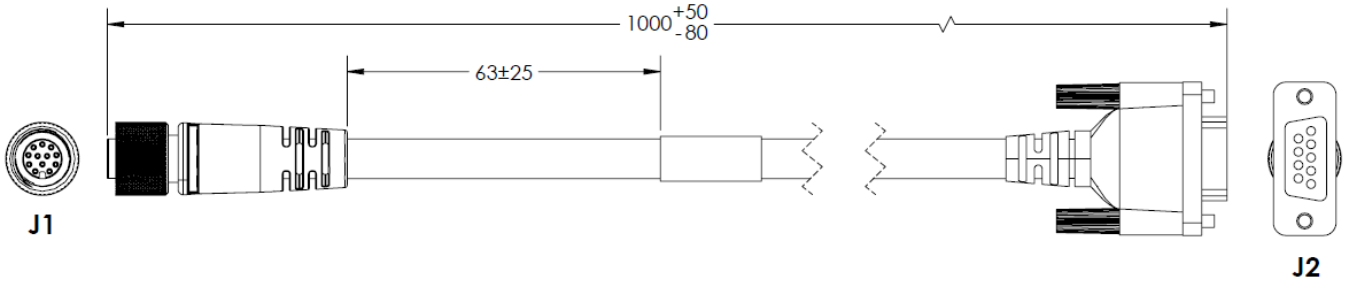
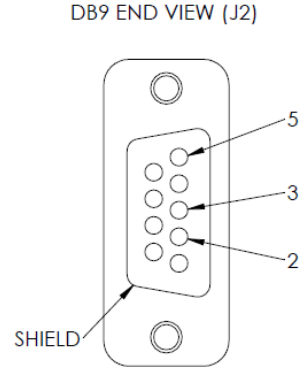
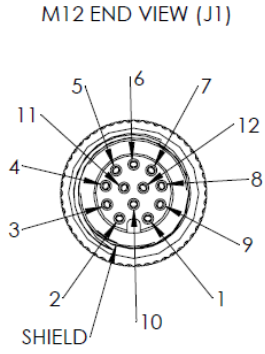
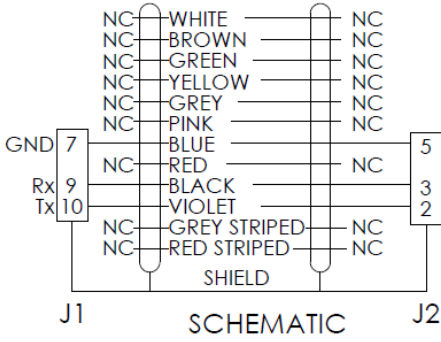

VHV5-F to External Light – 5 Pin M12 Plug to 5 Pin M12 Socket – 1 Meter
 61-000184-01

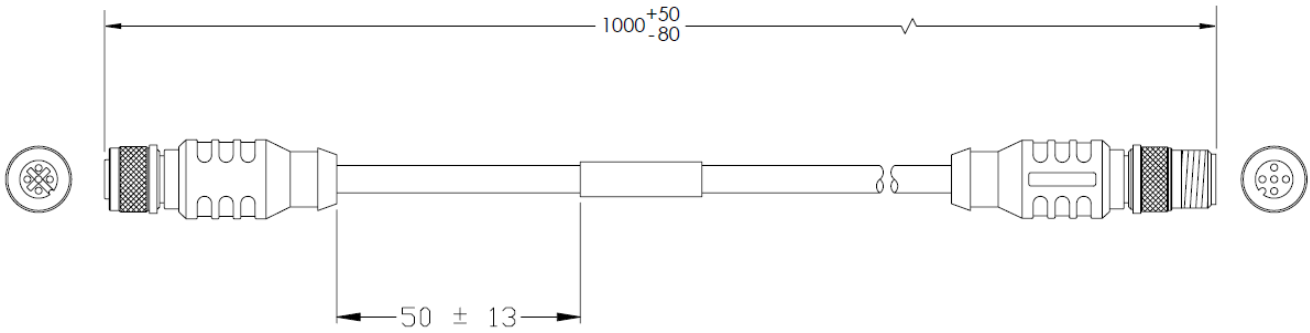

FEMALE END VIEW	MALE END VIEW
<p>1 = BROWN 2 = WHITE 3 = BLUE 4 = BLACK 5 = GRAY</p>	<p>1 = BROWN 2 = WHITE 3 = BLUE 4 = BLACK 5 = GRAY</p>

VHV5-F

Cable, Adapter, Omron PLC – 2 Meters V430-WPLC-2M

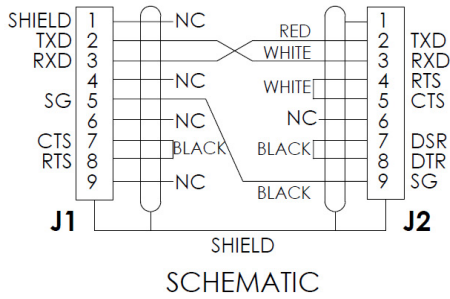
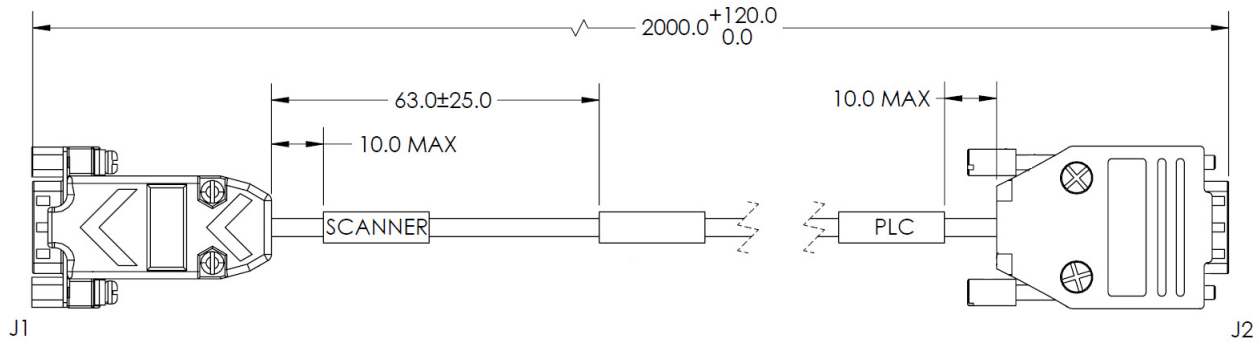

9 POS D-SUB PLUG (J1)

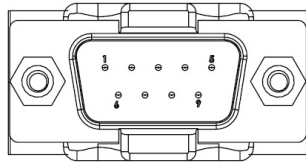

9 POS D-SUB PLUG (J2)

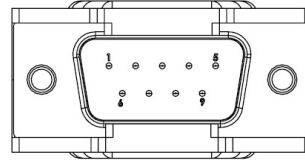

SHIELD SCHEMATIC

Power Supply, 100-240VAC, +24VDC, M12 12-Pin Socket – 1 Meter – U.S. / Euro Plug
97-000012-01

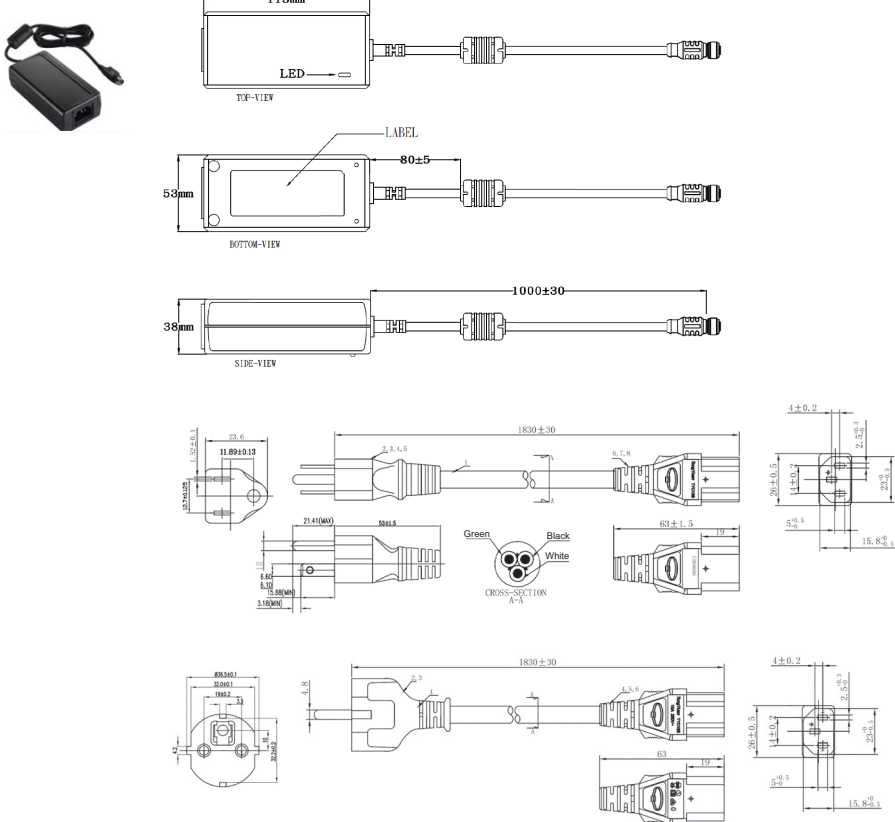

Single Port PoE Injector, 30W, IEEE802.3at Compliant, 2 x RJ45 Connector, 90 to 264VAC
98-9000311-01

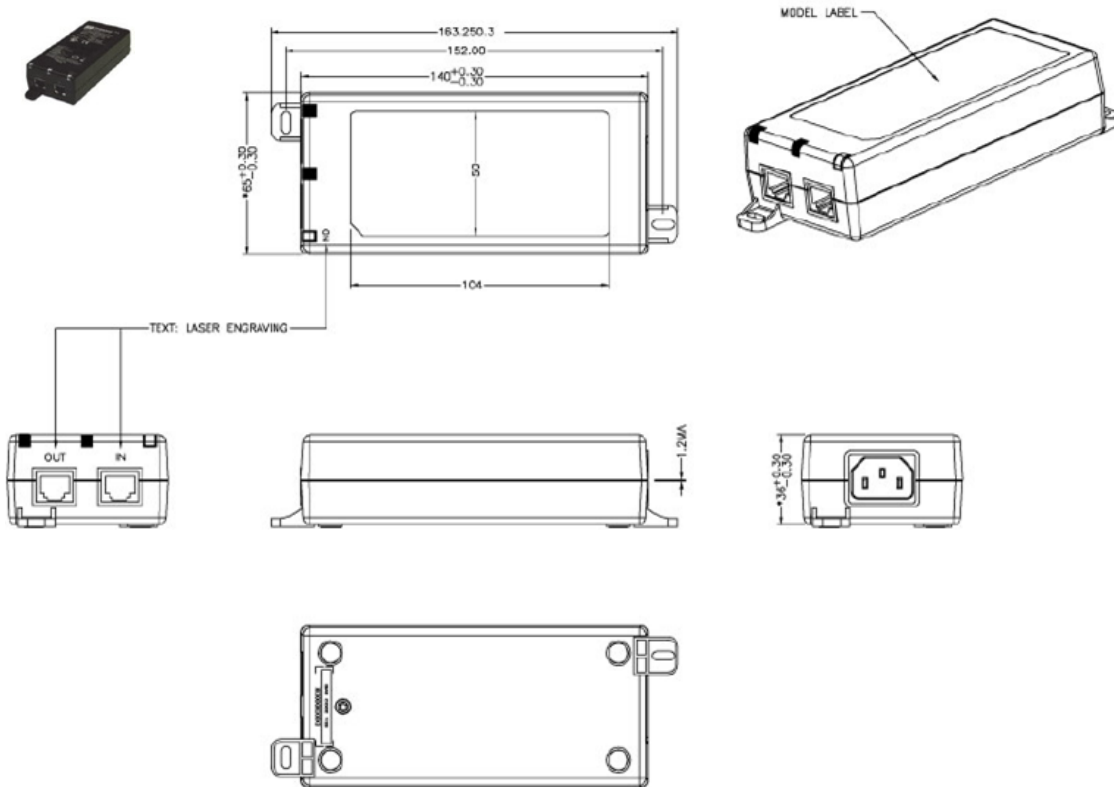

VHV5-F

Reader Interconnect Cable – M12 Socket to M12 Plug – 1 Meter, 3 Meters, 5 Meters

V430-WQ-1M

V430-WQ-3M

V430-WQ-5M

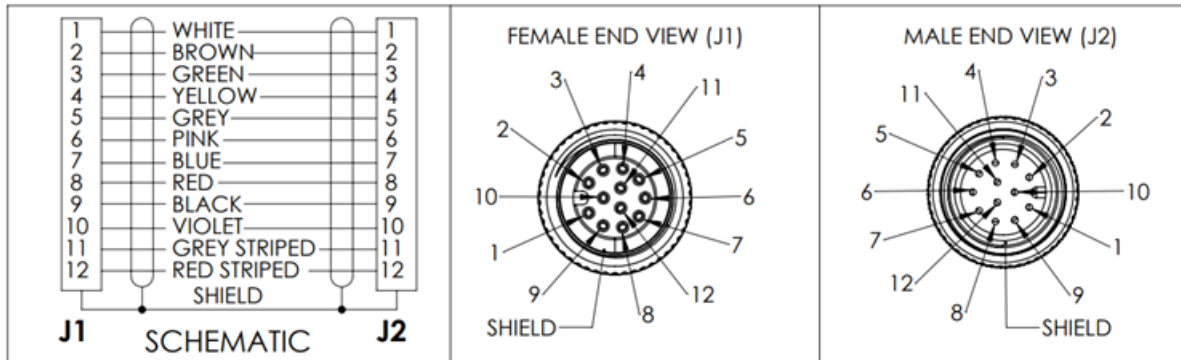
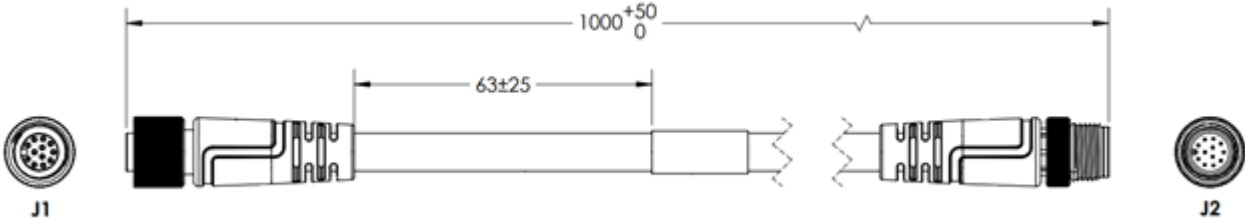

VHV5-F Interconnect Cables with RS-232 Breakout – 3 Meters, 5 Meters
 V430-WQR-3M
 V430-WQR-5M

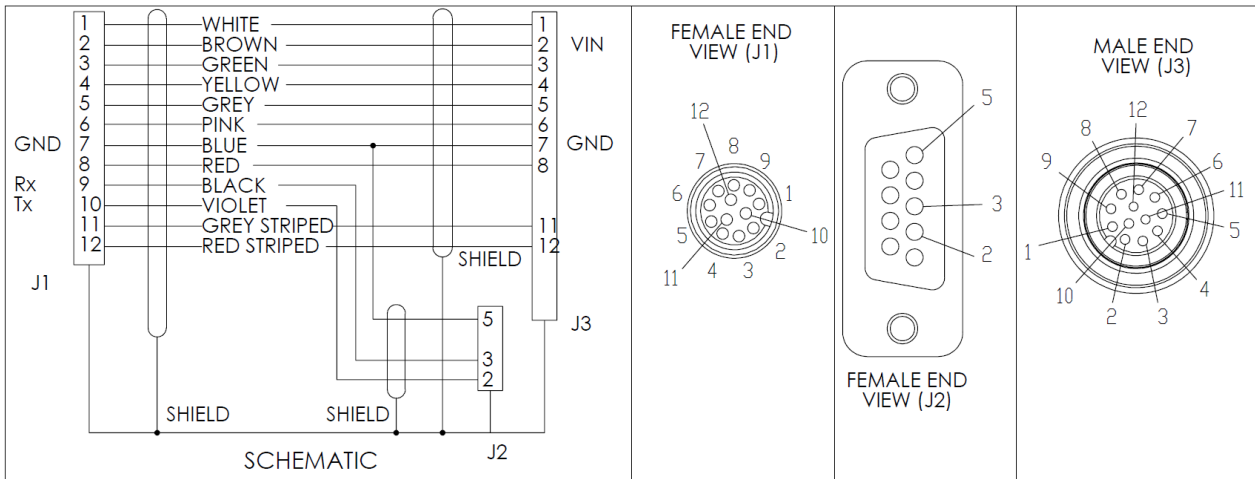
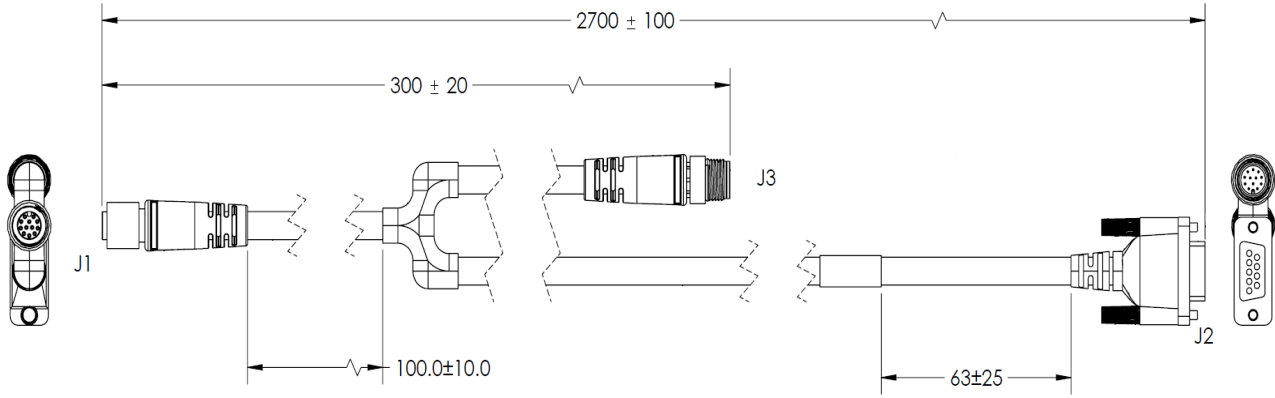
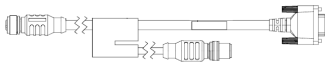

Related Manuals

Model	Part Number	Manual
VHV5-F	Z476 (84-9000470-02)	VHV5-F Autofocus Multicode Reader User Manual
	Z477 (84-9350057-02)	VHV5-F Autofocus Multicode Reader Communication Manual

OMRON AUTOMATION AMERICAS HEADQUARTERS • Chicago, IL USA • 847.843.7900 • 800.556.6766 • automation.omron.com

OMRON CANADA, INC. • HEAD OFFICE

Montreal, Quebec, Canada • 416.286.6465 • 866.986.6766 • automation.omron.com

OMRON MÉXICO • HEAD OFFICE

Mexico City, Mexico • 55 5901 4300 - mela@omron.com

OMRON MÉXICO • GUADALAJARA

Guadalajara, Jal, Mexico • 55.5901.4300

OMRON ELETRÔNICA DO BRASIL LTDA • HEAD OFFICE

São Paulo, SP, Brasil • 55 11 5171-8920 • automation.omron.com

OTHER OMRON LATIN AMERICA SALES

+54.11.4521.8630 • +54.11.4523.8483 • mela@omron.com

Controllers & I/O

- Machine Automation Controllers (MAC) • Motion Controllers
- Programmable Logic Controllers (PLC) • Temperature Controllers • Remote I/O

Operator Interfaces

- Human Machine Interface (HMI)

Motion & Drives

- Machine Automation Controllers (MAC) • Motion Controllers • Servo Systems
- Frequency Inverters

Identification and Vision

- Vision Sensors & Systems • Measurement Sensors • Auto Identification Systems

Sensing

- Photoelectric Sensors • Fiber-Optic Sensors • Proximity Sensors
- Rotary Encoders • Ultrasonic Sensors

Safety

- Safety Light Curtains • Safety Laser Scanners • Programmable Safety Systems
- Safety Mats and Edges • Safety Door Switches • Emergency Stop Devices
- Safety Switches & Operator Controls • Safety Monitoring/Force-guided Relays

Control Components

- Power Supplies • Timers • Counters • Programmable Relays
- Digital Panel Meters • Monitoring Products

Switches & Relays

- Limit Switches • Pushbutton Switches • Electromechanical Relays
- Solid State Relays

Software

- Programming & Configuration • Runtime